Engineering Analysis

Syllabus

- 1- Introduction.
- 2- First Order Ordinary Differential Equations.
- 3- Applications on First Order Ordinary Differential Equations.
- 4- Second and Higher Order Ordinary Differential Equations.
- 5- Applications on Second and Higher Order Ordinary Differential Equations.
- 6- Simultaneous Linear Ordinary Differential Equations.

References

- Advanced Engineering Mathematics,
by C. R. Wylie.

- Advanced Engineering Mathematics,
by E. Kreyszig.

- Advanced Engineering Mathematics,
by O'Neil.

- Advanced Mathematics for Engineers and Scientists,
by M. R. Spiegel.

- Differential Equations,
by F. Ayres.

1- Introduction

Definition of differential equations

A differential equation is an equation that contains one or more derivatives, such as

$$\frac{dy}{dx} + \frac{d^2y}{dx^2} = \cos x, \quad Dz + D^4z + z = 0, \quad y'' + y' - \ln x = 0 \quad \text{and} \quad \dot{x} - 2\ddot{x} = 5$$

Classification of differential equations

A) By type:

* *Ordinary differential equation* (ODE): in which all derivatives are with respect to a single independent variable, such as

$$\frac{dy}{dx} + \ln x = x, \quad dy + xdx = 0, \quad \text{and} \quad \frac{dy}{dx} + \frac{dz}{dx} = 0.$$

* *Partial differential equation* (PDE): in which at least one derivative is with respect to two or more independent variables, such as

$$\frac{\partial^2 u}{\partial x^2} + \frac{\partial u}{\partial y} = x \quad \text{and} \quad \frac{\partial w}{\partial x} = \frac{\partial u}{\partial x} + \frac{\partial u}{\partial y}.$$

B) By order:

The order of the differential equation is the order of the highest derivative appears in that equation, for example

$$\left(\frac{dy}{dx}\right)^2 + \sin x = 0 \text{ is a first-order ordinary differential equation (1st order ODE).}$$

$$\frac{\partial^3 u}{\partial x^3} + \frac{\partial u}{\partial y} = 0 \text{ is a third-order partial differential equation (3rd order PDE).}$$

C) By degree:

The degree of the differential equation is the power of the highest derivative appears in that equation, for example

$$\left(\frac{dy}{dx}\right)^2 + \sin x = 0 \quad \text{is a 2nd degree, 1st order ODE.}$$

$$y'' + y' - y^2 = e^x \quad \text{is a 1st degree, 2nd order ODE.}$$

$$(y''')^2 + 2(y')^4 = 2x \quad \text{is a 2nd degree, 3rd order ODE.}$$

D) By linearity:

A differential equation is said to be "linear DE" if and only if each term of the equation which contains a dependent variable and/or its derivative is of linear form. In another words a differential equation is said to be "linear DE" if:

- 1- The dependent variable and all its derivatives appear in a linear form.
- 2- There is no production of a dependent variable with one of its derivatives, or one of its derivatives with another derivative.

For example

$$y''' + 2y' + y = x^2 \quad \text{is a linear 1st degree, 3rd order ODE.}$$

$$\frac{dy}{dx} + y^2 = 1 \quad \text{is a non-linear 1st degree, 1st order ODE.}$$

$$\frac{d^2y}{dx^2} + \sin y = 0 \quad \text{is a non-linear 1st degree, 2nd order ODE.}$$

$$y^{iv} + (y')^2 = x \quad \text{is a non-linear 1st degree, 4th order ODE.}$$

$$\frac{\partial^3 u}{\partial x^3} = u \cdot \frac{\partial u}{\partial y} \quad \text{is a non-linear 1st degree, 3rd order PDE.}$$

$$\frac{d^4y}{dx^4} + \frac{d^2y}{dx^2} \cdot \frac{dy}{dx} = 0 \quad \text{is a non-linear 1st degree, 4th order ODE.}$$

Solution of differential equations

The solution of a DE is a relation between the variables which is free of derivatives and satisfies that DE identically.

* *General solution*: The general solution of the n^{th} order DE is a relation between the variables involving n independent arbitrary constants which satisfy the DE.

For example, for the DE $\frac{d^3 y}{dx^3} = 0$, $y_1 = A$ is a solution to the above DE., $y_2 = Bx$ is also

a solution, and $y_3 = Cx^2$ is also a solution.

$$\therefore y = y_1 + y_2 + y_3 = A + Bx + Cx^2 \quad \text{is a general solution (G.S).}$$

* *Particular solution*: The particular solution of a DE is one obtained from the general solution of that DE by assigning specific values to the arbitrary constants. For

example, for the DE $\frac{d^2 y}{dx^2} = 0$, $y = A + Bx$ is a general solution (G.S) to the above

DE. Then $y = 2 + 3x$ is a particular solution (P.S) to the above DE.

Note: If $\frac{dy}{dx} = x \Rightarrow dy = x.dx$ (variables are separated),

$$\text{then, to solve it } \int dy = \int x.dx \Rightarrow y = \frac{x^2}{2} + C.$$

If $\frac{dy}{dx} = x + y \Rightarrow dy = (x + y).dx$ (variables are not separated),

then we must find a proper way to solve it.

Origin of differential equations

* *Geometric problems*. For example

If we want to find the family of curves which have a value equal to its slope

then we must solve the DE $y = \frac{dy}{dx}$.

* *Physical problems*. For example

$$\sum F = m \cdot \frac{d^2 x}{dt^2} \quad (\text{Newton's 2}^{\text{nd}} \text{ law}) \quad \text{and} \quad EI \cdot y'' = -M \quad (\text{Flexural equation})$$

2- First-Order Ordinary Differential Equations

Introduction

A differential equation of the first order and first degree may be written in one of the following two forms

1- $\frac{dy}{dx} = f(x, y)$ (The slope form)

2- $M(x, y)dx + N(x, y)dy = 0$ (The exact form)

For example, the following DE

$$\frac{dy}{dx} = \frac{2x - y}{y - 3x} \quad \text{may be rewritten as} \quad (2x - y)dx - (y - 3x)dy = 0,$$

where, $f(x, y) = \frac{2x - y}{y - 3x}$, $M(x, y) = 2x - y$, and $N(x, y) = -(y - 3x)$.

1- Separable variables differential equations

If we can separate the dependent variable and its differential from the independent variable and its differential in a DE, then this DE is called "separable variables DE". For example, if a given first-order DE can be reduced to

$$\frac{dy}{dx} = f(x, y) \quad \Rightarrow \quad \frac{dy}{dx} = g(x).h(y) \quad \Rightarrow \quad \frac{1}{h(y)}.dy = g(x).dx.$$

Or $M(x, y)dx + N(x, y)dy = 0 \quad \Rightarrow \quad g_1(x).h_1(y).dx + g_2(x).h_2(y).dy = 0,$

$$\Rightarrow \quad \frac{g_1(x)}{g_2(x)}.dx + \frac{h_1(y)}{h_2(y)}.dy = 0,$$

then such equation is called "separable variables DE" which can be solved by integrating both sides.

Example 1: Solve the following first-order differential equation $\frac{dy}{dx} = \frac{-x}{y}$.

Solution :

$$\frac{dy}{dx} = \frac{-x}{y} \quad (\text{separable variables DE}) \quad \Rightarrow \quad y.dy = -x.dx,$$

$$\therefore \int y.dy = \int -x dx \quad \Rightarrow \quad \frac{y^2}{2} = \frac{-x^2}{2} + C_1,$$

or $y^2 = -x^2 + 2C_1 \quad \Rightarrow \quad y^2 + x^2 = 2C_1$

$$\therefore y^2 + x^2 = C. \quad [C = 2C_1] \quad (\text{General solution G.S})$$

Notes:

* The previous DE may be given in different forms, like

$$y' = \frac{-x}{y} \quad \text{or} \quad Dy = \frac{-x}{y} \quad \text{or} \quad y.dy + x.dx = 0.$$

* As a check, we try to find dy/dx by differentiating the general solution,

$$y^2 + x^2 = C \quad \Rightarrow \quad 2y.dy + 2x dx = 0 \quad \Rightarrow \quad \frac{dy}{dx} = \frac{-x}{y}. \quad \text{O.K}$$

$$\text{Or} \quad 2y \frac{dy}{dx} + 2x = 0 \quad \Rightarrow \quad \frac{dy}{dx} = \frac{-x}{y}.$$

Example 2: Solve $(1 + x^3).dy - x^2 y.dx = 0$.

Solution:

$$(1 + x^3).dy - x^2 y.dx = 0 \quad (\text{separable variables DE}) \quad \Rightarrow \quad \frac{dy}{y} - \frac{x^2}{1 + x^3}.dx = 0,$$

$$\therefore \int \frac{dy}{y} - \int \frac{x^2}{1 + x^3}.dx = \int 0 \quad \Rightarrow \quad \ln y - \frac{1}{3} \ln(1 + x^3) = C_1,$$

or $3 \ln y - \ln(1 + x^3) = 3C_1 \quad \Rightarrow \quad \ln y^3 - \ln(1 + x^3) = C_2, \quad [C_2 = 3C_1]$

$$\Rightarrow \quad \ln \frac{y^3}{1 + x^3} = C_2 \quad \Rightarrow \quad \frac{y^3}{1 + x^3} = e^{C_2} \quad \Rightarrow \quad \frac{y^3}{1 + x^3} = C \quad [C = e^{C_2}]$$

$$\therefore y^3 = C(1 + x^3). \quad (\text{G.S})$$

Example 3: Solve $y' = xy - x$, $y(0) = 3$.

Solution:

$$\frac{dy}{dx} = xy - x \Rightarrow \frac{dy}{dx} = x(y - 1) \quad (\text{separable variables DE})$$

$$\therefore \frac{dy}{y-1} = x dx \Rightarrow \int \frac{dy}{y-1} = \int x dx \Rightarrow \ln(y-1) = \frac{x^2}{2} + C_1,$$

$$\text{or } y-1 = e^{\frac{x^2}{2} + C_1} \Rightarrow y-1 = e^{\frac{x^2}{2}} \cdot e^{C_1} \Rightarrow y-1 = Ce^{\frac{x^2}{2}}, \quad [C = e^{C_1}]$$

$$\therefore y = 1 + Ce^{\frac{x^2}{2}}. \quad (\text{G.S})$$

$$\text{Apply the given condition, at } x=0, \quad y=3 \Rightarrow 3 = 1 + Ce^{0^2/2} \Rightarrow C = 2.$$

$$\therefore y = 1 + 2e^{\frac{x^2}{2}}. \quad (\text{P.S})$$

Example 4: Solve $\frac{dy}{dx} = -2 + e^{2x+y-1}$.

Solution:

$$\text{Let } z = 2x + y - 1 \Rightarrow dz = 2dx + dy \Rightarrow \frac{dy}{dx} = \frac{dz}{dx} - 2,$$

$$\therefore \frac{dz}{dx} - 2 = -2 + e^z \Rightarrow \frac{dz}{dx} = e^z, \quad (\text{separable variables DE})$$

$$\frac{dz}{e^z} = dx \Rightarrow \int \frac{dz}{e^z} = \int dx \Rightarrow -e^{-z} = x + C_1,$$

$$\text{or } x + e^{-z} = -C_1 \Rightarrow x + e^{-2x-y+1} = C. \quad [C = -C_1] \quad (\text{G.S})$$

Example 5: Solve $x(2xy + 1)dy + y(1 + 2xy - x^3y^3)dx = 0$.

Solution:

$$\text{Let } z = xy \Rightarrow dz = xdy + ydx \Rightarrow dy = \frac{dz - ydx}{x} \Rightarrow dy = \frac{dz - \frac{z}{x}dx}{x},$$

$$\therefore x(2z + 1) \frac{dz - \frac{z}{x}dx}{x} + \frac{z}{x}(1 + 2z - z^3)dx = 0 \Rightarrow (2z + 1).dz - \frac{z^4}{x}.dx = 0, \quad (\text{separable})$$

$$\frac{2z+1}{z^4} \cdot dz - \frac{dx}{x} = 0 \Rightarrow \int \frac{2z+1}{z^4} \cdot dz - \int \frac{dx}{x} = \int 0 \Rightarrow \int \left(\frac{2}{z^3} + \frac{1}{z^4} \right) \cdot dz - \int \frac{dx}{x} = \int 0,$$

$$-\frac{1}{z^2} - \frac{1}{3z^3} - \ln x = C_1 \Rightarrow \frac{1}{(xy)^2} + \frac{1}{3(xy)^3} + \ln x = C. \quad [C = -C_1] \quad (\text{G.S})$$

2- Homogeneous differential equations (reducible to separable DE)

A function $f(x, y)$ is said to be homogeneous of degree n if;

$$f(tx, ty) = t^n f(x, y).$$

For example,

* If $f(x, y) = 2y^4 - x^2 y^2$, then

$$f(tx, ty) = 2(ty)^4 - (tx)^2 (ty)^2 = t^4 (2y^4 - x^2 y^2) = t^4 f(x, y),$$

$\therefore f(x, y)$ is homogeneous of degree 4.

* If $f(x, y) = \frac{y}{x} - 3e^{x/y} + \sin \frac{x}{y}$, then

$$f(tx, ty) = \frac{ty}{tx} - 3e^{tx/ty} + \sin \frac{tx}{ty} = t^0 \left(\frac{y}{x} - 3e^{x/y} + \sin \frac{x}{y} \right) = t^0 f(x, y),$$

$\therefore f(x, y)$ is homogeneous of degree 0.

The differential equation $M(x, y)dx + N(x, y)dy = 0$ is called homogeneous if $M(x, y)$ and $N(x, y)$ are homogeneous and of the same degree (i.e. all terms of the DE are of the same total degree in the variables x and y).

For example,

* $x(y+x)dx = y^2 dy$, is homogeneous of degree 2.

* $(xy+x)dx = (y^2 - x^2)dy$, is non-homogeneous.

* $y(\ln y - \ln x - 1)dx + xdy = 0$, is homogeneous of degree 1.

* $y(\ln y - 1)dx + xdy = 0$, is non-homogeneous.

The homogeneous DE can be always reduced to separable variables DE by the substitution $y = ux$ or $x = uy$.

Example 1: Solve $2(2x^2 + y^2)dx - xydy = 0$.

Solution :

The given DE is homogeneous of degree 2.

$$\text{Let } y = ux \Rightarrow dy = udx + xdu,$$

$$\therefore 2(2x^2 + (ux)^2)dx - x(ux)(udx + xdu) = 0$$

$$\Rightarrow (4x^2 + 2u^2x^2)dx - u^2x^2dx - ux^3du = 0,$$

$$\Rightarrow (4x^2 + u^2x^2)dx - ux^3du = 0 \Rightarrow (4 + u^2)dx - uxdu = 0, \quad (\text{Separable DE})$$

$$\frac{dx}{x} - \frac{u}{4 + u^2} du = 0 \Rightarrow \ln x - \frac{1}{2} \ln(4 + u^2) = C_1,$$

$$\text{or } 2 \ln x - \ln(4 + u^2) = 2C_1 \Rightarrow \ln \frac{x^2}{4 + u^2} = 2C_1 \Rightarrow \frac{x^2}{4 + u^2} = e^{2C_1},$$

$$\Rightarrow \frac{x^2}{4 + u^2} = C \quad [C = e^{2C_1}] \Rightarrow x^2 = C(4 + u^2) \Rightarrow x^2 = C\left(4 + \left(\frac{y}{x}\right)^2\right),$$

$$\therefore x^4 = C(4x^2 + y^2). \quad (\text{G.S})$$

Note:

* The given DE can also be solved by letting $x = uy$.

Example 2: Solve $ydx + \left[y \cos^2\left(\frac{x}{y}\right) - x \right] dy = 0$.

Solution :

The given DE is homogeneous of degree 1.

$$\text{Let } x = uy \Rightarrow dx = udy + ydu,$$

$$\therefore y(udy + ydu) + \left[y \cos^2\left(\frac{uy}{y}\right) - uy \right] dy = 0 \Rightarrow yudy + y^2du + y \cos^2 u dy - uydy = 0,$$

$$\Rightarrow y^2du + y \cos^2 u dy = 0 \Rightarrow ydu + \cos^2 u dy = 0, \quad (\text{Separable DE})$$

$$\frac{du}{\cos^2 u} + \frac{dy}{y} = 0 \Rightarrow \sec^2 u du + \frac{dy}{y} = 0 \Rightarrow \tan u + \ln y = C,$$

$$\therefore \tan\left(\frac{x}{y}\right) + \ln y = C. \quad (\text{G.S})$$

Reducible to homogeneous DE

Consider the DE $(a_1x + b_1y + c_1)dx \pm (a_2x + b_2y + c_2)dy = 0$.

If $c_1 = c_2 = 0$, then the given DE is homogeneous.

If $c_1 \neq 0$ or $c_2 \neq 0$, the given DE is nonhomogeneous, then consider the lines:

$$a_1x + b_1y + c_1 = 0 \quad \text{and} \quad a_2x + b_2y + c_2 = 0.$$

* If $\left(\begin{matrix} a_1 & b_1 \\ a_2 & b_2 \end{matrix} \right)$, then the two lines intersect at a point such as $p(h,k)$, and the given

DE can be reduced to a homogeneous DE by the two substitutions:

$$x = x^* + h \quad \text{and} \quad y = y^* + k.$$

* If $\left(\begin{matrix} a_1 & b_1 \\ a_2 & b_2 \end{matrix} \right)$, then the two lines are parallel, and the given DE becomes

$$[r(a_2x + b_2y) + c_1]dx \pm [(a_2x + b_2y) + c_2]dy = 0,$$

and the given DE can be reduced to a separable variables DE by the substitution:

$$z = a_2x + b_2y.$$

Example 1: Solve $(x - 4y - 3)dx - (x - 6y - 5)dy = 0$.

Solution :

$$\frac{a_1}{a_2} = \frac{1}{1} = 1 \quad \text{and} \quad \frac{b_1}{b_2} = \frac{-4}{-6} = \frac{2}{3}.$$

Since $\frac{a_1}{a_2} \neq \frac{b_1}{b_2}$, then the two lines intersect. To find the point of intersection,

$$x - 4y - 3 = 0, \quad \dots\dots\dots (1)$$

$$x - 6y - 5 = 0. \quad \dots\dots\dots (2)$$

Subtracting Eq.2 from Eq.1 gives $2y + 2 = 0 \Rightarrow y = -1 \Rightarrow x = -1$.

Thus the point of intersection $p(h,k)$ is $p(-1,-1)$.

$$\therefore \text{ Let } x = x^* + h = x^* - 1 \quad \Rightarrow \quad dx = dx^*,$$

$$\text{and } y = y^* + k = y^* - 1 \quad \Rightarrow \quad dy = dy^*,$$

$$\therefore [(x^* - 1) - 4(y^* - 1) - 3]dx^* - [(x^* - 1) - 6(y^* - 1) - 5]dy^* = 0,$$

$$\Rightarrow (x^* - 4y^*)dx^* - (x^* - 6y^*)dy^* = 0. \quad (\text{Homogeneous DE})$$

$$\text{Let } y^* = ux^* \Rightarrow dy^* = u.dx^* + x^*.du,$$

$$\therefore [x^* - 4(ux^*)]dx^* - [x^* - 6(ux^*)](u.dx^* + x^*.du) = 0,$$

$$\Rightarrow (1 - 5u + 6u^2)dx^* - x^*(1 - 6u)du = 0, \quad (\text{Separable DE})$$

$$\frac{dx^*}{x^*} - \frac{1 - 6u}{6u^2 - 5u + 1} du = 0 \Rightarrow \int \frac{dx^*}{x^*} - \int \frac{1 - 6u}{6u^2 - 5u + 1} du = \int 0.$$

$$\text{For } \frac{1 - 6u}{6u^2 - 5u + 1} = \frac{1 - 6u}{(3u - 1)(2u - 1)} = \frac{A}{(3u - 1)} + \frac{B}{(2u - 1)},$$

$$\Rightarrow 1 - 6u = A(2u - 1) + B(3u - 1),$$

$$\text{At } u = \frac{1}{3} \Rightarrow 1 - 6\left(\frac{1}{3}\right) = A\left[2\left(\frac{1}{3}\right) - 1\right] + 0 \Rightarrow -1 = A\left(\frac{-1}{3}\right) \Rightarrow A = 3.$$

$$\text{At } u = \frac{1}{2} \Rightarrow 1 - 6\left(\frac{1}{2}\right) = 0 + B\left[3\left(\frac{1}{2}\right) - 1\right] \Rightarrow -2 = B\left(\frac{1}{2}\right) \Rightarrow B = -4.$$

$$\therefore \int \frac{dx^*}{x^*} - \int \left[\frac{3}{(3u - 1)} + \frac{-4}{(2u - 1)} \right] du = \int 0 \Rightarrow \ln x^* - \ln(3u - 1) + 2\ln(2u - 1) = C_1,$$

$$\Rightarrow \ln \left[\frac{x^*(2u - 1)^2}{(3u - 1)} \right] = C_1 \Rightarrow \frac{x^*(2u - 1)^2}{(3u - 1)} = e^{C_1} \Rightarrow \frac{x^* \left[2 \left(\frac{y^*}{x^*} \right) - 1 \right]^2}{\left[3 \left(\frac{y^*}{x^*} \right) - 1 \right]} = C \quad [C = e^{C_1}],$$

$$\Rightarrow \frac{x^* \left[\frac{2y^* - x^*}{x^*} \right]^2}{\left[\frac{3y^* - x^*}{x^*} \right]} = C \Rightarrow \frac{(2y^* - x^*)^2}{(3y^* - x^*)} = C,$$

$$\Rightarrow \frac{[2(y + 1) - (x + 1)]^2}{[3(y + 1) - (x + 1)]} = C \Rightarrow (2y - x + 1)^2 = C(3y - x + 2). \quad (\text{G.S})$$

Example 2: Solve $(4x + 6y + 1)dy - (2x + 3y + 4)dx = 0$.

Solution :

$$\frac{a_1}{a_2} = \frac{4}{2} = 2 \quad \text{and} \quad \frac{b_1}{b_2} = \frac{6}{3} = 2.$$

Since $\frac{a_1}{a_2} = \frac{b_1}{b_2}$, then the two lines are parallel.

$$[2(2x+3y)+1]dy - (2x+3y+4)dx = 0,$$

$$\text{Let } z = 2x + 3y \quad \Rightarrow \quad dz = 2dx + 3dy \quad \Rightarrow \quad dy = \frac{1}{3}(dz - 2dx),$$

$$\therefore (2z+1)\left[\frac{1}{3}(dz - 2dx)\right] - (z+4)dx = 0,$$

$$\Rightarrow (2z+1)dz - 7(z+2)dx = 0, \quad (\text{Separable DE})$$

$$\Rightarrow \frac{2z+1}{z+2}dz - 7dx = 0 \quad \Rightarrow \quad \int \frac{2z+1}{z+2}dz - \int 7dx = \int 0.$$

$$\text{For } \frac{2z+1}{z+2} = \frac{2(z+2)-3}{z+2} = 2 - \frac{3}{z+2},$$

$$\therefore \int \left[2 - \frac{3}{z+2}\right]dz - \int 7dx = \int 0 \quad \Rightarrow \quad 2z - 3\ln(z+2) - 7x = C_1,$$

$$\Rightarrow 2(2x+3y) - 3\ln(2x+3y+2) - 7x = C_1$$

$$\Rightarrow 3\ln(2x+3y+2) = 6y - 3x - C_1$$

$$\Rightarrow \ln(2x+3y+2) = 2y - x + C. \quad \left[C = -\frac{C_1}{3}\right] \quad (\text{G.S})$$

3- Exact differential equations

Theorem: The differential equation $M(x, y)dx + N(x, y)dy = 0$ is exact if and only if

$$\frac{\partial M}{\partial y} = \frac{\partial N}{\partial x}.$$

Proof: Let $f(x, y) = C$ be any function, then the total differentiation (exact differential) of $f(x, y)$ is given by;

$$df = \frac{\partial f}{\partial x}.dx + \frac{\partial f}{\partial y}.dy = 0.$$

Let $\frac{\partial f}{\partial x} = M(x, y)$ and $\frac{\partial f}{\partial y} = N(x, y)$, then

$$\therefore M(x, y).dx + N(x, y).dy = 0.$$

We have $\frac{\partial M}{\partial y} = \frac{\partial^2 f}{\partial y \partial x}$ and $\frac{\partial N}{\partial x} = \frac{\partial^2 f}{\partial x \partial y}$.

But $\frac{\partial^2 f}{\partial y \partial x} = \frac{\partial^2 f}{\partial x \partial y} \Rightarrow \therefore \frac{\partial M}{\partial y} = \frac{\partial N}{\partial x}$.

To solve an exact DE we use the following procedure;

$$\frac{\partial f}{\partial x} = M(x, y) \Rightarrow f(x, y) = \int M(x, y).dx + g(y),$$

Since $f(x, y) = C \Rightarrow \int M(x, y).dx + g(y) = C$.

To find $g(y)$,

$$\frac{\partial f}{\partial y} = \frac{\partial}{\partial y} [\int M(x, y).dx] + g'(y), \quad \text{but} \quad \frac{\partial f}{\partial y} = N(x, y),$$

$$\therefore \frac{\partial}{\partial y} [\int M(x, y).dx] + g'(y) = N(x, y) \Rightarrow g'(y) = N(x, y) - \frac{\partial}{\partial y} [\int M(x, y).dx],$$

$$\therefore g(y) = \int \left[N(x, y) - \frac{\partial}{\partial y} [\int M(x, y).dx] \right] dy.$$

Example 1: Solve $(3x^2y + 2xy)dx + (x^3 + x^2 + 2y)dy = 0$.

Solution :

$$M(x, y) = 3x^2y + 2xy \Rightarrow \frac{\partial M}{\partial y} = 3x^2 + 2x,$$

$$N(x, y) = x^3 + x^2 + 2y \Rightarrow \frac{\partial N}{\partial x} = 3x^2 + 2x.$$

Since $\frac{\partial M}{\partial y} = \frac{\partial N}{\partial x}$, then the given DE is an exact DE.

* *Solution I;*

$$M(x, y) = \frac{\partial f}{\partial x} = 3x^2y + 2xy \Rightarrow f(x, y) = x^3y + x^2y + g(y),$$

$$\frac{\partial f}{\partial y} = x^3 + x^2 + g'(y), \quad \text{but} \quad \frac{\partial f}{\partial y} = N(x, y),$$

$$\begin{aligned} \therefore x^3 + x^2 + g'(y) = N(x, y) = x^3 + x^2 + 2y &\Rightarrow g'(y) = 2y \Rightarrow g(y) = y^2, \\ \therefore f(x, y) = x^3y + x^2y + y^2, &\quad \text{but} \quad f(x, y) = C, \\ \therefore x^3y + x^2y + y^2 = C. &\quad \text{(G.S)} \end{aligned}$$

* *Solution II;*

$$\begin{aligned} N(x, y) = \frac{\partial f}{\partial y} = x^3 + x^2 + 2y &\Rightarrow f(x, y) = x^3y + x^2y + y^2 + q(x), \\ \frac{\partial f}{\partial x} = 3x^2y + 2xy + q'(x), &\quad \text{but} \quad \frac{\partial f}{\partial x} = M(x, y), \\ \therefore 3x^2y + 2xy + q'(x) = M(x, y) = 3x^2y + 2xy &\Rightarrow q'(x) = 0 \Rightarrow q(x) = C_1, \\ \therefore f(x, y) = x^3y + x^2y + y^2 + C_1, &\quad \text{but} \quad f(x, y) = C_2, \\ \therefore x^3y + x^2y + y^2 + C_1 = C_2 &\Rightarrow x^3y + x^2y + y^2 = C. \quad [C = C_2 - C_1] \quad \text{(G.S)} \end{aligned}$$

* *Solution III;*

$$\begin{aligned} M(x, y) = \frac{\partial f}{\partial x} = 3x^2y + 2xy &\Rightarrow f(x, y) = x^3y + x^2y + g(y), \\ N(x, y) = \frac{\partial f}{\partial y} = x^3 + x^2 + 2y &\Rightarrow f(x, y) = x^3y + x^2y + y^2 + q(x), \end{aligned}$$

Comparing the above two expressions of $f(x, y)$ yields,

$$\begin{aligned} g(y) = y^2 \quad \text{and} \quad q(x) = 0, \\ \therefore f(x, y) = x^3y + x^2y + y^2, &\quad \text{but} \quad f(x, y) = C, \\ \therefore x^3y + x^2y + y^2 = C. &\quad \text{(G.S)} \end{aligned}$$

Example 2: Solve $(x^2 \cos xy + e^y)dy + (xy \cos xy + \sin xy)dx = 0$.

Solution :

$$M(x, y) = xy \cos xy + \sin xy \Rightarrow \frac{\partial M}{\partial y} = x[y(-\sin xy)x + \cos xy] + \cos xy(x),$$

$$\begin{aligned}
&= -x^2 y \sin xy + 2x \cos xy, \\
N(x, y) = x^2 \cos xy + e^y &\Rightarrow \frac{\partial N}{\partial x} = x^2 (-\sin xy) y + \cos xy (2x) + 0, \\
&= -x^2 y \sin xy + 2x \cos xy.
\end{aligned}$$

Since $\frac{\partial M}{\partial y} = \frac{\partial N}{\partial x}$, then the given DE is an exact DE.

$$N = \frac{\partial f}{\partial y} = x^2 \cos xy + e^y \Rightarrow f = x \sin xy + e^y + g(x),$$

$$\frac{\partial f}{\partial x} = x(\cos xy)y + \sin xy + 0 + g'(x), \quad \text{but} \quad \frac{\partial f}{\partial x} = M,$$

$$\therefore xy \cos xy + \sin xy + g'(x) = M = xy \cos xy + \sin xy \Rightarrow g'(x) = 0 \Rightarrow g(x) = C_1,$$

$$\therefore f = x \sin xy + e^y + C_1, \quad \text{but} \quad f = C_2,$$

$$\therefore x \sin xy + e^y + C_1 = C_2 \Rightarrow x \sin xy + e^y = C. \quad [C = C_2 - C_1] \quad (\text{G.S})$$

Reducible to exact differential equations

The differential equation $M(x, y)dx + N(x, y)dy = 0$ which is not exact (i.e. $\frac{\partial M}{\partial y} \neq \frac{\partial N}{\partial x}$) can be reduced to exact DE by multiplying it by a suitable function $\mu(x, y)$ which is called *integrating factor (I.F)*,

$$\mu M dx + \mu N dy = 0.$$

The above new DE is exact if $\frac{\partial}{\partial y}(\mu M) = \frac{\partial}{\partial x}(\mu N)$,

$$\therefore \mu \frac{\partial M}{\partial y} + M \frac{\partial \mu}{\partial y} = \mu \frac{\partial N}{\partial x} + N \frac{\partial \mu}{\partial x}. \quad \dots\dots\dots (1)$$

The integrating factor $\mu(x, y)$ may be a function of x only, function of y only, or a function of both x and y .

There are two methods to find the integrating factor:

I) By equations

i- If $\frac{1}{N}\left(\frac{\partial M}{\partial y} - \frac{\partial N}{\partial x}\right)$ is a function of x only ($\mu(x, y)$ is a function of x only),

$\therefore \frac{\partial \mu}{\partial y} = 0$ and $\frac{\partial \mu}{\partial x} = \frac{d\mu}{dx}$, then Eq.(1) becomes

$$\mu \frac{\partial M}{\partial y} = \mu \frac{\partial N}{\partial x} + N \frac{d\mu}{dx} \quad \Rightarrow \quad \mu \left(\frac{\partial M}{\partial y} - \frac{\partial N}{\partial x} \right) = N \frac{d\mu}{dx},$$

$$\Rightarrow \quad \frac{d\mu}{\mu} = \frac{1}{N} \left(\frac{\partial M}{\partial y} - \frac{\partial N}{\partial x} \right) dx \quad \Rightarrow \quad \ln \mu = \int \frac{1}{N} \left(\frac{\partial M}{\partial y} - \frac{\partial N}{\partial x} \right) dx$$

$$\therefore \mu = e^{\int \frac{1}{N} \left(\frac{\partial M}{\partial y} - \frac{\partial N}{\partial x} \right) dx}.$$

Example 1: Solve $(x + 3y^2)dx + 2xydy = 0$.

Solution :

$$M(x, y) = x + 3y^2 \quad \Rightarrow \quad \frac{\partial M}{\partial y} = 6y,$$

$$N(x, y) = 2xy \quad \Rightarrow \quad \frac{\partial N}{\partial x} = 2y.$$

Since $\frac{\partial M}{\partial y} \neq \frac{\partial N}{\partial x}$, then the given DE is not exact.

$$\text{Check,} \quad \frac{1}{N} \left(\frac{\partial M}{\partial y} - \frac{\partial N}{\partial x} \right) = \frac{1}{2xy} (6y - 2y) = \frac{2}{x} \quad (\text{function of } x \text{ only})$$

$$\therefore \mu = e^{\int \frac{1}{N} \left(\frac{\partial M}{\partial y} - \frac{\partial N}{\partial x} \right) dx} \quad \Rightarrow \quad \mu = e^{\int \frac{2}{x} dx} = e^{2 \ln x} = e^{\ln x^2} = x^2.$$

Multiplying the given DE by the above integrating factor (I.F) gives

$$x^2(x + 3y^2)dx + x^2(2xy)dy = 0 \quad \Rightarrow \quad (x^3 + 3x^2y^2)dx + 2x^3ydy = 0.$$

$$\text{Check,} \quad M(x, y) = x^3 + 3x^2y^2 \quad \Rightarrow \quad \frac{\partial M}{\partial y} = 6x^2y,$$

$$N(x, y) = 2x^3y \quad \Rightarrow \quad \frac{\partial N}{\partial x} = 6x^2y.$$

Since $\frac{\partial M}{\partial y} = \frac{\partial N}{\partial x}$, then the given DE is reduced to exact one.

$$M = \frac{\partial f}{\partial x} = x^3 + 3x^2y^2 \quad \Rightarrow \quad f = \frac{x^4}{4} + x^3y^2 + g(y),$$

$$\frac{\partial f}{\partial y} = 2x^3y + g'(y), \quad \text{but} \quad \frac{\partial f}{\partial y} = N,$$

$$\therefore 2x^3y + g'(y) = N = 2x^3y \quad \Rightarrow \quad g'(y) = 0 \quad \Rightarrow \quad g(y) = C_1,$$

$$\therefore f = \frac{x^4}{4} + x^3y^2 + C_1, \quad \text{but} \quad f = C_2,$$

$$\therefore \frac{x^4}{4} + x^3y^2 + C_1 = C_2 \quad \Rightarrow \quad \frac{x^4}{4} + x^3y^2 = C_3, \quad [C_3 = C_2 - C_1]$$

or $x^4 + 4x^3y^2 = C. \quad [C = 4C_3] \quad \text{(G.S)}$

Example 2: Solve $(\sin y + x^2 + 2x)dx = \cos y dy$.

Solution :

$$(\sin y + x^2 + 2x)dx = \cos y dy \quad \Rightarrow \quad (\sin y + x^2 + 2x)dx - \cos y dy = 0.$$

$$M(x, y) = \sin y + x^2 + 2x \quad \Rightarrow \quad \frac{\partial M}{\partial y} = \cos y,$$

$$N(x, y) = -\cos y \quad \Rightarrow \quad \frac{\partial N}{\partial x} = 0.$$

Since $\frac{\partial M}{\partial y} \neq \frac{\partial N}{\partial x}$, then the given DE is not exact.

Check, $\frac{1}{N} \left(\frac{\partial M}{\partial y} - \frac{\partial N}{\partial x} \right) = \frac{1}{-\cos y} (\cos y - 0) = -1 \quad \text{(function of } x \text{ only)}$

$$\therefore \mu = e^{\int \frac{1}{N} \left(\frac{\partial M}{\partial y} - \frac{\partial N}{\partial x} \right) dx} \quad \Rightarrow \quad \mu = e^{\int (-1) dx} = e^{-x}.$$

Multiplying the given DE by the above integrating factor (I.F) gives

$$e^{-x}(\sin y + x^2 + 2x)dx - e^{-x} \cos y dy = 0.$$

$$N = \frac{\partial f}{\partial y} = -e^{-x} \cos y \quad \Rightarrow \quad f = -e^{-x} \sin y + g(x),$$

$$\frac{\partial f}{\partial x} = e^{-x} \sin y + g'(x), \quad \text{but} \quad \frac{\partial f}{\partial x} = M,$$

$$\therefore e^{-x} \sin y + g'(x) = M = e^{-x}(\sin y + x^2 + 2x) \quad \Rightarrow \quad g'(x) = x^2 e^{-x} + 2x e^{-x},$$

$$\therefore g(x) = -x^2 e^{-x} - 2x e^{-x} - 2e^{-x} - 2x e^{-x} - 2e^{-x} \Rightarrow g(x) = -x^2 e^{-x} - 4x e^{-x} - 4e^{-x},$$

$$\therefore f = -e^{-x} \sin y - x^2 e^{-x} - 4x e^{-x} - 4e^{-x}, \quad \text{but} \quad f = C,$$

$$\therefore -e^{-x} \sin y - x^2 e^{-x} - 4x e^{-x} - 4e^{-x} = C_1,$$

$$\text{or} \quad x^2 + 4x + 4 + \sin y = C e^x. \quad [C = -C_1] \quad (\text{G.S})$$

Note;

<u>u</u>	<u>dv</u>
x^2	e^{-x}
$2x$	$-e^{-x}$
2	e^{-x}
0	$-e^{-x}$
$\int x^2 e^{-x} dx = x^2(-e^{-x}) - 2x e^{-x} + 2(-e^{-x})$ $= -x^2 e^{-x} - 2x e^{-x} - 2e^{-x}$	
<u>u</u>	<u>dv</u>
$2x$	e^{-x}
2	$-e^{-x}$
0	e^{-x}
$\int 2x e^{-x} dx = 2x(-e^{-x}) - 2e^{-x}$ $= -2x e^{-x} - 2e^{-x}$	

ii- If $\frac{1}{M} \left(\frac{\partial M}{\partial y} - \frac{\partial N}{\partial x} \right)$ is a function of y only ($\mu(x, y)$ is a function of y only),

$\therefore \frac{\partial \mu}{\partial x} = 0$ and $\frac{\partial \mu}{\partial y} = \frac{d\mu}{dy}$, then Eq.(1) becomes

$$\mu \frac{\partial M}{\partial y} + M \frac{d\mu}{dy} = \mu \frac{\partial N}{\partial x} \quad \Rightarrow \quad \mu \left(\frac{\partial M}{\partial y} - \frac{\partial N}{\partial x} \right) = -M \frac{d\mu}{dy},$$

$$\Rightarrow \quad \frac{d\mu}{\mu} = \frac{-1}{M} \left(\frac{\partial M}{\partial y} - \frac{\partial N}{\partial x} \right) dy \quad \Rightarrow \quad \ln \mu = \int \frac{-1}{M} \left(\frac{\partial M}{\partial y} - \frac{\partial N}{\partial x} \right) dy$$

$$\therefore \mu = e^{-\int \frac{1}{M} \left(\frac{\partial M}{\partial y} - \frac{\partial N}{\partial x} \right) dy}.$$

Example 1: Solve $(y + 2x)dx + x(y + x + 1)dy = 0$.

Solution :

$$M(x, y) = y + 2x \quad \Rightarrow \quad \frac{\partial M}{\partial y} = 1,$$

$$N(x, y) = xy + x^2 + x \quad \Rightarrow \quad \frac{\partial N}{\partial x} = y + 2x + 1.$$

Since $\frac{\partial M}{\partial y} \neq \frac{\partial N}{\partial x}$, then the given DE is not exact.

$$\text{Check, } \frac{1}{N} \left(\frac{\partial M}{\partial y} - \frac{\partial N}{\partial x} \right) = \frac{1 - (y + 2x + 1)}{xy + x^2 + x} = \frac{-(y + 2x)}{x(y + x + 1)} \quad (\text{is not function of } x \text{ only})$$

$$\text{Check, } \frac{1}{M} \left(\frac{\partial M}{\partial y} - \frac{\partial N}{\partial x} \right) = \frac{1 - (y + 2x + 1)}{y + 2x} = \frac{-(y + 2x)}{y + 2x} = -1 \quad (\text{function of } y \text{ only})$$

$$\therefore \mu = e^{-\int \frac{1}{M} \left(\frac{\partial M}{\partial y} - \frac{\partial N}{\partial x} \right) dy} \Rightarrow \mu = e^{-\int (-1) dy} = e^y.$$

Multiplying the given DE by the above integrating factor (I.F) gives

$$e^y (y + 2x)dx + xe^y (y + x + 1)dy = 0.$$

$$M = \frac{\partial f}{\partial x} = ye^y + 2xe^y \quad \Rightarrow \quad f = xye^y + x^2e^y + g(y),$$

$$\frac{\partial f}{\partial y} = xye^y + xe^y + x^2e^y + g'(y), \quad \text{but} \quad \frac{\partial f}{\partial y} = N,$$

$$\therefore xye^y + xe^y + x^2e^y + g'(y) = N = xye^y + x^2e^y + xe^y \Rightarrow g'(y) = 0 \Rightarrow g(y) = C_1,$$

$$\therefore f = xye^y + x^2e^y + C_1, \quad \text{but} \quad f = C_2,$$

$$\therefore xye^y + x^2e^y + C_1 = C_2 \Rightarrow xy + x^2 = Ce^{-y}. \quad [C = C_2 - C_1] \quad (\text{G.S})$$

Example 2: Solve $\cos y \cdot dx + (2x \sin y - \cos^3 y) \cdot dy = 0$.

Solution :

$$M = \cos y \quad \Rightarrow \quad \frac{\partial M}{\partial y} = -\sin y,$$

$$N = 2x \sin y - \cos^3 y \quad \Rightarrow \quad \frac{\partial N}{\partial x} = 2 \sin y.$$

Since $\frac{\partial M}{\partial y} \neq \frac{\partial N}{\partial x}$, then the given DE is not exact.

$$\text{Check, } \frac{1}{N} \left(\frac{\partial M}{\partial y} - \frac{\partial N}{\partial x} \right) = \frac{-\sin y - 2 \sin y}{2x \sin y - \cos^3 y} = \frac{-3 \sin y}{2x \sin y - \cos^3 y} \quad (\text{is not function of } x \text{ only})$$

$$\text{Check, } \frac{1}{M} \left(\frac{\partial M}{\partial y} - \frac{\partial N}{\partial x} \right) = \frac{-\sin y - 2 \sin y}{\cos y} = \frac{-3 \sin y}{\cos y}, \quad (\text{function of } y \text{ only})$$

$$\therefore \mu = e^{-\int \frac{1}{M} \left(\frac{\partial M}{\partial y} - \frac{\partial N}{\partial x} \right) dy} \Rightarrow \mu = e^{-\int \frac{-3 \sin y}{\cos y} dy} = e^{-3 \ln \cos y} = \cos^{-3} y = \frac{1}{\cos^3 y}.$$

Multiplying the given DE by the above integrating factor (I.F) gives

$$\frac{1}{\cos^3 y} (\cos y) dx + \frac{1}{\cos^3 y} (2x \sin y - \cos^3 y) dy = 0 \Rightarrow \frac{1}{\cos^2 y} dx + \left(\frac{2x \sin y}{\cos^3 y} - 1 \right) dy = 0$$

$$M = \frac{\partial f}{\partial x} = \frac{1}{\cos^2 y} \quad \Rightarrow \quad f = \frac{x}{\cos^2 y} + g(y),$$

$$\frac{\partial f}{\partial y} = -2x \cos^{-3} \cdot (-\sin y) + g'(y) = \frac{2x \sin y}{\cos^3 y} + g'(y), \quad \text{but} \quad \frac{\partial f}{\partial y} = N,$$

$$\therefore \frac{2x \sin y}{\cos^3 y} + g'(y) = N = \frac{2x \sin y}{\cos^3 y} - 1 \quad \Rightarrow \quad g'(y) = -1 \quad \Rightarrow \quad g(y) = -y,$$

$$\therefore f = \frac{x}{\cos^2 y} - y, \quad \text{but} \quad f = C,$$

$$\therefore \frac{x}{\cos^2 y} - y = C, \quad \text{or} \quad x = (y + C) \cos^2 y. \quad (\text{G.S})$$

iii- If $\mu(x, y)$ is a function of x and y , then a partial DE should be used.

II) By inspection

Inspection may be used when the integrating factor is simple such that it can be expected. This occurs when the DE can be rewritten as one of the following forms:

Differential expression	Integrating factor	Exact differential
$x.dy + y.dx$	1	$x.dy + y.dx = d(xy)$
$x.dy + y.dx$	$\frac{1}{xy}$	$\frac{x dy + y dx}{xy} = d(\ln xy)$
$x.dy + y.dx$	$\frac{1}{x^2 y^2}$	$\frac{x dy + y dx}{x^2 y^2} = -d\left(\frac{1}{xy}\right)$
$x.dy - y.dx$	$\frac{1}{x^2}$	$\frac{x dy - y dx}{x^2} = d\left(\frac{y}{x}\right)$
$x.dy - y.dx$	$\frac{1}{y^2}$	$\frac{x dy - y dx}{y^2} = -d\left(\frac{x}{y}\right)$
$x.dy - y.dx$	$\frac{1}{xy}$	$\frac{x dy - y dx}{xy} = d\left(\ln \frac{y}{x}\right) = -d\left(\ln \frac{x}{y}\right)$
$x.dy - y.dx$	$\frac{2}{x^2 - y^2}$	$\frac{2x dy - 2y dx}{x^2 - y^2} = d\left(\ln \frac{x+y}{x-y}\right) = -d\left(\ln \frac{x-y}{x+y}\right)$
$x.dy - y.dx$	$\frac{1}{x^2 + y^2}$	$\frac{x dy - y dx}{x^2 + y^2} = d\left(\tan^{-1} \frac{y}{x}\right) = -d\left(\tan^{-1} \frac{x}{y}\right)$
$x.dy - y.dx$	$\frac{1}{x\sqrt{x^2 + y^2}}$	$\frac{x dy - y dx}{x\sqrt{x^2 + y^2}} = d\left(\sinh^{-1} \frac{y}{x}\right)$
$x.dy - y.dx$	$\frac{1}{y\sqrt{x^2 + y^2}}$	$\frac{x dy - y dx}{y\sqrt{x^2 + y^2}} = -d\left(\sinh^{-1} \frac{x}{y}\right)$
$x.dx + y.dy$	2	$2x dx + 2y dy = d(x^2 + y^2)$
$x.dx + y.dy$	$\frac{2}{x^2 + y^2}$	$\frac{2x dx + 2y dy}{x^2 + y^2} = d[\ln(x^2 + y^2)]$
$x.dx + y.dy$	$\frac{1}{\sqrt{x^2 + y^2}}$	$\frac{x dx + y dy}{\sqrt{x^2 + y^2}} = d(\sqrt{x^2 + y^2})$
$x.dx - y.dy$	$\frac{1}{\sqrt{x^2 - y^2}}$	$\frac{x dx - y dy}{\sqrt{x^2 - y^2}} = d(\sqrt{x^2 - y^2})$

Example 1: Solve $x.dy + (x^3 - y).dx = 0$.

Solution :

$$x.dy + (x^3 - y).dx = 0 \quad \Rightarrow \quad x dy - y dx + x^3 dx = 0,$$

$$\Rightarrow \frac{x dy - y dx}{x^2} + x dx = 0 \quad \Rightarrow \quad d\left(\frac{y}{x}\right) + x dx = 0,$$

$$\therefore \frac{y}{x} + \frac{x^2}{2} = C_1 \quad \text{or} \quad 2y + x^3 = Cx. \quad [C = 2C_1] \quad (\text{G.S})$$

Example 2: Solve $x.dx + (y - \sqrt{x^2 + y^2}).dy = 0$.

Solution :

$$\begin{aligned}x.dx + (y - \sqrt{x^2 + y^2}).dy = 0 &\Rightarrow xdx + ydy - \sqrt{x^2 + y^2} dy = 0, \\ \Rightarrow \frac{xdx + ydy}{\sqrt{x^2 + y^2}} - dy = 0 &\Rightarrow d\left(\sqrt{x^2 + y^2}\right) - dy = 0 \\ \therefore \sqrt{x^2 + y^2} - y = C. &\quad \text{(G.S)}\end{aligned}$$

Example 3: Solve $y.dx - (x^2 + y^2 + x).dy = 0$.

Solution :

$$\begin{aligned}y.dx - (x^2 + y^2 + x).dy = 0 &\Rightarrow -xdy + ydx - (x^2 + y^2)dy = 0, \\ \Rightarrow xdy - ydx + (x^2 + y^2)dy = 0 &\Rightarrow \frac{xdy - ydx}{x^2 + y^2} + dy = 0, \\ \Rightarrow d\left(\tan^{-1}\frac{y}{x}\right) + dy = 0 &\Rightarrow \tan^{-1}\frac{y}{x} + y = C, \\ \text{or } \tan^{-1}\frac{y}{x} = C - y &\Rightarrow \frac{y}{x} = \tan(C - y) \Rightarrow x = \frac{y}{\tan(C - y)}. \quad \text{(G.S)}\end{aligned}$$

Example 4: Solve $(xy^2 + y).dx + x.dy = 0$.

Solution :

$$\begin{aligned}(xy^2 + y).dx + x.dy = 0 &\Rightarrow xy^2 dx + xdy + ydx = 0, \\ \Rightarrow \frac{dx}{x} + \frac{xdy + ydx}{x^2 y^2} = 0 &\Rightarrow \frac{dx}{x} - d\left(\frac{1}{xy}\right) = 0, \\ \Rightarrow \ln x - \frac{1}{xy} = C. &\quad \text{(G.S)}\end{aligned}$$

Example 5: Solve $2y^2 dx + (2x + 3xy)dy = 0$.

Solution :

$$2y^2 dx + (2x + 3xy)dy = 0 \Rightarrow 2y^2 dx + 3xydy + 2xdy = 0, \quad (\times xy)$$

$$\Rightarrow 2xy^3 dx + 3x^2 y^2 dy + 2x^2 y dy = 0 \Rightarrow d(x^2 y^3) + 2x^2 y dy = 0, \quad (\times \frac{1}{x^2 y^3})$$

$$\Rightarrow \frac{d(x^2 y^3)}{x^2 y^3} + \frac{2}{y^2} dy = 0 \Rightarrow \ln(x^2 y^3) - \frac{2}{y} = C,$$

$$\text{or } y \ln(x^2 y^3) - 2 = Cy. \quad (\text{G.S})$$

4- Linear differential equations

The general form of the first order linear differential equation is

$$\frac{dy}{dx} + P(x).y = Q(x).$$

(Note that if $P(x) = 0$ or $Q(x) = 0$, then the above DE is a separable variables DE).

If the above linear DE is not exact DE, so it can be reduced to exact one by multiplying it with a suitable integrating factor which can be found as follows,

$$\frac{dy}{dx} + P(x).y = Q(x) \Rightarrow dy + P(x).y dx = Q(x) dx \Rightarrow [P(x)y - Q(x)] dx + dy = 0,$$

$$M(x, y) = P(x)y - Q(x) \Rightarrow \frac{\partial M}{\partial y} = P(x),$$

$$N(x, y) = 1 \Rightarrow \frac{\partial N}{\partial x} = 0.$$

$$\frac{1}{N} \left(\frac{\partial M}{\partial y} - \frac{\partial N}{\partial x} \right) = \frac{P(x) - 0}{1} = P(x) \quad (\text{function of } x \text{ only})$$

$$\therefore \mu = e^{\int \frac{1}{N} \left(\frac{\partial M}{\partial y} - \frac{\partial N}{\partial x} \right) dx} \Rightarrow \mu = e^{\int P(x) dx}.$$

Multiplying the given DE by the above integrating factor (I.F) gives

$$e^{\int P(x) dx} [P(x)y - Q(x)] dx + e^{\int P(x) dx} dy = 0,$$

$$\Rightarrow e^{\int P(x) dx} . P(x)y dx + e^{\int P(x) dx} dy - Q(x). e^{\int P(x) dx} dx = 0,$$

$$\Rightarrow d \left[e^{\int P(x) dx} . y \right] = Q(x). e^{\int P(x) dx} dx \Rightarrow \therefore e^{\int P(x) dx} . y = \int Q(x). e^{\int P(x) dx} dx + C.$$

$$\text{Or simply } \mu . y = \int \mu . Q dx + C.$$

Example 1: Solve $(x^2 + x)dy = (x^5 + 3xy + 3y)dx$.

Solution :

$$(x^2 + x)dy = (x^5 + 3xy + 3y)dx \quad \Rightarrow \quad x(x+1)\frac{dy}{dx} = x^5 + 3y(x+1),$$

$$\Rightarrow \frac{dy}{dx} = \frac{x^4}{x+1} + \frac{3y}{x} \Rightarrow \frac{dy}{dx} - \frac{3}{x}y = \frac{x^4}{x+1}, \quad (\text{Linear DE with respect to } y)$$

$$\text{where,} \quad P(x) = \frac{-3}{x} \quad \text{and} \quad Q(x) = \frac{x^4}{x+1}.$$

$$\mu = e^{\int P(x)dx} \Rightarrow \mu = e^{\int \frac{-3}{x} dx} = e^{-3\ln x} = e^{\ln x^{-3}} = x^{-3} = \frac{1}{x^3}.$$

$$\mu \cdot y = \int \mu \cdot Q dx + C \quad \Rightarrow \quad \frac{1}{x^3} \cdot y = \int \frac{1}{x^3} \cdot \frac{x^4}{x+1} dx + C,$$

$$\Rightarrow \frac{y}{x^3} = \int \frac{x}{x+1} dx + C \quad \Rightarrow \quad \frac{y}{x^3} = \int \left[1 + \frac{-1}{x+1}\right] dx + C,$$

$$\Rightarrow \frac{y}{x^3} = x - \ln(x+1) + C \quad \text{or} \quad y = x^3[x - \ln(x+1) + C]. \quad (\text{G.S})$$

Example 2: Solve $(\sin^2 x - y)dx - \tan x dy = 0$.

Solution :

$$(\sin^2 x - y)dx - \tan x dy = 0 \quad \Rightarrow \quad \tan x \frac{dy}{dx} = \sin^2 x - y,$$

$$\Rightarrow \frac{dy}{dx} = \frac{\sin^2 x}{\tan x} - \frac{y}{\tan x} \Rightarrow \frac{dy}{dx} + \frac{1}{\tan x} y = \frac{\sin^2 x}{\tan x}, \quad (\text{Linear DE with respect to } y)$$

$$\text{where,} \quad P(x) = \frac{1}{\tan x} = \frac{\cos x}{\sin x} \quad \text{and} \quad Q(x) = \frac{\sin^2 x}{\tan x} = \sin x \cos x.$$

$$\mu = e^{\int P(x)dx} \Rightarrow \mu = e^{\int \frac{\cos x}{\sin x} dx} = e^{\ln \sin x} = \sin x.$$

$$\mu \cdot y = \int \mu \cdot Q dx + C \quad \Rightarrow \quad \sin x \cdot y = \int \sin x \cdot (\sin x \cos x) dx + C_1,$$

$$\Rightarrow y \sin x = \int \sin^2 x \cos x dx + C_1 \quad \Rightarrow \quad y \sin x = \frac{\sin^3 x}{3} + C_1,$$

or $3y \sin x = \sin^3 x + C. \quad [C = 3C_1] \quad \text{(G.S)}$

Example 3: Solve $(x - 2y)dy + ydx = 0.$

Solution :

$$(x - 2y)dy + ydx = 0 \quad \Rightarrow \quad \frac{dy}{dx} + \frac{y}{x - 2y} = 0. \quad \text{(Nonlinear with respect to } y)$$

$$\text{But } \frac{dx}{dy} + \frac{x - 2y}{y} = 0 \quad \Rightarrow \quad \frac{dx}{dy} + \frac{1}{y}x = 2, \quad \text{(Linear DE with respect to } x)$$

$$\text{where, } P(y) = \frac{1}{y} \quad \text{and} \quad Q(y) = 2.$$

$$\mu = e^{\int P(y)dy} \quad \Rightarrow \quad \mu = e^{\int \frac{1}{y} dy} = e^{\ln y} = y.$$

$$\mu.x = \int \mu.Qdy + C \quad \Rightarrow \quad y.x = \int y.(2)dy + C,$$

$$\Rightarrow \quad xy = y^2 + C. \quad \text{(G.S)}$$

Reducible to linear differential equations

Sometimes a nonlinear DE can be reduced to a linear DE. One set of equations for which this can always be achieved is the class of "**Bernoulli Equation**". These are of the form,

$$\frac{dy}{dx} + P(x).y = Q(x).y^n.$$

When $n=0$ or $n=1$, the above DE is linear.

Consider the case when $n \neq 0,1$; division by y^n yields

$$y^{-n} \frac{dy}{dx} + P(x).y^{1-n} = Q(x).$$

$$\text{Let } z = y^{1-n} \quad \Rightarrow \quad \frac{dz}{dx} = (1-n)y^{-n} \frac{dy}{dx} \quad \Rightarrow \quad y^{-n} \frac{dy}{dx} = \frac{1}{1-n} \cdot \frac{dz}{dx},$$

$$\therefore \frac{1}{1-n} \cdot \frac{dz}{dx} + P(x).z = Q(x),$$

Or $\frac{dz}{dx} + (1-n)P(x).z = (1-n)Q(x)$. (Linear DE with respect to z)

So, Bernoulli's equation can be reduced to a linear DE by the transformation,

$$z = y^{1-n}.$$

Example 1: Solve $xdy + (3y - x^3y^2)dx = 0$.

Solution :

$$xdy + (3y - x^3y^2)dx = 0 \quad \Rightarrow \quad \frac{dy}{dx} + \frac{3y - x^3y^2}{x} = 0,$$

$$\Rightarrow \quad \frac{dy}{dx} + \frac{3}{x}.y = x^2y^2. \quad (\text{Bernoulli's equation})$$

Division by y^2 gives

$$y^{-2} \frac{dy}{dx} + \frac{3}{x}.y^{-1} = x^2.$$

$$\text{Let } z = y^{-1} \quad \Rightarrow \quad \frac{dz}{dx} = -y^{-2} \frac{dy}{dx} \quad \Rightarrow \quad y^{-2} \frac{dy}{dx} = -\frac{dz}{dx},$$

$$\therefore -\frac{dz}{dx} + \frac{3}{x}.z = x^2,$$

$$\Rightarrow \quad \frac{dz}{dx} - \frac{3}{x}.z = -x^2, \quad (\text{Linear DE with respect to } z)$$

where, $P(x) = \frac{-3}{x}$ and $Q(x) = -x^2$.

$$\mu = e^{\int P(x)dx} \quad \Rightarrow \quad \mu = e^{\int \frac{-3}{x} dx} = e^{-3 \ln x} = e^{\ln x^{-3}} = x^{-3} = \frac{1}{x^3}.$$

$$\mu.z = \int \mu.Q dx + C \quad \Rightarrow \quad \frac{1}{x^3}.z = \int \frac{1}{x^3}.(-x^2) dx + C,$$

$$\Rightarrow \quad \frac{z}{x^3} = -\int \frac{1}{x} dx + C \quad \Rightarrow \quad \frac{z}{x^3} = -\ln x + C,$$

$$\Rightarrow \quad z = x^3(C - \ln x). \quad \text{But } z = y^{-1} = \frac{1}{y},$$

$$\therefore \frac{1}{y} = x^3(C - \ln x) \quad \text{or} \quad y = \frac{1}{x^3(C - \ln x)} \quad (\text{G.S})$$

Example 2: Solve $x^2 dx - (\sin y \cos^2 y + x^3 \tan y) dy = 0$.

Solution :

$$x^2 dx - (\sin y \cos^2 y + x^3 \tan y) dy = 0 \Rightarrow \frac{dx}{dy} - \frac{x^2}{\sin y \cos^2 y + x^3 \tan y} = 0 \quad (\text{Nonlinear})$$

$$\text{But } \frac{dx}{dy} - \frac{\sin y \cos^2 y + x^3 \tan y}{x^2} = 0 \Rightarrow \frac{dx}{dy} - (\tan y).x = (\sin y \cos^2 y).x^{-2} \quad (\text{Bernoulli})$$

$$\text{Division by } x^{-2} \text{ gives } x^2 \frac{dx}{dy} - (\tan y).x^3 = \sin y \cos^2 y.$$

$$\text{Let } z = x^3 \Rightarrow \frac{dz}{dy} = 3x^2 \frac{dx}{dy} \Rightarrow x^2 \frac{dx}{dy} = \frac{1}{3} \frac{dz}{dy},$$

$$\therefore \frac{1}{3} \frac{dz}{dy} - (\tan y).z = \sin y \cos^2 y \Rightarrow \frac{dz}{dy} - (3 \tan y).z = 3 \sin y \cos^2 y, \quad (\text{Linear w.r.t } z)$$

$$\text{where, } P(y) = -3 \tan y \quad \text{and} \quad Q(y) = 3 \sin y \cos^2 y.$$

$$\mu = e^{\int P(y) dy} \Rightarrow \mu = e^{\int -3 \tan y \cdot dy} = e^{-3 \int \frac{\sin y}{\cos y} dy} = e^{3 \ln \cos y} = \cos^3 y.$$

$$\mu.z = \int \mu.Q dy + C \Rightarrow \cos^3 y.z = \int \cos^3 y.(3 \sin y \cos^2 y) dy + C,$$

$$\Rightarrow \cos^3 y.z = 3 \int \sin y \cdot \cos^5 y \cdot dy + C \Rightarrow \cos^3 y.z = -3 \cdot \frac{\cos^6 y}{6} + C,$$

$$\text{but } z = x^3 \Rightarrow x^3 \cos^3 y = -\frac{\cos^6 y}{2} + C,$$

$$\text{or } x^3 = C \sec^3 y - \frac{1}{2} \cos^3 y. \quad (\text{G.S})$$

5- Second order DE reduced to first order DE

A) When the dependent variable does not appear in the DE;

If the dependent variable (say y) does not appear in a second order DE, then this equation can be reduced to a first order DE by letting

$$z = f(x) = \frac{dy}{dx} \Rightarrow \frac{d}{dx}(z) = \frac{d}{dx}\left(\frac{dy}{dx}\right) \Rightarrow \frac{dz}{dx} = \frac{d^2 y}{dx^2}.$$

Example: Solve $y'' + 2y' = 4x$. (or $\frac{d^2y}{dx^2} + 2\frac{dy}{dx} = 4x$)

Solution :

Since the dependent variable (y) does not appear in the given second order DE, then this equation can be reduced to a first order DE by letting

$$z = f(x) = \frac{dy}{dx} \quad \Rightarrow \quad \frac{dz}{dx} = \frac{d^2y}{dx^2}.$$

$$\therefore \frac{d^2y}{dx^2} + 2\frac{dy}{dx} = 4x \quad \text{is reduced to}$$

$$\frac{dz}{dx} + 2z = 4x, \quad (\text{Linear 1}^{\text{st}} \text{ order DE w.r.t } z)$$

where, $P(x) = 2$ and $Q(x) = 4x$.

$$\mu = e^{\int P(x)dx} \quad \Rightarrow \quad \mu = e^{\int 2dx} = e^{2x}.$$

$$\mu.z = \int \mu.Qdx + C \quad \Rightarrow \quad e^{2x}.z = \int e^{2x}.(4x)dx + C_1,$$

$$\Rightarrow \quad ze^{2x} = 4 \int xe^{2x} dx + C_1 \quad \Rightarrow \quad ze^{2x} = 4 \left[\frac{1}{2} xe^{2x} - \frac{1}{4} e^{2x} \right] + C_1,$$

$$\Rightarrow \quad ze^{2x} = 2xe^{2x} - e^{2x} + C_1 \quad \Rightarrow \quad z = 2x - 1 + C_1 e^{-2x},$$

$$\text{but } z = \frac{dy}{dx} \quad \Rightarrow \quad \therefore \frac{dy}{dx} = 2x - 1 + C_1 e^{-2x}, \quad (\text{Separable DE})$$

$$\Rightarrow \quad y = x^2 - x - \frac{1}{2} C_1 e^{-2x} + C_2. \quad (\text{G.S})$$

B) When the independent variable does not appear in the DE;

If the independent variable (say x) does not appear in a second order DE, then this equation can be reduced to a first order DE by letting

$$z = f(y) = \frac{dy}{dx} \quad \Rightarrow \quad \frac{d}{dx}(z) = \frac{d}{dx}\left(\frac{dy}{dx}\right) \quad \Rightarrow \quad \frac{dz}{dy} \cdot \frac{dy}{dx} = \frac{d^2y}{dx^2},$$

$$\text{but } z = \frac{dy}{dx} \quad \Rightarrow \quad \therefore z \cdot \frac{dz}{dy} = \frac{d^2y}{dx^2}.$$

Example: Solve $4y(y')^2 y'' = (y')^4 + 3$.

Solution :

Since the independent variable (x) does not appear in the given second order DE, then this equation can be reduced to a first order DE by letting

$$z = f(y) = \frac{dy}{dx} \quad \Rightarrow \quad \frac{d}{dx}(z) = \frac{d}{dx}\left(\frac{dy}{dx}\right) \quad \Rightarrow \quad \frac{dz}{dy} \cdot \frac{dy}{dx} = \frac{d^2 y}{dx^2},$$

$$\text{but } z = \frac{dy}{dx} \quad \Rightarrow \quad \therefore z \cdot \frac{dz}{dy} = \frac{d^2 y}{dx^2}.$$

$\therefore 4y(y')^2 y'' = (y')^4 + 3$ is reduced to

$$4yz^2 \left(z \cdot \frac{dz}{dy}\right) = z^4 + 3. \quad (\text{Separable DE})$$

$$\therefore \frac{4z^3 dz}{z^4 + 3} = \frac{dy}{y} \quad \Rightarrow \quad \ln(z^4 + 3) = \ln y + C \quad \Rightarrow \quad \ln\left(\frac{z^4 + 3}{y}\right) = C,$$

$$\Rightarrow \quad \frac{z^4 + 3}{y} = C_1 \quad [\text{where } C_1 = e^C] \quad \Rightarrow \quad z^4 = C_1 y - 3,$$

$$\Rightarrow \quad z = (C_1 y - 3)^{1/4}. \quad \text{But } z = \frac{dy}{dx},$$

$$\therefore \frac{dy}{dx} = (C_1 y - 3)^{1/4}, \quad (\text{Separable DE})$$

$$\therefore \frac{dy}{(C_1 y - 3)^{1/4}} = dx \quad \Rightarrow \quad (C_1 y - 3)^{-1/4} dy = dx,$$

$$\Rightarrow \quad \frac{4}{3C_1} (C_1 y - 3)^{3/4} = x + C_2,$$

$$\text{or } (C_1 y - 3)^{3/4} = \frac{3C_1}{4} (x + C_2). \quad (\text{G.S})$$

3- Applications on First-Order ODE

Introduction

The mathematical formulation of physical problems involving continuously changing quantities, often leads to differential equations of the first-order.

1- Orthogonal Trajectories

In many engineering problems, a family (set) of curves is given and it is required to find another family whose curves intersect each of the given curves at right angle.

Consider the function $f(x, y) = C$ where C is a constant. By changing the value of the constant C , a family (set) of curves are obtained for $f(x, y)$, where each curve has one value of the constant. It is required to find another set of curves which are orthogonal to the first set. This is done by eliminating the constant C from $f(x, y) = C$ by differentiation, and then replacing $\frac{dy}{dx}$ of these curves by $[-1/\frac{dy}{dx}]$ to get the required orthogonal set.

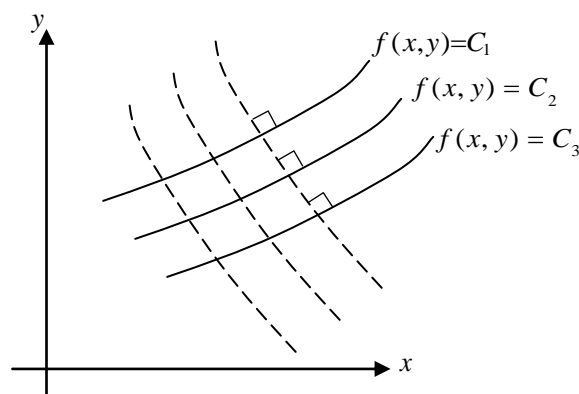

Example 1: Find the orthogonal trajectories of $y = Cx^2$.

Solution:

Step 1; Find the slope of the given set,

Method I,

$$y = Cx^2 \Rightarrow \frac{y}{x^2} = C. \quad \text{By differentiation} \quad \frac{x^2 \cdot dy - y \cdot (2x dx)}{x^4} = 0,$$

$$\Rightarrow x^2 dy - 2xy dx = 0 \Rightarrow \left(\frac{dy}{dx} \right)_1 = \frac{2y}{x}. \quad (\text{The slope of the given set})$$

Method II,

$$y = Cx^2. \quad \text{By differentiation} \quad dy = 2Cx dx \Rightarrow \left(\frac{dy}{dx} \right)_1 = 2Cx.$$

$$\text{From the given set } C = \frac{y}{x^2} \Rightarrow \therefore \left(\frac{dy}{dx} \right)_1 = 2 \left(\frac{y}{x^2} \right) x \Rightarrow \left(\frac{dy}{dx} \right)_1 = \frac{2y}{x}.$$

Step 2; Find the slope of the required set,

$$\text{Since the required and given sets are orthogonal, then } \left(\frac{dy}{dx} \right)_2 = -1 / \left(\frac{dy}{dx} \right)_1.$$

$$\therefore \left(\frac{dy}{dx} \right)_2 = -1 / \left(\frac{2y}{x} \right) \Rightarrow \left(\frac{dy}{dx} \right)_2 = \frac{-x}{2y}.$$

Step 3; Find the required set,

To find the required set we must solve the above differential equation,

$$\frac{dy}{dx} = \frac{-x}{2y} \quad (\text{separable variables DE})$$

$$\Rightarrow 2y dy = -x dx,$$

$$\therefore y^2 = \frac{-x^2}{2} + K \quad \text{or} \quad y^2 + \frac{x^2}{2} = K.$$

Notes,

* K must be positive since it is the sum of two squares.

* $y = Cx^2$ is a family of parabolas.

* $y^2 + \frac{x^2}{2} = K$ is a family of ellipses.

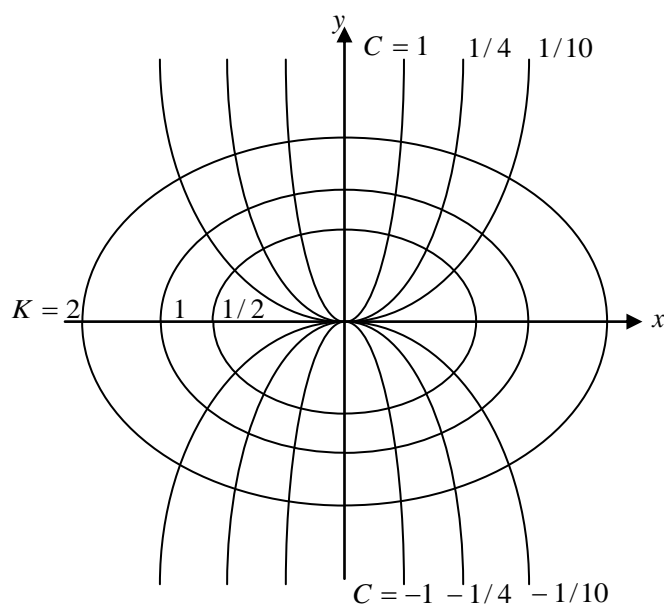

Example 2: Find the orthogonal trajectories of $xy = C$.

Solution:

Step 1; Find the slope of the given set,

$$\text{By differentiation } xdy + ydx = 0 \Rightarrow \left(\frac{dy}{dx}\right)_1 = \frac{-y}{x}.$$

Step 2; Find the slope of the required set,

$$\left(\frac{dy}{dx}\right)_2 = -1/\left(\frac{dy}{dx}\right)_1 \Rightarrow \left(\frac{dy}{dx}\right)_2 = -1/\left(\frac{-y}{x}\right) \Rightarrow \left(\frac{dy}{dx}\right)_2 = \frac{x}{y}.$$

Step 3; Find the required set,

$$\frac{dy}{dx} = \frac{x}{y} \quad (\text{separable variables DE}) \Rightarrow ydy = x.dx,$$

$$\therefore \frac{y^2}{2} = \frac{x^2}{2} + K_1 \quad \text{or} \quad y^2 - x^2 = K. \quad [K = 2K_1]$$

2- Suspended Cables

Example 1: Derive the differential equation of the curve of a perfectly flexible cable, of uniform weight per unit length w , suspended between two points.

Solution:

Start from the lowest point C and consider a cable segment of length x from point C ,

$$\sum F_y = 0 \Rightarrow T \sin \theta = w.s \quad \dots\dots (1)$$

$$\sum F_x = 0 \Rightarrow T \cos \theta = H \quad \dots\dots (2)$$

Dividing Eq. (1) by (2), gives

$$\tan \theta = \frac{w.s}{H}. \quad \text{But } \tan \theta = \frac{dy}{dx},$$

$$\therefore \frac{dy}{dx} = \frac{w.s}{H}.$$

Differentiating the last equation with respect to x , yields

$$\frac{d^2y}{dx^2} = \frac{w}{H} \cdot \frac{ds}{dx}.$$

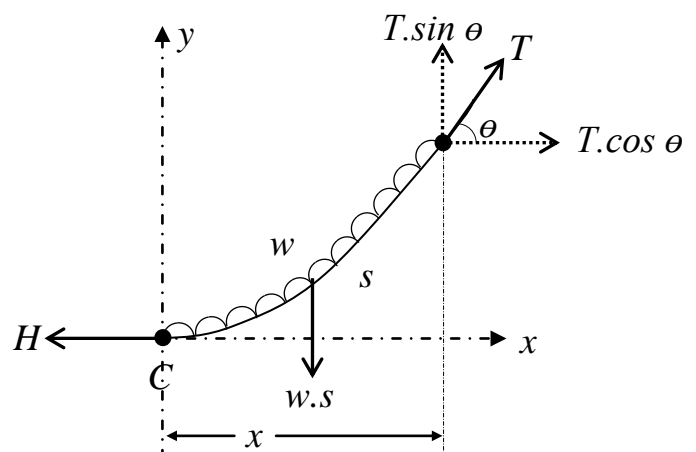
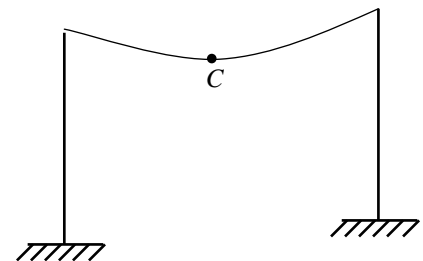

But $ds = \sqrt{(dx)^2 + (dy)^2}$ or $\frac{ds}{dx} = \sqrt{1 + \left(\frac{dy}{dx}\right)^2}$,

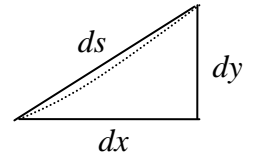

$\therefore \frac{d^2y}{dx^2} = \frac{w}{H} \cdot \sqrt{1 + \left(\frac{dy}{dx}\right)^2}$. (2nd order reducible to 1st order DE)

Since y does not appear in the above DE, then this equation can be reduced to a first order DE by letting

$$z = f(x) = \frac{dy}{dx} \quad \Rightarrow \quad \frac{dz}{dx} = \frac{d^2y}{dx^2}$$

$$\therefore \frac{dz}{dx} = \frac{w}{H} \cdot \sqrt{1 + z^2} \quad (\text{Separable DE}) \quad \Rightarrow \quad \frac{dz}{\sqrt{1 + z^2}} = \frac{w}{H} \cdot dx,$$

$$\Rightarrow \quad \sinh^{-1} z = \frac{w}{H} \cdot x + C_1 \quad \Rightarrow \quad z = \sinh\left(\frac{w}{H} \cdot x + C_1\right).$$

But $z = \frac{dy}{dx} \quad \Rightarrow \quad \frac{dy}{dx} = \sinh\left(\frac{w}{H} \cdot x + C_1\right),$

$$\therefore y = \frac{H}{w} \cosh\left(\frac{w}{H} \cdot x + C_1\right) + C_2. \quad (\text{G.S})$$

Applying the boundary conditions (B.C);

1- At the lowest point; $y'(0) = 0 \quad \Rightarrow \quad 0 = \sinh(0 + C_1) \quad \Rightarrow \quad C_1 = 0.$

2- At the lowest point; $y(0) = 0 \quad \Rightarrow \quad 0 = \frac{H}{w} \cosh(0) + C_2 \quad \Rightarrow \quad C_2 = -\frac{H}{w}.$

$$\therefore y = \frac{H}{w} \cosh\left(\frac{w}{H} \cdot x + 0\right) - \frac{H}{w} \quad \Rightarrow \quad y = \frac{H}{w} \left(\cosh\frac{wx}{H} - 1\right). \quad (\text{P.S})$$

Example 2: A suspended cable is hung between two points, of the same level, and is subjected to a horizontal uniformly distributed load, attached to the cable by vertical hangers, as shown in the figure. What is the shape of the cable at equilibrium? and how does the tension vary along the cable? (Neglect self weight of the cable).

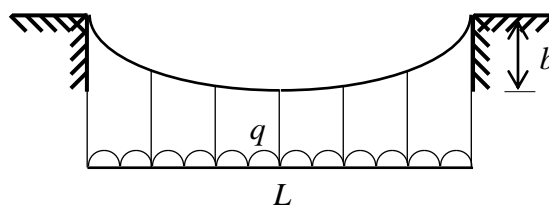

Solution:

Start from the lowest point C (at midspan due to symmetry) and consider a cable segment of length x from point C ,

$$\sum F_y = 0 \Rightarrow T \sin \theta = q \cdot x \quad \dots\dots (1)$$

$$\sum F_x = 0 \Rightarrow T \cos \theta = H \quad \dots\dots (2)$$

Dividing Eq. (1) by (2), gives

$$\tan \theta = \frac{q \cdot x}{H}. \quad \text{But } \tan \theta = \frac{dy}{dx},$$

$$\therefore \frac{dy}{dx} = \frac{q \cdot x}{H} \Rightarrow y = \frac{qx^2}{2H} + C. \quad \text{(G.S)}$$

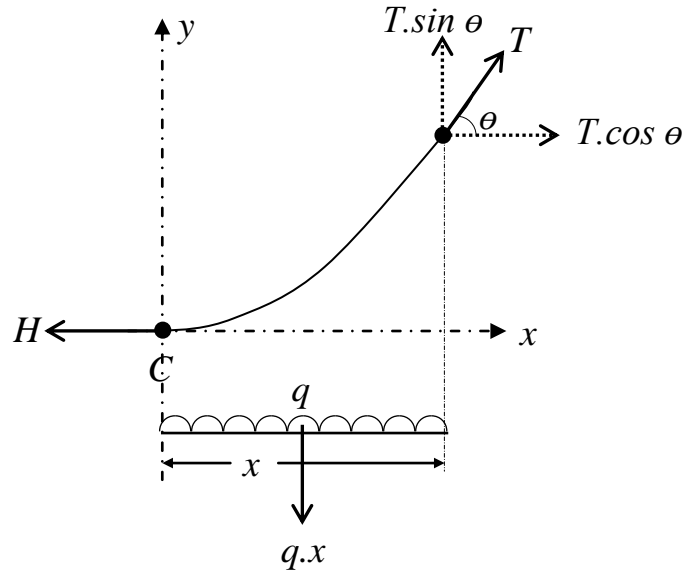

Boundary conditions (B.C);

$$1- \text{ At the lowest point; } y(0) = 0 \Rightarrow 0 = \frac{q(0)^2}{2H} + C \Rightarrow C = 0 \Rightarrow y = \frac{qx^2}{2H}.$$

$$2- \text{ At the right support; } y(L/2) = b \Rightarrow b = \frac{q(L/2)^2}{2H} \Rightarrow H = \frac{qL^2}{8b}.$$

$$\therefore y = \frac{qx^2}{2(qL^2/8b)} \Rightarrow y = \frac{4bx^2}{L^2}. \quad \text{(P.S)}$$

Consider the tension in the cable:

$$\text{At any point along the cable } T = \sqrt{T_x^2 + T_y^2} \Rightarrow T = \sqrt{(T \cdot \cos \theta)^2 + (T \cdot \sin \theta)^2},$$

$$\Rightarrow T = \sqrt{(H)^2 + (q \cdot x)^2} \Rightarrow T = \sqrt{H^2 + q^2 \cdot x^2}.$$

Thus, the tension is minimum when $x=0$ (i.e, at the lowest point where it is equal to H) and it increases towards the ends.

Note;

If we consider the self weight of the cable, then

$$\sum F_y = 0 \Rightarrow T \sin \theta = q \cdot x + w \cdot s \quad \dots\dots\dots (1)$$

$$\sum F_x = 0 \Rightarrow T \cos \theta = H \quad \dots\dots\dots (2)$$

Dividing Eq. (1) by (2), gives

$$\tan \theta = \frac{q \cdot x + w \cdot s}{H}. \quad \text{But } \tan \theta = \frac{dy}{dx} \Rightarrow \frac{dy}{dx} = \frac{q \cdot x + w \cdot s}{H}.$$

Differentiating the last equation with respect to x , yields

$$\frac{d^2y}{dx^2} = \frac{q}{H} + \frac{w}{H} \cdot \frac{ds}{dx}. \quad \text{But } ds = \sqrt{(dx)^2 + (dy)^2} \quad \text{or} \quad \frac{ds}{dx} = \sqrt{1 + \left(\frac{dy}{dx}\right)^2},$$

$$\frac{d^2y}{dx^2} = \frac{q}{H} + \frac{w}{H} \cdot \sqrt{1 + \left(\frac{dy}{dx}\right)^2}.$$

The above resulted DE is so difficult to be solved analytically.

3- Flow through orifices

Consider a tank which contains any liquid and there is an orifice (hole) at its bottom through which the liquid drains under the influence of gravity. Thus, the depth of water is changed through time. In an interval of time dt , the water level will fall by the amount dy , and the change of volume of liquid inside the tank is equal to the volume of liquid drained outside the tank, i.e.,

$$(dV)_{in} = (dV)_{out} \quad \Rightarrow \quad A \cdot dy = -Q \cdot dt,$$

where,

A is the cross sectional area of the tank.

Q is the discharge of liquid through the orifice $= C_d \cdot a \cdot v$.

C_d is the coefficient of discharge.

a is the area of the orifice (hole).

v is the velocity of liquid leaving the orifice $= \sqrt{2gy}$.

($-ve$) the negative sign indicates that as t increases, y decreases.

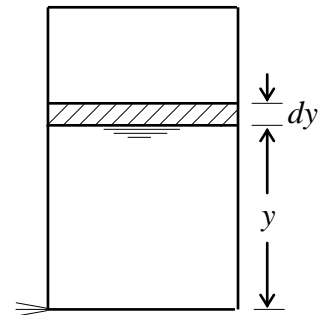

Example 1: An inverted right circular conical tank, as shown in the figure, is initially filled with water. The water drains, due to gravity, through a small hole of radius r at the bottom. Find the height of water as a function of time and the time required for the tank to drain completely.

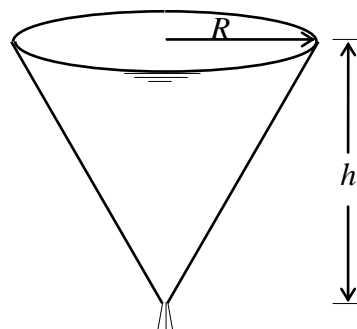

Solution:

$$\begin{aligned} (dV)_{in} &= (dV)_{out} \Rightarrow A.dy = -Q.dt, \\ \Rightarrow A.dy &= -C_d.a.v.dt, \\ \Rightarrow \pi x^2 .dy &= -C_d .\pi r^2 .\sqrt{2gy}.dt, \\ \Rightarrow x^2 .dy &= -C_d r^2 \sqrt{2gy}.dt. \end{aligned}$$

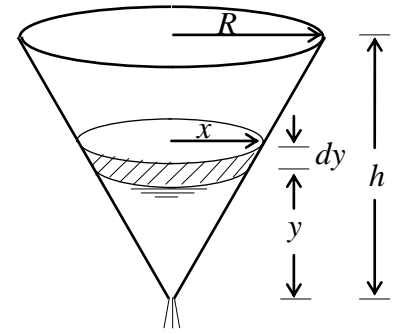

But $x = \frac{Ry}{h} \Rightarrow \frac{R^2 y^2}{h^2} .dy = -C_d r^2 \sqrt{2g} .\sqrt{y}.dt.$ (Separable variables DE)

$$\begin{aligned} \therefore \frac{y^2}{\sqrt{y}} .dy &= -\frac{C_d r^2 h^2 \sqrt{2g}}{R^2} .dt, \\ \Rightarrow y^{3/2} .dy &= -\frac{C_d r^2 h^2 \sqrt{2g}}{R^2} .dt, \\ \Rightarrow \frac{2}{5} y^{5/2} &= -\frac{C_d r^2 h^2 \sqrt{2g}}{R^2} .t + C. \quad \text{(G.S)} \end{aligned}$$

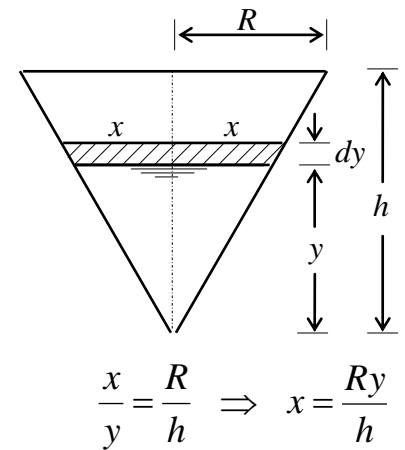

Applying the initial condition (I.C);

Initially, at $t = 0$, the tank is filled with water, $y = h$,

$$\therefore y(0) = h \Rightarrow \frac{2}{5} h^{5/2} = 0 + C \Rightarrow C = \frac{2}{5} h^{5/2}.$$

$$\therefore \frac{2}{5} y^{5/2} = -\frac{C_d r^2 h^2 \sqrt{2g}}{R^2} .t + \frac{2}{5} h^{5/2} \quad \text{or} \quad y^{5/2} = -\frac{5C_d r^2 h^2 \sqrt{2g}}{2R^2} .t + h^{5/2}. \quad \text{(P.S)}$$

The tank will be empty when $y = 0$,

$$\therefore 0 = -\frac{5C_d r^2 h^2 \sqrt{2g}}{2R^2} .t + h^{5/2} \Rightarrow t = \frac{2R^2 h^{5/2}}{5C_d r^2 h^2 \sqrt{2g}},$$

$$\text{or} \quad t = \frac{2}{5C_d} \cdot \left(\frac{R}{r}\right)^2 \cdot \sqrt{\frac{h}{2g}}.$$

Example 2: A water tank, rectangular in cross section, has the dimensions $20 \times 12m$ at the top and $6 \times 10m$ at the bottom and is $3m$ in height. It is filled with water and has a circular orifice of $5cm$ diameter at its bottom. Assuming $C_d = 0.6$ for the orifice, find the equation of the height of water in the tank with time, then compute the time required for emptying the tank.

Solution:

$$(dV)_{in} = (dV)_{out} \Rightarrow A.dy = -Q.dt,$$

$$\Rightarrow A.dy = -C_d.a.v.dt,$$

$$\Rightarrow x.z.dy = -C_d.\pi r^2.\sqrt{2gy}.dt,$$

$$(2y + 6)\left(\frac{10}{3}y + 10\right)dy = -0.6\pi\left(\frac{2.5}{100}\right)^2\sqrt{2 \times 9.81y}.dt,$$

$$\Rightarrow 20\left(\frac{y^2}{3} + 2y + 3\right)dy = -5.218 \times 10^{-3}\sqrt{y}.dt,$$

(Separable variables DE)

$$\therefore \left(\frac{y^2}{3\sqrt{y}} + \frac{2y}{\sqrt{y}} + \frac{3}{\sqrt{y}}\right)dy = -2.61 \times 10^{-4} dt,$$

$$\Rightarrow \left(\frac{1}{3}y^{3/2} + 2y^{1/2} + 3y^{-1/2}\right)dy = -2.61 \times 10^{-4} dt,$$

$$\therefore \frac{2}{15}y^{5/2} + \frac{4}{3}y^{3/2} + 6y^{1/2} = -2.61 \times 10^{-4}.t + C. \quad (\text{G.S})$$

Applying the initial condition (I.C);

Initially, at $t = 0$, the tank is filled with water, $y = 3m$,

$$\therefore y(0) = 3 \Rightarrow \frac{2}{15} \times 3^{5/2} + \frac{4}{3} \times 3^{3/2} + 6 \times 3^{1/2} = 0 + C,$$

$$\Rightarrow C = 19.4.$$

$$\therefore \frac{2}{15}y^{5/2} + \frac{4}{3}y^{3/2} + 6y^{1/2} = -2.61 \times 10^{-4}.t + 19.4. \quad (\text{P.S})$$

The tank will be empty when $y = 0$,

$$\therefore 0 = -2.61 \times 10^{-4}.t + 19.4,$$

$$\Rightarrow t = 74329.5 \text{ sec}$$

$$\approx 20.65 \text{ hr}$$

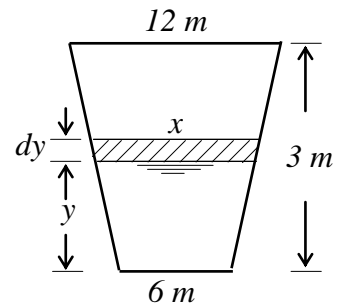
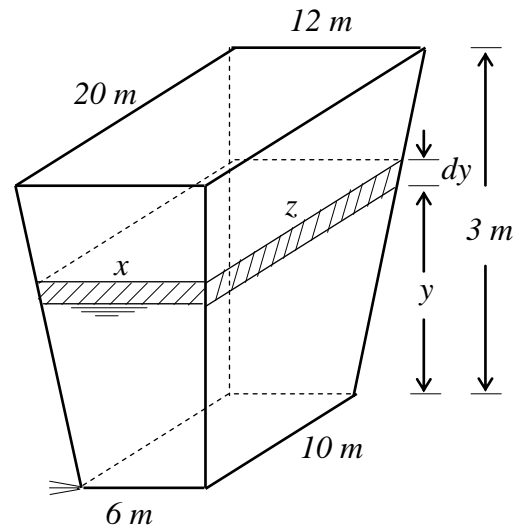

$$\frac{x - 6}{y} = \frac{12 - 6}{3}$$

$$\therefore x = 2y + 6$$

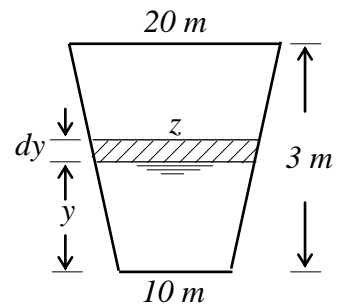

$$\frac{z - 10}{y} = \frac{20 - 10}{3}$$

$$\therefore z = \frac{10}{3}y + 10$$

Useful expressions,

$$A = x.L.$$

$$\frac{x}{b} = \frac{h-y}{h},$$

$$\therefore x = \frac{b}{h} \cdot (h-y).$$

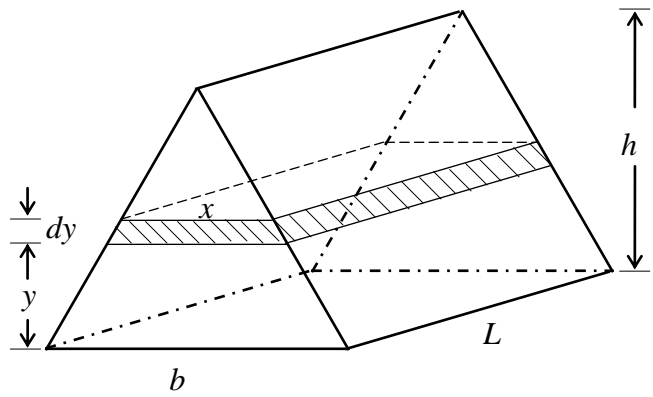

$$A = \pi x^2.$$

$$x^2 + (y-R)^2 = R^2,$$

$$\therefore x^2 = 2Ry - y^2.$$

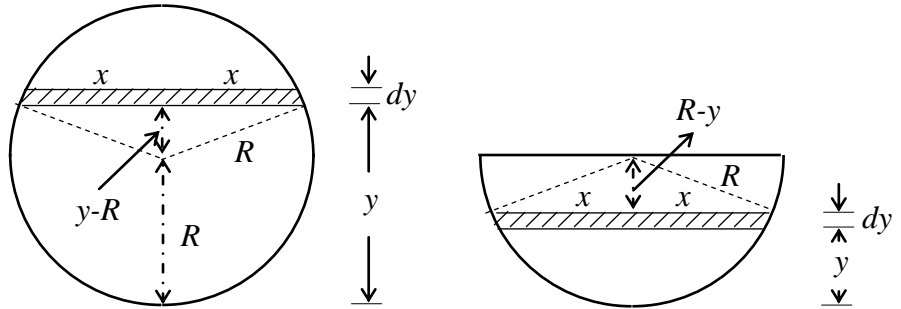

$$A = 2x.L.$$

$$x^2 + y^2 = R^2,$$

$$\therefore x = \sqrt{R^2 - y^2}.$$

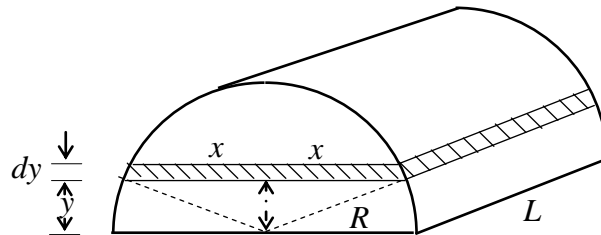

4- Motion of bodies

Example: A body, of mass m , falls from rest. If the drag (resisting) force of air is assumed to be proportional to the instantaneous velocity of the body, find the equation of motion of this body.

Solution:

Since the drag force D is proportional to the instantaneous velocity v ,

$$\therefore D \propto v \Rightarrow D = R.v. \quad (R \text{ is the proportion constant})$$

$$\sum F_y = m.a \Rightarrow w - D = m.a \Rightarrow m.g - R.v = m.a,$$

$$\Rightarrow m.g - R \cdot \frac{dy}{dt} = m \cdot \frac{d^2y}{dt^2} \Rightarrow \frac{d^2y}{dt^2} + \frac{R}{m} \cdot \frac{dy}{dt} = g. \quad (\text{reducible to 1}^{\text{st}} \text{ order DE})$$

Since y does not appear in the above DE, then this equation can be reduced to a first

order DE by letting $v = f(t) = \frac{dy}{dt} \Rightarrow \frac{dv}{dt} = \frac{d^2y}{dt^2}.$

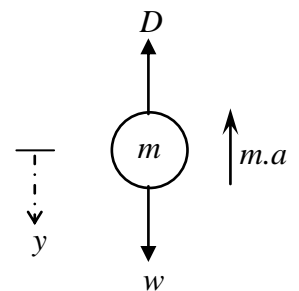

$$\therefore \frac{dv}{dt} + \frac{R}{m} \cdot v = g \quad (\text{Linear DE}) \Rightarrow \mu = e^{\int P(t)dt} \Rightarrow \mu = e^{\int \frac{R}{m} dt} = e^{Rt/m}.$$

$$\mu \cdot v = \int \mu \cdot Q(t) \cdot dt + C \Rightarrow e^{Rt/m} \cdot v = \int e^{Rt/m} \cdot g \cdot dt + C_1,$$

$$\Rightarrow v e^{Rt/m} = \frac{mg}{R} e^{Rt/m} + C_1 \Rightarrow v = \frac{mg}{R} + C_1 e^{-Rt/m}.$$

But $v = \frac{dy}{dt} \Rightarrow \frac{dy}{dt} = \frac{mg}{R} + C_1 e^{-Rt/m},$

$$\therefore y = \frac{mg}{R} \cdot t - \frac{mC_1}{R} \cdot e^{-Rt/m} + C_2. \quad (\text{G.S})$$

Initial conditions (I.C);

$$1- v(0) = y'(0) = 0 \Rightarrow 0 = \frac{mg}{R} + C_1 e^0 \Rightarrow C_1 = \frac{-mg}{R}.$$

$$2- y(0) = 0 \Rightarrow 0 = 0 - \frac{mC_1}{R} \cdot e^0 + C_2 \Rightarrow C_2 = \frac{mC_1}{R} \Rightarrow C_2 = \frac{-m^2g}{R^2}.$$

$$\therefore y = \frac{mg}{R} \cdot t - \frac{m}{R} \cdot \frac{-mg}{R} \cdot e^{-Rt/m} + \frac{-m^2g}{R^2},$$

or $y = \frac{mg}{R} \cdot t - \frac{m^2g}{R^2} (1 - e^{-Rt/m}). \quad (\text{P.S})$

5- General Applications

Example: the population growth (P) at any time in a city is governed by the equation

$\frac{dP}{dt} = (B - D \cdot P)P$, where B and D are the birth and death rate, respectively. If

$B = 0.1$, $D = 1 \times 10^{-7}$ (t is in year), and $P_0 = 5000$ person, find P as a function of time.

What is the limiting (maximum) value of population? At what time will be the population equal to one half of the limiting value?

Solution:

$$\frac{dP}{dt} = (B - D \cdot P)P \Rightarrow \frac{dP}{dt} - BP = -DP^2. \quad (\text{Bernoulli's equation})$$

Division by P^2 gives $P^{-2} \cdot \frac{dP}{dt} - BP^{-1} = -D.$

Let $z = P^{-1} \Rightarrow \frac{dz}{dt} = -P^{-2} \frac{dP}{dt} \Rightarrow P^{-2} \frac{dP}{dt} = -\frac{dz}{dt},$

$$\therefore -\frac{dz}{dt} - B.z = -D \Rightarrow \frac{dz}{dt} + B.z = D, \quad (\text{Linear DE with respect to } z)$$

$$\mu = e^{\int B dt} = e^{Bt}.$$

$$\mu.z = \int \mu.Q dt + C \Rightarrow e^{Bt}.z = \int e^{Bt}.D dt + C_1,$$

$$\Rightarrow z.e^{Bt} = \frac{D}{B}.e^{Bt} + C_1 \Rightarrow z = \frac{D}{B} + \frac{C_1}{e^{Bt}},$$

$$\text{but } z = P^{-1} = \frac{1}{P} \Rightarrow \frac{1}{P} = \frac{D}{B} + \frac{C_1}{e^{Bt}} \Rightarrow \frac{1}{P} = \frac{De^{Bt} + C_1 B}{Be^{Bt}},$$

$$\Rightarrow P = \frac{Be^{Bt}}{De^{Bt} + C_1 B} \quad [C = C_1 B] \quad \text{or} \quad P = \frac{B}{D + Ce^{-Bt}}. \quad (\text{G.S})$$

Initial conditions (I.C);

$$\text{At } t=0, \quad P=5000 \Rightarrow 5000 = \frac{0.1}{1 \times 10^{-7} + Ce^{-0.1(0)}},$$

$$\Rightarrow C = \frac{0.1}{5000} - 1 \times 10^{-7} = 2 \times 10^{-5}.$$

$$\therefore P = \frac{0.1}{1 \times 10^{-7} + 2 \times 10^{-5} e^{-0.1t}} \quad \text{or} \quad P = \frac{1000000}{1 + 200e^{-0.1t}}. \quad (\text{P.S})$$

Max. population P_{\max} occurs after a long period of time (i.e when $t \rightarrow \infty$),

$$\therefore P_{\max} = \frac{1000000}{1 + 200e^{-0.1(\infty)}} \Rightarrow P_{\max} = \frac{1000000}{1 + 200 \times 0} = 1000000.$$

$$(\text{Note; } e^{-0.1(\infty)} = e^{-\infty} = \frac{1}{e^{\infty}} = \frac{1}{\infty} \approx 0)$$

$$\text{When } P = \frac{1}{2} P_{\max} \Rightarrow P = \frac{1}{2} \times 1000000 = 500000 \text{ Person,}$$

$$\therefore 500000 = \frac{1000000}{1 + 200e^{-0.1t}} \Rightarrow 1 + 200e^{-0.1t} = \frac{1000000}{500000},$$

$$\Rightarrow e^{-0.1t} = \frac{2-1}{200} \Rightarrow -0.1t = \ln(5 \times 10^{-3}) \Rightarrow -0.1t \approx -5.3,$$

$$\therefore t \approx 53 \text{ year.}$$

4- Second and Higher Order Linear Ordinary Differential Equations

Introduction

The general form of linear DE of order n may be written as:

$$a_n \frac{d^n y}{dx^n} + a_{n-1} \frac{d^{n-1} y}{dx^{n-1}} + \dots + a_1 \frac{dy}{dx} + a_0 y = g(x), \quad (a_n \neq 0) \quad \dots \dots \dots (1)$$

where;

a_n, a_{n-1}, \dots, a_0 are called the coefficients for the DE and they are, in general, as functions of x ,

$g(x)$ is a function of x .

* If the coefficients a_n, a_{n-1}, \dots, a_0 are constants, then Eq.(1) is called linear DE with constant coefficients and if they are functions of x , then Eq.(1) is called linear DE with variable coefficients.

* If $g(x) = 0$, then Eq.(1) is called homogeneous linear DE, and if $g(x) \neq 0$, then Eq.(1) is called non-homogeneous linear DE.

Differential operator (D-operator)

A second standard form of Eq.(1) is based on the following notations:

$$\frac{dy}{dx} = Dy, \quad \frac{d^2 y}{dx^2} = D^2 y, \quad \text{in general} \quad \frac{d^n y}{dx^n} = D^n y,$$

where D is called the differential operator.

Thus, Eq.(1) can now be written as:

$$a_n D^n y + a_{n-1} D^{n-1} y + \dots + a_1 Dy + a_0 y = g(x),$$

or $(a_n D^n + a_{n-1} D^{n-1} + \dots + a_1 D + a_0) y = g(x).$

Superposition principle

Let y_1, y_2, \dots, y_n be solutions of a linear DE of order n , then the linear combination:

$$y = C_1 y_1 + C_2 y_2 + \dots + C_k y_k, \quad k \leq n$$

is also a solution, where C_1, C_2, \dots, C_k are arbitrary constants.

Linear dependence and independence

A set of n functions y_1, y_2, \dots, y_n is said to be linearly dependent if there exist n constants C_1, C_2, \dots, C_n (not all zero) such that:

$$C_1 y_1 + C_2 y_2 + \dots + C_n y_n = 0, \quad \text{or} \quad \sum_{i=1}^n C_i y_i = 0.$$

If no such constants can be found (i.e. do not exist), then the set of functions is said to be linearly independent. For example:

* For the functions $y_1 = 3e^{2x}$, $y_2 = 2e^{2x}$, and $y_3 = e^{-x}$,

if we put $C_1 = 2$, $C_2 = -3$, and $C_3 = 0$, then

$$C_1 y_1 + C_2 y_2 + C_3 y_3 = 2(3e^{2x}) + (-3)(2e^{2x}) + (0)(e^{-x}) = 0.$$

Thus, y_1 , y_2 , and y_3 are linearly dependent.

* For the functions $y_1 = e^{-x}$, $y_2 = e^x$, and $y_3 = e^{3x}$,

$$C_1 y_1 + C_2 y_2 + C_3 y_3 = C_1 e^{-x} + C_2 e^x + C_3 e^{3x} \neq 0.$$

Thus, y_1 , y_2 , and y_3 are linearly independent.

Wronskian determinants

It is not always easy to check the linear dependence of a given set of functions by searching for the value of the constants C_i which make $\sum_{i=1}^n C_i y_i = 0$. For this purpose, Wronskian determinant may be used as an alternative method.

Let y_1, y_2, \dots, y_n are given functions to be checked for linear dependence, then the Wronskian determinant is defined as,

$$w(y_1, y_2, \dots, y_n) = \begin{vmatrix} y_1 & y_2 & \cdot & \cdot & y_n \\ y_1' & y_2' & \cdot & \cdot & y_n' \\ \cdot & \cdot & \cdot & \cdot & \cdot \\ \cdot & \cdot & \cdot & \cdot & \cdot \\ y_1^{n-1} & y_2^{n-1} & \cdot & \cdot & y_n^{n-1} \end{vmatrix}.$$

If $w(y_1, y_2, \dots, y_n) = 0$, then y_1, y_2, \dots, y_n are linearly dependent.

If $w(y_1, y_2, \dots, y_n) \neq 0$, then y_1, y_2, \dots, y_n are linearly independent.

For example, the Wronskian determinant for the functions $y_1 = 2x^2$ and $y_2 = -3x^3$ is,

$$w(y_1, y_2) = \begin{vmatrix} y_1 & y_2 \\ y_1' & y_2' \end{vmatrix} = \begin{vmatrix} 2x^2 & -3x^3 \\ 4x & -9x^2 \end{vmatrix} = [(2x^2) \cdot (-9x^2)] - [(-3x^3) \cdot (4x)] = -6x^4.$$

Since $w(y_1, y_2) \neq 0$, then y_1 and y_2 are linearly independent.

General solution of homogeneous linear DE

The general solution (complete solution) of any homogeneous linear DE of n^{th} order will be the linear combination of n linearly independent solutions (y_1, y_2, \dots, y_n) for which $w(y_1, y_2, \dots, y_n) \neq 0$. Each linearly independent solution contains one constant, therefore the general solution will be contain n constants.

Solution of homogeneous linear DE with constant coefficients

A second order homogeneous linear DE with constant coefficients can be written as:

$$a \cdot \frac{d^2 y}{dx^2} + b \cdot \frac{dy}{dx} + c \cdot y = 0 \quad \text{or} \quad (a \cdot D^2 + b \cdot D + c)y = 0.$$

Let the solution is $y = e^{mx} \Rightarrow y' = me^{mx} \Rightarrow y'' = m^2 e^{mx}$,

Substituting in the DE gives:

$$a \cdot (m^2 e^{mx}) + b \cdot (me^{mx}) + c \cdot (e^{mx}) = 0 \Rightarrow e^{mx}(am^2 + b \cdot m + c) = 0,$$

but $e^{mx} \neq 0 \Rightarrow \therefore am^2 + b \cdot m + c = 0$. (Auxiliary or characteristic equation)

In practice it is obtained not by substituting $y = e^{mx}$ into the given DE and then simplifying, but rather by equating to zero the operational coefficient of y and then letting the symbol D plays the role of m , i.e. $a.D^2 + b.D + c = 0$.

$$\therefore m_{1,2} = \frac{-b \pm \sqrt{b^2 - 4ac}}{2a}.$$

The roots m_i may be:

1- Real and unequal roots when $(b^2 - 4ac > 0)$,

$$m_1 \neq m_2$$

$$\therefore y_1 = e^{m_1 x} \quad \text{and} \quad y_2 = e^{m_2 x}$$

$$y = C_1 y_1 + C_2 y_2 \quad \Rightarrow \quad y = C_1 e^{m_1 x} + C_2 e^{m_2 x}.$$

2- Real and equal roots when $(b^2 - 4ac = 0)$,

$$m_1 = m_2 = m = -\frac{b}{2a}$$

$$\therefore y_1 = y_2 = e^{mx},$$

$$y = C_1 e^{mx} + C_2 e^{mx} = C e^{mx}.$$

This could not be total solution because the DE is of the 2nd order and there must be two constants of integration. Thus, the solution $y = C e^{mx}$ is considered as a part of the solution and the total solution will be assumed as,

$$y = u(x).y_1, \quad \text{where} \quad y_1 = e^{mx}.$$

$$y' = u.y_1' + y_1.u',$$

$$y'' = u.y_1'' + y_1'.u' + y_1.u'' + u'.y_1' = u.y_1'' + 2u'.y_1' + u''.y_1$$

Substituting in the DE gives

$$a(u.y_1'' + 2u'.y_1' + u''.y_1) + b(u.y_1' + u'.y_1) + c(u.y_1) = 0,$$

$$(ay_1'' + by_1' + cy_1)u + (2ay_1' + by_1)u' + ay_1 u'' = 0.$$

But, $ay_1'' + by_1' + cy_1 = 0$, (since y_1 is a solution)

$$\text{and } 2ay_1' + by_1 = 2a\left(\frac{-b}{2a}e^{\frac{-b}{2a}x}\right) + b\left(e^{\frac{-b}{2a}x}\right) = 0,$$

$$\therefore ay_1 u'' = 0. \quad \text{But, } a \neq 0 \text{ and } y_1 \neq 0,$$

$$\therefore u'' = 0 \Rightarrow u' = C_1 \Rightarrow u = C_1 x + C_2.$$

$$\therefore y = u \cdot y_1 = (C_1 x + C_2)e^{mx}.$$

3- Complex roots when $(b^2 - 4ac < 0)$,

$$m_{1,2} = -\frac{b}{2a} \pm \left(\frac{1}{2a}\sqrt{4ac - b^2}\right)i = \alpha \pm \beta i,$$

$$\therefore y_1 = e^{(\alpha + \beta i)x} \quad \text{and} \quad y_2 = e^{(\alpha - \beta i)x},$$

$$\therefore y = Ae^{(\alpha + \beta i)x} + Be^{(\alpha - \beta i)x} \Rightarrow y = e^{\alpha x} (Ae^{\beta i x} + Be^{-\beta i x}).$$

$$\text{But, } e^{\pm \beta i x} = \cos \beta x \pm (\sin \beta x)i, \quad (\text{Euler formula})$$

$$\therefore y = e^{\alpha x} [A\{\cos \beta x + (\sin \beta x)i\} + B\{\cos \beta x - (\sin \beta x)i\}],$$

$$\Rightarrow y = e^{\alpha x} [(A + B)\cos \beta x + (A - B)(\sin \beta x)i],$$

$$\Rightarrow y = e^{\alpha x} (C_1 \cos \beta x + C_2 \sin \beta x).$$

Example 1: Solve $y'' - 3y' + 2y = 0$.

Solution :

$$\text{Using D-operator gives } D^2 y - 3Dy + 2y = 0 \quad \text{or} \quad (D^2 - 3D + 2)y = 0,$$

$$\therefore m^2 - 3m + 2 = 0, \quad (\text{Auxiliary or characteristic equation})$$

$$(m - 1)(m - 2) = 0 \Rightarrow \text{Either } m - 1 = 0 \Rightarrow m_1 = 1,$$

$$\text{or } m - 2 = 0 \Rightarrow m_2 = 2,$$

$$\therefore y_1 = e^{m_1 x} = e^x \quad \text{and} \quad y_2 = e^{m_2 x} = e^{2x},$$

$$y = C_1 y_1 + C_2 y_2 \Rightarrow y = C_1 e^x + C_2 e^{2x}. \quad (\text{G.S})$$

Example 2: Solve $\frac{d^2y}{dx^2} + 6\frac{dy}{dx} + 9y = 0$.

Solution :

$$D^2y + 6Dy + 9y = 0 \quad \text{or} \quad (D^2 + 6D + 9)y = 0,$$

$$\therefore m^2 + 6m + 9 = 0, \quad (\text{Auxiliary equation})$$

$$(m + 3)(m + 3) = 0 \Rightarrow m_1 = m_2 = -3 \Rightarrow y_1 = y_2 = e^{-3x},$$

$$\therefore y = C_1 e^{-3x} + C_2 x e^{-3x} \quad \text{or} \quad y = (C_1 + C_2 x) e^{-3x}. \quad (\text{G.S})$$

Example 3: Solve $y'' - 4y' + 7y = 0$.

Solution :

$$(D^2 - 4D + 7)y = 0 \Rightarrow \therefore m^2 - 4m + 7 = 0, \quad (\text{Auxiliary equation})$$

$$m_{1,2} = \frac{-(-4) \pm \sqrt{(-4)^2 - 4(1)(7)}}{2(1)} = \frac{4 \pm \sqrt{-12}}{2},$$

$$= \frac{4 \pm \sqrt{12}i}{2} = 2 \pm \sqrt{3}i, \quad (\alpha = 2 \text{ and } \beta = \sqrt{3})$$

$$y = e^{\alpha x} (C_1 \cos \beta x + C_2 \sin \beta x) \Rightarrow y = e^{2x} (C_1 \cos \sqrt{3}x + C_2 \sin \sqrt{3}x). \quad (\text{G.S})$$

Example 4: Solve $2y''' - y'' + 36y' - 18y = 0$.

Solution :

$$(2D^3 - D^2 + 36D - 18)y = 0 \Rightarrow 2m^3 - m^2 + 36m - 18 = 0,$$

$$2m(m^2 + 18) - (m^2 + 18) = 0 \Rightarrow (m^2 + 18)(2m - 1) = 0,$$

$$\text{Either } 2m - 1 = 0 \Rightarrow m_1 = \frac{1}{2},$$

$$\text{or } m^2 + 18 = 0 \Rightarrow m^2 = -18 \Rightarrow m_{2,3} = \pm \sqrt{-18} = \pm \sqrt{18}i = \pm 3\sqrt{2}i,$$

$$\therefore y = C_1 e^{x/2} + e^{(0)x} (C_2 \cos 3\sqrt{2}x + C_3 \sin 3\sqrt{2}x),$$

$$\text{or } y = C_1 e^{x/2} + C_2 \cos 3\sqrt{2}x + C_3 \sin 3\sqrt{2}x. \quad (\text{G.S})$$

Example 5: Solve $y''' + 7y'' + 11y' + 5y = 0$.

Solution :

$$(D^3 + 7D^2 + 11D + 5)y = 0 \quad \Rightarrow \quad m^3 + 7m^2 + 11m + 5 = 0.$$

By trial & error, if $m = -1$, then $(-1)^3 + 7(-1)^2 + 11(-1) + 5 = 0$,

$\therefore m = -1$ is a root $\Rightarrow (m + 1)$ is a factor.

To find the other factor we use long division.

$$\therefore (m + 1)(m^2 + 6m + 5) = 0,$$

$$\Rightarrow (m + 1)(m + 1)(m + 5) = 0,$$

$$\therefore m_1 = -1, m_2 = -1, \text{ and } m_3 = -5,$$

$$\therefore y = C_1 e^{-x} + C_2 x e^{-x} + C_3 e^{-5x},$$

$$\text{or } y = (C_1 + C_2 x).e^{-x} + C_3 e^{-5x}. \quad (\text{G.S})$$

$ \begin{array}{r} m^2 + 6m + 5 \\ m + 1 \overline{) m^3 + 7m^2 + 11m + 5} \\ \underline{m^3 + m^2} \\ 6m^2 + 11m + 5 \\ \underline{6m^2 + 6m} \\ 5m + 5 \\ \underline{5m + 5} \\ 0 \end{array} $
--

Example 6: Solve $\frac{d^4 y}{dx^4} + 18\frac{d^2 y}{dx^2} + 81y = 0$.

Solution :

$$(D^4 + 18D^2 + 81)y = 0 \quad \Rightarrow \quad m^4 + 18m^2 + 81 = 0.$$

$$(m^2 + 9)(m^2 + 9) = 0 \quad \Rightarrow \quad \text{Either } m^2 + 9 = 0 \quad \Rightarrow \quad m_{1,2} = \pm\sqrt{-9} = \pm 3i,$$

$$\text{or } m^2 + 9 = 0 \quad \Rightarrow \quad m_{3,4} = \pm\sqrt{-9} = \pm 3i,$$

$$\therefore y = e^{(0)x}(C_1 \cos 3x + C_2 \sin 3x) + x e^{(0)x}(C_3 \cos 3x + C_4 \sin 3x),$$

$$\text{or } y = (C_1 + C_3 x)\cos 3x + (C_2 + C_4 x)\sin 3x. \quad (\text{G.S})$$

Example 7: Solve $\frac{d^4 y}{dx^4} + 4y = 0$.

Solution :

$$(D^4 + 4)y = 0 \quad \Rightarrow \quad m^4 + 4 = 0 \quad \Rightarrow \quad m^4 = -4 \quad \Rightarrow \quad m^2 = \pm\sqrt{-4} = \pm 2i.$$

$$\text{Either } m^2 = 2i \Rightarrow m_{1,2} = \pm\sqrt{2i} \Rightarrow m_{1,2} = \pm\sqrt{(1+i)^2} \Rightarrow m_{1,2} = \pm(1+i),$$

$$\text{or } m^2 = -2i \Rightarrow m_{3,4} = \pm\sqrt{-2i} \Rightarrow m_{3,4} = \pm\sqrt{(1-i)^2} \Rightarrow m_{3,4} = \pm(1-i).$$

We can rearrange the roots as: $m_{1,2} = 1 \pm i$ and $m_{3,4} = -1 \pm i$,

$$\therefore y = e^x (C_1 \cos x + C_2 \sin x) + e^{-x} (C_3 \cos x + C_4 \sin x). \quad (\text{G.S})$$

Note;

$$\pm ai = \left(\sqrt{\frac{a}{2}} \pm \sqrt{\frac{a}{2}i} \right)^2.$$

Example 8: Solve $\frac{d^5 z}{dt^5} - 4 \frac{d^3 z}{dt^3} = 0.$

Solution :

$$(D^5 - 4D^3)z = 0 \Rightarrow m^5 - 4m^3 = 0 \Rightarrow m^3(m^2 - 4) = 0,$$

$$\text{either } m^3 = 0 \Rightarrow m_{1,2,3} = 0,$$

$$\text{or } m^2 - 4 = 0 \Rightarrow m^2 = 4 \Rightarrow m_{4,5} = \pm 2,$$

$$\therefore z = C_1 e^{(0)t} + C_2 t e^{(0)t} + C_3 t^2 e^{(0)t} + C_4 e^{(2)t} + C_5 e^{(-2)t},$$

$$\text{or } z = C_1 + C_2 t + C_3 t^2 + C_4 e^{2t} + C_5 e^{-2t}. \quad (\text{G.S})$$

Solution of non-homogeneous linear DE with constant coefficients

To find the general solution (complete solution) of a given non-homogeneous linear DE, the following steps are followed:

- 1- We find a general solution for the corresponding homogeneous linear DE (i.e. we put $g(x) = 0$). This solution is called the homogeneous or complementary solution, usually denoted by y_c , which will contain n constants (where n is the order of the given DE).

2- We find a particular solution for the given nonhomogeneous linear DE. This solution is called the particular solution, usually denoted by y_p , which will be free from constants.

3- The complete solution will be:

$$y = y_c + y_p.$$

There are different methods to find the particular solution.

1- Undetermined coefficients method

In this method we assume a trial solution containing unknown constants which are to be determined by substitution in the given DE. The trial solution to be assumed in each case depends on the special form of $g(x)$.

$g(x)$	Assumed trial solution y_p
a	A
ax^n (n a positive integer)	$A_0 + A_1x + A_2x^2 + \dots + A_nx^n$
ae^{mx} (m either real or complex)	Ae^{mx}
$a\cos\alpha x$ or $a\sin\alpha x$	$A\cos\alpha x + B\sin\alpha x$
$a\cosh\alpha x$ or $a\sinh\alpha x$	$A\cosh\alpha x + B\sinh\alpha x$
$ax^n e^{mx}$	$(A_0 + A_1x + \dots + A_nx^n)e^{mx}$
$ax^n \cos\alpha x$ or $ax^n \sin\alpha x$	$(A_0 + A_1x + \dots + A_nx^n)\cos\alpha x$ $+ (B_0 + B_1x + \dots + B_nx^n)\sin\alpha x$
$ae^{mx} \cos\alpha x$ or $ae^{mx} \sin\alpha x$	$(A\cos\alpha x + B\sin\alpha x)e^{mx}$
$ax^n e^{mx} \cos\alpha x$ or $ax^n e^{mx} \sin\alpha x$	$[(A_0 + A_1x + \dots + A_nx^n)\cos\alpha x$ $+ (B_0 + B_1x + \dots + B_nx^n)\sin\alpha x]e^{mx}$

Note,

If any term of the assumed trial solution does appear in the complementary solution (linearly dependent), we must multiply the trial solution by the smallest positive integer power of x which is large enough so that none of the terms, which are then present, appear in the complementary solution.

Example 1: Solve $y'' + 2y' + 10y = 25x^2$.

Solution :

Step 1: Find the complementary solution y_c ,

$$(D^2 + 2D + 10)y = 0 \quad \Rightarrow \quad m^2 + 2m + 10 = 0,$$

$$m_{1,2} = \frac{-2 \pm \sqrt{2^2 - 4(1)(10)}}{2(1)} = \frac{-2 \pm \sqrt{-36}}{2} = \frac{-2 \pm 6i}{2} = -1 \pm 3i,$$

$$\therefore y_c = e^{-x}(C_1 \cos 3x + C_2 \sin 3x).$$

Step 2: Find the particular solution y_p ,

$$\text{Let } y_p = A_0 + A_1x + A_2x^2 \quad \Rightarrow \quad y'_p = A_1 + 2A_2x \quad \Rightarrow \quad y''_p = 2A_2,$$

Substituting y_p and its derivatives in the given DE, yields

$$2A_2 + 2(A_1 + 2A_2x) + 10(A_0 + A_1x + A_2x^2) = 25x^2,$$

$$(2A_2 + 2A_1 + 10A_0) + (4A_2 + 10A_1)x + (10A_2)x^2 = 25x^2$$

$$\therefore 10A_2x^2 = 25x^2 \quad \Rightarrow \quad 10A_2 = 25 \quad \Rightarrow \quad A_2 = \frac{5}{2},$$

$$(4A_2 + 10A_1)x = 0 \quad \Rightarrow \quad 4A_2 + 10A_1 = 0 \quad \Rightarrow \quad A_1 = -\frac{4A_2}{10} = -\frac{4}{10} \times \frac{5}{2} = -1,$$

$$2A_2 + 2A_1 + 10A_0 = 0 \quad \Rightarrow \quad A_0 = \frac{-2A_2 - 2A_1}{10} = \frac{-2\left(\frac{5}{2}\right) - 2(-1)}{10} = -\frac{3}{10}.$$

$$\therefore y_p = -\frac{3}{10} - x + \frac{5}{2}x^2.$$

Step 3: Find the complete solution y ,

$$y = y_c + y_p \quad \Rightarrow \quad y = e^{-x}(C_1 \cos 3x + C_2 \sin 3x) - \frac{3}{10} - x + \frac{5}{2}x^2. \quad (\text{G.S})$$

Example 2: Solve $y'' - 2y' - 3y = 5\cos 2x - 9$.

Solution :

To find the complementary solution y_c ,

$$(D^2 - 2D - 3)y = 0 \quad \Rightarrow \quad \therefore m^2 - 2m - 3 = 0,$$

$$(m+1)(m-3) = 0 \quad \Rightarrow \quad m_1 = -1 \quad \text{and} \quad m_2 = 3,$$

$$\therefore y_c = C_1 e^{-x} + C_2 e^{3x}.$$

To find the particular solution y_p ,

$$\text{Let } y_p = A \cos 2x + B \sin 2x + C \quad \Rightarrow \quad y'_p = -2A \sin 2x + 2B \cos 2x,$$

$$\Rightarrow \quad y''_p = -4A \cos 2x - 4B \sin 2x,$$

Substituting,

$$\begin{aligned} (-4A \cos 2x - 4B \sin 2x) - 2(-2A \sin 2x + 2B \cos 2x) - 3(A \cos 2x + B \sin 2x + C) &= 5 \cos 2x - 9 \\ (-7A - 4B) \cos 2x + (4A - 7B) \sin 2x - 3C &= 5 \cos 2x - 9, \end{aligned}$$

$$\therefore (-7A - 4B) \cos 2x = 5 \cos 2x \quad \Rightarrow \quad -7A - 4B = 5 \dots (1),$$

$$(4A - 7B) \sin 2x = 0 \quad \Rightarrow \quad 4A - 7B = 0 \dots (2) \quad \Rightarrow \quad A = -\frac{7}{13} \text{ \& } B = -\frac{4}{13}.$$

$$-3C = -9 \quad \Rightarrow \quad C = 3.$$

$$\therefore y_p = -\frac{7}{13} \cos 2x - \frac{4}{13} \sin 2x + 3$$

To find the complete solution y ,

$$y = y_c + y_p \quad \Rightarrow \quad y = C_1 e^{-x} + C_2 e^{3x} - \frac{7}{13} \cos 2x - \frac{4}{13} \sin 2x + 3. \quad (\text{G.S})$$

Example 3: Solve $y'' + 2y' + y = e^x \sin x$.

Solution :

$$(D^2 + 2D + 1)y = 0 \quad \Rightarrow \quad m^2 + 2m + 1 = 0,$$

$$(m+1)(m+1) = 0 \quad \Rightarrow \quad m_1 = m_2 = -1,$$

$$\therefore y_c = C_1 e^{-x} + C_2 x e^{-x} \quad \text{or} \quad y_c = (C_1 + C_2 x) e^{-x}.$$

$$\text{Let } y_p = (A \cos x + B \sin x) e^x,$$

$$y'_p = (A \cos x + B \sin x) e^x + (-A \sin x + B \cos x) e^x,$$

$$= (A + B) e^x \cos x + (B - A) e^x \sin x,$$

$$y''_p = (A + B)(-e^x \sin x + e^x \cos x) + (B - A)(e^x \cos x + e^x \sin x),$$

$$= 2B e^x \cos x - 2A e^x \sin x$$

Substituting,

$$(2Be^x \cos x - 2Ae^x \sin x) + 2[(A+B)e^x \cos x + (B-A)e^x \sin x] + (A \cos x + B \sin x)e^x = e^x \sin x$$

$$(4B + 3A)e^x \cos x + (-4A + 3B)e^x \sin x = e^x \sin x,$$

$$\therefore (4B + 3A)e^x \cos x = 0 \Rightarrow 4B + 3A = 0 \dots(1),$$

$$(-4A + 3B)e^x \sin x = e^x \sin x \Rightarrow 3B - 4A = 1 \dots(2) \Rightarrow A = -\frac{4}{25} \text{ \& } B = \frac{3}{25}$$

$$\therefore y_p = \left(-\frac{4}{25} \cos x + \frac{3}{25} \sin x\right)e^x.$$

$$y = y_c + y_p \Rightarrow y = (C_1 + C_2 x)e^{-x} + \left(-\frac{4}{25} \cos x + \frac{3}{25} \sin x\right)e^x. \quad (\text{G.S})$$

Example 4: Solve $(D^3 - 5D^2 - 2D + 24)y = xe^{3x}$.

Solution :

$$m^3 - 5m^2 - 2m + 24 = 0,$$

By trial & error, if $m = -2$, then $(-2)^3 - 5(-2)^2 - 2(-2) + 24 = 0$,

$$\therefore m = -2 \text{ is a root } \Rightarrow (m + 2) \text{ is a factor.}$$

Use long division to find the other factor,

$$\therefore (m + 2)(m^2 - 7m + 12) = 0,$$

$$\Rightarrow (m + 2)(m - 3)(m - 4) = 0,$$

$$\Rightarrow m_1 = -2, m_2 = 3, \text{ and } m_3 = 4,$$

$$\therefore y_c = C_1 e^{-2x} + C_2 e^{3x} + C_3 e^{4x}.$$

Let $y_p = (A_0 + A_1 x)e^{3x} \cdot x = (A_0 x + A_1 x^2)e^{3x}$,

$$y'_p = 3(A_0 x + A_1 x^2)e^{3x} + (A_0 + 2A_1 x)e^{3x},$$

$$= [A_0 + (3A_0 + 2A_1)x + 3A_1 x^2]e^{3x},$$

$$y''_p = 3[A_0 + (3A_0 + 2A_1)x + 3A_1 x^2]e^{3x} + [3A_0 + 2A_1 + 6A_1 x]e^{3x},$$

$$= [(6A_0 + 2A_1) + (9A_0 + 12A_1)x + 9A_1 x^2]e^{3x},$$

$$y'''_p = 3[(6A_0 + 2A_1) + (9A_0 + 12A_1)x + 9A_1 x^2]e^{3x} + (9A_0 + 12A_1 + 18A_1 x)e^{3x},$$

$$= [(27A_0 + 18A_1) + (27A_0 + 54A_1)x + 27A_1 x^2]e^{3x}$$

Substituting,

$ \begin{array}{r} m^2 - 7m + 12 \\ m + 2 \overline{) m^3 - 5m^2 - 2m + 24} \\ \underline{m^3 + 2m^2} \\ -7m^2 - 2m + 24 \\ \underline{-7m^2 - 14m} \\ 12m + 24 \\ \underline{12m + 24} \\ 0 \end{array} $

$$[(27A_o + 18A_1) + (27A_o + 54A_1)x + 27A_1x^2]e^{3x} - 5[(6A_o + 2A_1) + (9A_o + 12A_1)x + 9A_1x^2]e^{3x} - 2[A_o + (3A_o + 2A_1)x + 3A_1x^2]e^{3x} + 24(xA_o + A_1x^2)e^{3x} = xe^{3x},$$

$$[(-5A_o + 8A_1) + (-10A_1)x]e^{3x} = xe^{3x},$$

$$\therefore -10A_1xe^{3x} = xe^{3x} \Rightarrow -10A_1 = 1 \Rightarrow A_1 = -\frac{1}{10},$$

$$-5A_o + 8A_1 = 0 \Rightarrow A_o = \frac{-8A_1}{-5} = \frac{8}{5} \times \frac{-1}{10} = -\frac{4}{25}$$

$$\therefore y_p = \left(-\frac{4}{25}x - \frac{1}{10}x^2\right)e^{3x}.$$

$$y = y_c + y_p \Rightarrow y = C_1 e^{-2x} + C_2 e^{3x} + C_3 e^{4x} + \left(-\frac{4}{25}x - \frac{1}{10}x^2\right)e^{3x},$$

$$\text{or } y = C_1 e^{-2x} + \left(C_2 - \frac{4}{25}x - \frac{1}{10}x^2\right)e^{3x} + \frac{1}{10}x - \frac{1}{16}x^2 + C_3 e^{4x}. \quad (\text{G.S})$$

Example 5: Solve $y'' + y = x \sin x + \cos x$.

Solution :

$$(D^2 + 1)y = 0 \Rightarrow m^2 + 1 = 0 \Rightarrow m^2 = -1 \Rightarrow m_{1,2} = \pm i,$$

$$\therefore y_c = e^{(0)x}(C_1 \cos x + C_2 \sin x) = C_1 \cos x + C_2 \sin x.$$

$$\text{Let } y_p = [(A_o + A_1x)\cos x].x + [(B_o + B_1x)\sin x].x + \cancel{D_1 \cos x} + \cancel{D_2 \sin x},$$

$$= A_o x \cos x + B_o x \sin x + A_1 x^2 \cos x + B_1 x^2 \sin x,$$

$$y'_p = -A_o x \sin x + A_o \cos x + B_o x \cos x + B_o \sin x - A_1 x^2 \sin x + 2A_1 x \cos x + B_1 x^2 \cos x + 2B_1 x \sin x$$

$$= A_o \cos x + B_o \sin x + (2A_1 + B_o)x \cos x + (-A_o + 2B_1)x \sin x + B_1 x^2 \cos x - A_1 x^2 \sin x,$$

$$y''_p = -A_o \sin x + B_o \cos x - (2A_1 + B_o)x \sin x + (2A_1 + B_o)\cos x + (-A_o + 2B_1)x \cos x$$

$$+ (-A_o + 2B_1)\sin x - B_1 x^2 \sin x + 2B_1 x \cos x - A_1 x^2 \cos x - 2A_1 x \sin x,$$

$$= (2A_1 + 2B_o)\cos x + (-2A_o + 2B_1)\sin x + (-A_o + 4B_1)x \cos x + (-4A_1 - B_o)x \sin x - A_1 x^2 \cos x - B_1 x^2 \sin x$$

Substituting,

$$(2A_1 + 2B_o)\cos x + (-2A_o + 2B_1)\sin x + (-A_o + 4B_1)x \cos x + (-4A_1 - B_o)x \sin x - A_1 x^2 \cos x - B_1 x^2 \sin x$$

$$+ A_o x \cos x + B_o x \sin x + A_1 x^2 \cos x + B_1 x^2 \sin x = x \sin x + \cos x,$$

$$(2A_1 + 2B_o)\cos x + (-2A_o + 2B_1)\sin x + 4B_1 x \cos x - 4A_1 x \sin x = x \sin x + \cos x,$$

$$\therefore 4B_1 x \cos x = 0 \Rightarrow B_1 = 0,$$

$$\begin{aligned}
(-2A_o + 2B_1)\sin x = 0 &\Rightarrow A_o = B_1 \Rightarrow A_o = 0, \\
-4A_1x\sin x = x\sin x &\Rightarrow -4A_1 = 1 \Rightarrow A_1 = -\frac{1}{4}, \\
(2A_1 + 2B_o)\cos x = \cos x &\Rightarrow 2A_1 + 2B_o = 1 \Rightarrow B_o = \frac{1 - 2A_1}{2} = \frac{1 - 2(-1/4)}{2} = \frac{3}{4}, \\
\therefore y_p &= \frac{3}{4}x\sin x - \frac{1}{4}x^2\cos x. \\
y = y_c + y_p &\Rightarrow y = C_1\cos x + C_2\sin x + \frac{3}{4}x\sin x - \frac{1}{4}x^2\cos x. \quad (\text{G.S})
\end{aligned}$$

2- Variation of parameters method

In this method, the particular solution is assumed by replacing the arbitrary constants C_1, C_2, \dots, C_n , in the complementary solution, by functions of x , say

u_1, u_2, \dots, u_n to be determined later, that is

$$y_p = u_1 y_1 + u_2 y_2 + \dots + u_n y_n,$$

where n is the order of the non-homogeneous linear DE to be solved. Then, the assumed particular solution is substituted into the DE, and imposing conditions on the resulting equation leads to the following equations:

$$u_1' y_1 + u_2' y_2 + \dots + u_n' y_n = 0,$$

$$u_1' y_1' + u_2' y_2' + \dots + u_n' y_n' = 0,$$

.....

$$u_1' y_1^{n-1} + u_2' y_2^{n-1} + \dots + u_n' y_n^{n-1} = g(x),$$

or in matrix form:

$$\begin{bmatrix}
y_1 & y_2 & \cdot & \cdot & y_n \\
y_1' & y_2' & \cdot & \cdot & y_n' \\
\cdot & \cdot & \cdot & \cdot & \cdot \\
\cdot & \cdot & \cdot & \cdot & \cdot \\
y_1^{n-1} & y_2^{n-1} & \cdot & \cdot & y_n^{n-1}
\end{bmatrix}
\begin{bmatrix}
u_1' \\
u_2' \\
\cdot \\
\cdot \\
u_n'
\end{bmatrix}
=
\begin{bmatrix}
0 \\
0 \\
\cdot \\
\cdot \\
g(x)
\end{bmatrix}.$$

The individual derivatives u_1', u_2', \dots, u_n' are found by solving the above matrix, then

,by integration, the required functions u_1, u_2, \dots, u_n are determined.

Example 1: Solve $y'' - y = e^x$.

Solution :

$$(D^2 - 1)y = 0 \quad \Rightarrow \quad m^2 - 1 = 0 \quad \Rightarrow \quad m_{1,2} = \pm 1,$$

$$\therefore y_c = C_1 e^x + C_2 e^{-x}. \quad (y_1 = e^x \text{ and } y_2 = e^{-x})$$

Let $y_p = u_1 e^x + u_2 e^{-x}$.

$$\begin{bmatrix} y_1 & y_2 \\ y_1' & y_2' \end{bmatrix} \begin{bmatrix} u_1' \\ u_2' \end{bmatrix} = \begin{bmatrix} 0 \\ g(x) \end{bmatrix} \quad \Rightarrow \quad \begin{bmatrix} e^x & e^{-x} \\ e^x & -e^{-x} \end{bmatrix} \begin{bmatrix} u_1' \\ u_2' \end{bmatrix} = \begin{bmatrix} 0 \\ e^x \end{bmatrix}.$$

Using Cramer's rule to solve the above matrix, gives

$$u_1' = \frac{\begin{vmatrix} 0 & e^{-x} \\ e^x & -e^{-x} \end{vmatrix}}{\begin{vmatrix} e^x & e^{-x} \\ e^x & -e^{-x} \end{vmatrix}} \quad \Rightarrow \quad u_1' = \frac{(0)(-e^{-x}) - (e^{-x})(e^x)}{(e^x)(-e^{-x}) - (e^{-x})(e^x)} = \frac{-1}{-1-1} = \frac{-1}{-2} = \frac{1}{2},$$

$$\therefore u_1 = \int \frac{1}{2} dx = \frac{1}{2} x.$$

Similarly,

$$u_2' = \frac{\begin{vmatrix} e^x & 0 \\ e^x & e^x \end{vmatrix}}{\begin{vmatrix} e^x & e^{-x} \\ e^x & -e^{-x} \end{vmatrix}} \quad \Rightarrow \quad u_2' = \frac{(e^x)(e^x) - (0)(e^x)}{-2} = \frac{e^{2x}}{-2} = -\frac{1}{2} e^{2x},$$

$$\therefore u_2 = \int -\frac{1}{2} e^{2x} dx = -\frac{1}{4} e^{2x}.$$

$$\therefore y_p = \left(\frac{1}{2} x\right) e^x + \left(-\frac{1}{4} e^{2x}\right) e^{-x} = \frac{1}{2} x e^x - \frac{1}{4} e^x.$$

$$y = y_c + y_p,$$

$$y = C_1 e^x + C_2 e^{-x} + \frac{1}{2} x e^x - \frac{1}{4} e^x,$$

or $y = \left(C_1 - \frac{1}{4} + \frac{1}{2} x\right) e^x + C_2 e^{-x} = \left(C + \frac{1}{2} x\right) e^x + C_2 e^{-x}. \quad [C = C_1 - \frac{1}{4}] \quad (\text{G.S})$

Example 2: Solve $(D^2 + 1)y = \sec x$.

Solution :

$$m^2 + 1 = 0 \Rightarrow m^2 = -1 \Rightarrow m_{1,2} = \pm i, \quad (\alpha = 0 \text{ and } \beta = 1)$$

$$\therefore y_c = C_1 \cos x + C_2 \sin x. \quad (y_1 = \cos x \text{ and } y_2 = \sin x)$$

Let $y_p = u_1 \cos x + u_2 \sin x$.

$$\begin{bmatrix} y_1 & y_2 \\ y_1' & y_2' \end{bmatrix} \begin{Bmatrix} u_1' \\ u_2' \end{Bmatrix} = \begin{bmatrix} 0 \\ g(x) \end{bmatrix} \Rightarrow \begin{bmatrix} \cos x & \sin x \\ -\sin x & \cos x \end{bmatrix} \begin{Bmatrix} u_1' \\ u_2' \end{Bmatrix} = \begin{bmatrix} 0 \\ \sec x \end{bmatrix}.$$

Using Cramer's rule to solve the above matrix, gives

$$u_1' = \frac{\begin{vmatrix} 0 & \sin x \\ \sec x & \cos x \end{vmatrix}}{\begin{vmatrix} \cos x & \sin x \\ -\sin x & \cos x \end{vmatrix}},$$

$$\Rightarrow u_1' = \frac{(0)(\cos x) - (\sin x)(\sec x)}{(\cos x)(\cos x) - (\sin x)(-\sin x)} = \frac{-(\sin x)\left(\frac{1}{\cos x}\right)}{\cos^2 x + \sin^2 x} = \frac{-\frac{\sin x}{\cos x}}{1} = -\frac{\sin x}{\cos x},$$

$$\therefore u_1 = \int -\frac{\sin x}{\cos x} dx = \ln \cos x.$$

Similarly,

$$u_2' = \frac{\begin{vmatrix} \cos x & 0 \\ -\sin x & \sec x \end{vmatrix}}{\begin{vmatrix} \cos x & \sin x \\ -\sin x & \cos x \end{vmatrix}},$$

$$\Rightarrow u_2' = \frac{(\cos x)(\sec x) - (0)(-\sin x)}{1} = \frac{(\cos x)\left(\frac{1}{\cos x}\right)}{1} = 1,$$

$$\therefore u_2 = \int (1) dx = x.$$

$$\therefore y_p = (\ln \cos x) \cos x + (x) \sin x = \cos x \ln \cos x + x \sin x.$$

$$y = y_c + y_p,$$

$$y = C_1 \cos x + C_2 \sin x + \cos x \ln \cos x + x \sin x,$$

or $y = (C_1 + \ln \cos x) \cos x + (C_2 + x) \sin x. \quad (\text{G.S})$

Solution of some linear DE with variable coefficients

There are some important linear DE with variable coefficients which can be always reduced, by a suitable substitution, to linear DE with constant coefficients.

1- Euler-Cauchy equation

The general form of Euler-Cauchy equation is

$$a_n x^n \frac{d^n y}{dx^n} + a_{n-1} x^{n-1} \frac{d^{n-1} y}{dx^{n-1}} + \dots + a_1 x \frac{dy}{dx} + a_0 y = g(x),$$

where a_n, a_{n-1}, \dots, a_0 are constants.

For example, the DE $(x^3 y''' + 3x^2 y'' + xy' + 4y = \cos x)$ is an Euler-Cauchy equation. Euler-Cauchy equations can be always reduced to linear DE with constant coefficients by the suitable substitution: $z = \ln x$ or $x = e^z$.

Example 1: Solve $x^2 \frac{d^2 y}{dx^2} - 2y = x$.

Solution :

$$\text{Let } z = \ln x \quad (\text{i.e. } x = e^z) \quad \Rightarrow \quad \frac{dz}{dx} = \frac{1}{x},$$

$$\frac{dy}{dx} = \frac{dy}{dz} \cdot \frac{dz}{dx} = \frac{1}{x} \cdot \frac{dy}{dz},$$

$$\frac{d^2 y}{dx^2} = \frac{d}{dx} \left(\frac{1}{x} \cdot \frac{dy}{dz} \right) = \frac{1}{x} \left(\frac{d^2 y}{dz^2} \cdot \frac{dz}{dx} \right) + \frac{dy}{dz} \left(\frac{-1}{x^2} \right) = \frac{1}{x^2} \left(\frac{d^2 y}{dz^2} - \frac{dy}{dz} \right),$$

Substituting,

$$x^2 \left[\frac{1}{x^2} \left(\frac{d^2 y}{dz^2} - \frac{dy}{dz} \right) \right] - 2y = e^z,$$

$$\Rightarrow \frac{d^2 y}{dz^2} - \frac{dy}{dz} - 2y = e^z. \quad (\text{Non-homogeneous linear DE with constant coefficients})$$

$$(D^2 - D - 2)y = 0 \quad \Rightarrow \quad m^2 - m - 2 = 0,$$

$$(m+1)(m-2) = 0 \quad \Rightarrow \quad m_1 = -1 \quad \text{and} \quad m_2 = 2,$$

$$\therefore y_c = C_1 e^{-z} + C_2 e^{2z}.$$

$$\text{Let } y_p = Ae^z \Rightarrow y'_p = Ae^z = y''_p.$$

$$\text{Substituting, } Ae^z - Ae^z - 2Ae^z = e^z \Rightarrow -2Ae^z = e^z \Rightarrow A = -\frac{1}{2},$$

$$\therefore y_p = -\frac{1}{2}e^z.$$

$$y = y_c + y_p \Rightarrow y = C_1 e^{-z} + C_2 e^{2z} - \frac{1}{2}e^z.$$

$$\text{But } z = \ln x \Rightarrow y = C_1 e^{-\ln x} + C_2 e^{2\ln x} - \frac{1}{2}e^{\ln x},$$

$$\Rightarrow y = C_1 x^{-1} + C_2 x^2 - \frac{1}{2}x. \quad (\text{G.S})$$

Example 2: Solve $y''' + \frac{3}{x} \cdot y'' = \frac{6}{x}.$

Solution:

The given DE is linear DE with variable coefficients. Multiplying it by x^3 gives

$$x^3 y''' + 3x^2 y'' = 6x^2. \quad (\text{Euler-Cauchy equation})$$

$$\text{Let } z = \ln x \quad (\text{i.e. } x = e^z) \Rightarrow \frac{dz}{dx} = \frac{1}{x},$$

$$\frac{dy}{dx} = \frac{dy}{dz} \cdot \frac{dz}{dx} = \frac{1}{x} \cdot \frac{dy}{dz},$$

$$\frac{d^2 y}{dx^2} = \frac{d}{dx} \left(\frac{1}{x} \cdot \frac{dy}{dz} \right) = \frac{1}{x} \left(\frac{d^2 y}{dz^2} \cdot \frac{dz}{dx} \right) + \frac{dy}{dz} \left(\frac{-1}{x^2} \right) = \frac{1}{x^2} \left(\frac{d^2 y}{dz^2} - \frac{dy}{dz} \right),$$

$$\begin{aligned} \frac{d^3 y}{dx^3} &= \frac{d}{dx} \left[\frac{1}{x^2} \left(\frac{d^2 y}{dz^2} - \frac{dy}{dz} \right) \right] = \frac{1}{x^2} \left(\frac{d^3 y}{dz^3} \cdot \frac{dz}{dx} - \frac{d^2 y}{dz^2} \cdot \frac{dz}{dx} \right) + \left(\frac{d^2 y}{dz^2} - \frac{dy}{dz} \right) \left(\frac{-2}{x^3} \right) \\ &= \frac{1}{x^3} \left(\frac{d^3 y}{dz^3} - 3 \frac{d^2 y}{dz^2} + 2 \frac{dy}{dz} \right) \end{aligned}$$

Substituting,

$$x^3 \left[\frac{1}{x^3} \left(\frac{d^3 y}{dz^3} - 3 \frac{d^2 y}{dz^2} + 2 \frac{dy}{dz} \right) \right] + 3x^2 \left[\frac{1}{x^2} \left(\frac{d^2 y}{dz^2} - \frac{dy}{dz} \right) \right] = 6(e^z)^2,$$

$$\Rightarrow \frac{d^3 y}{dz^3} - \frac{dy}{dz} = 6e^{2z}. \text{ (Non-homogeneous linear DE with constant coefficients)}$$

$$(D^3 - D)y = 0 \Rightarrow m^3 - m = 0 \Rightarrow m(m^2 - 1) = 0 \Rightarrow m_1 = 0 \text{ and } m_{2,3} = \pm 1,$$

$$\therefore y_c = C_1 + C_2 e^z + C_3 e^{-z}.$$

$$\text{Let } y_p = Ae^{2z} \Rightarrow y'_p = 2Ae^{2z} \Rightarrow y''_p = 4Ae^{2z} \Rightarrow y'''_p = 8Ae^{2z}.$$

$$\text{Substituting, } 8Ae^{2z} - 2Ae^{2z} = 6e^{2z} \Rightarrow 6Ae^{2z} = 6e^{2z} \Rightarrow A = 1,$$

$$\therefore y_p = e^{2z}.$$

$$y = y_c + y_p \Rightarrow y = C_1 + C_2 e^z + C_3 e^{-z} + e^{2z}.$$

$$\text{But } z = \ln x \Rightarrow y = C_1 + C_2 e^{\ln x} + C_3 e^{-\ln x} + e^{2 \ln x},$$

$$\Rightarrow y = C_1 + C_2 x + C_3 x^{-1} + x^2. \quad \text{(G.S)}$$

2- Legender equation

The general form of Legender equation is,

$$a_n (Ax + B)^n \frac{d^n y}{dx^n} + a_{n-1} (Ax + B)^{n-1} \frac{d^{n-1} y}{dx^{n-1}} + \dots + a_1 (Ax + B) \frac{dy}{dx} + a_0 y = g(x),$$

where a_n, a_{n-1}, \dots, a_0 are constants.

For example, the DE $((2x + 1)^3 y''' + 2(2x + 1)y' + 4y = \ln x)$ is a Legender equation.

Legender equations can be always reduced to linear DE with constant coefficients by

the suitable substitution: $z = \ln(Ax + B)$ or $Ax + B = e^z$.

Example 1: Solve $(x - 2)^2 y'' + 2(x - 2)y' - 6y = 0$.

Solution :

$$\text{Let } z = \ln(x - 2) \quad (\text{i.e. } x - 2 = e^z) \Rightarrow \frac{dz}{dx} = \frac{1}{x - 2},$$

$$\frac{dy}{dx} = \frac{dy}{dz} \cdot \frac{dz}{dx} = \frac{1}{x - 2} \cdot \frac{dy}{dz},$$

$$\frac{d^2y}{dx^2} = \frac{d}{dx} \left(\frac{1}{x-2} \cdot \frac{dy}{dz} \right) = \frac{1}{x-2} \left(\frac{d^2y}{dz^2} \cdot \frac{dz}{dx} \right) + \frac{dy}{dz} \left(\frac{-1}{(x-2)^2} \right) = \frac{1}{(x-2)^2} \left(\frac{d^2y}{dz^2} - \frac{dy}{dz} \right),$$

Substituting,

$$(x-2)^2 \left[\frac{1}{(x-2)^2} \left(\frac{d^2y}{dz^2} - \frac{dy}{dz} \right) \right] + 2(x-2) \left[\frac{1}{x-2} \cdot \frac{dy}{dz} \right] - 6y = 0,$$

$$\Rightarrow \frac{d^2y}{dz^2} + \frac{dy}{dz} - 6y = 0. \quad (\text{Homogeneous linear DE with constant coefficients})$$

$$(D^2 + D - 6)y = 0 \quad \Rightarrow \quad m^2 + m - 6 = 0,$$

$$(m+3)(m-2) = 0 \quad \Rightarrow \quad m_1 = -3 \quad \text{and} \quad m_2 = 2,$$

$$\therefore y = C_1 e^{-3z} + C_2 e^{2z}.$$

But $z = \ln(x-2) \Rightarrow y = C_1 e^{-3\ln(x-2)} + C_2 e^{2\ln(x-2)},$

$$\Rightarrow y = C_1 (x-2)^{-3} + C_2 (x-2)^2. \quad (\text{G.S})$$

5- Applications on Second and Higher Order Linear ODE

1. Deflection of beams

Differential equations of deflected shapes:

$$EI \cdot \frac{d^2 y}{dx^2} = -M_x,$$

$$\therefore V = \frac{dM}{dx} \Rightarrow \therefore EI \cdot \frac{d^3 y}{dx^3} = -V_x,$$

$$\therefore w = -\frac{dV}{dx} \Rightarrow \therefore EI \cdot \frac{d^4 y}{dx^4} = w_x,$$

where;

y is the deflection, M_x , V_x , and w_x are the bending moment (B.M), shear force (S.F), and uniformly distributed load (U.D.L) at a section at distance x , respectively, and EI is the rigidity of the cross section of the beam.

The following boundary conditions are stated according to the supporting type,

* Hinge or pin or roller,

No deflection $\Rightarrow y(0) = 0.$

No bending moment $\Rightarrow y''(0) = 0.$

* Fixed or clamped,

No deflection $\Rightarrow y(0) = 0.$

No rotation $\Rightarrow y'(0) = 0.$

* Free end,

No bending moment $\Rightarrow y''(0) = 0.$

No shear force $\Rightarrow y'''(0) = 0.$

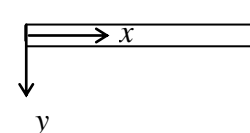
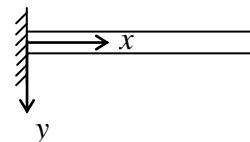
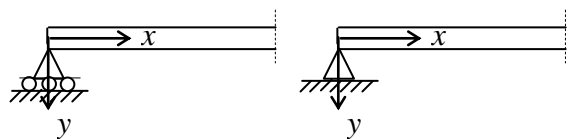
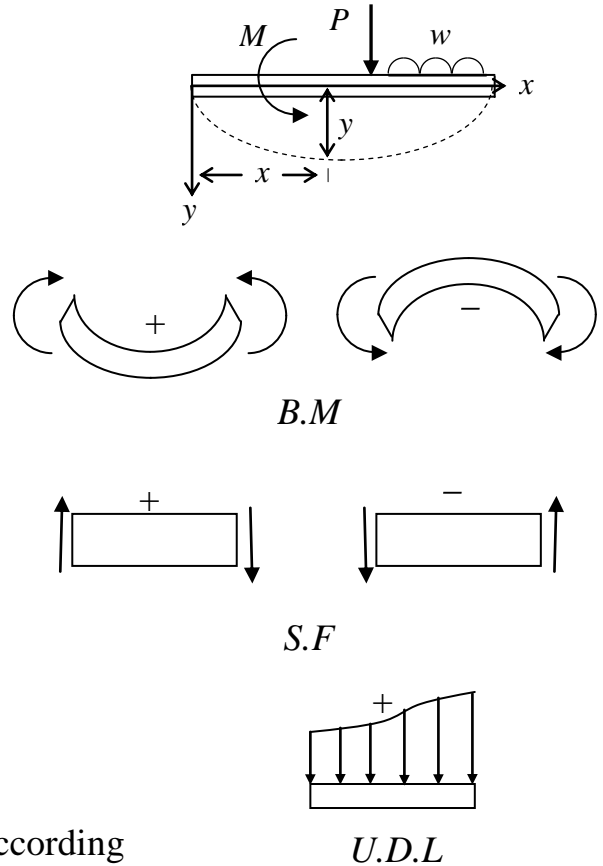

Example 1: A cantilever beam of length L is subjected to a concentrated load P at the free end. Derive and solve the differential equation of the deflection curve of the beam and also find the maximum deflection. (Neglect self weight)

Solution:

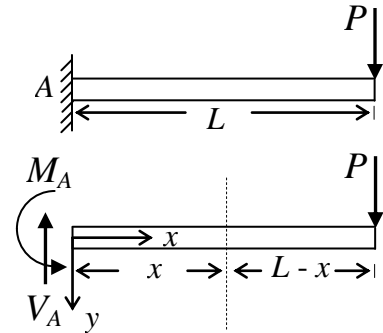

$$EI \cdot \frac{d^2 y}{dx^2} = -M_x.$$

$$M_x = -P(L - x),$$

$$\therefore EI \cdot \frac{d^2 y}{dx^2} = -[-P(L - x)],$$

or
$$\frac{d^2 y}{dx^2} = \frac{P}{EI} (L - x).$$

Method I,

Since the right side terms are functions of x only, we can solve the DE by integrating both sides directly,

$$\frac{dy}{dx} = \frac{P}{EI} \left(Lx - \frac{x^2}{2} \right) + C_1,$$

$$y = \frac{P}{EI} \left(\frac{Lx^2}{2} - \frac{x^3}{6} \right) + C_1 x + C_2. \quad (\text{G.S})$$

Method II,

We can solve the DE as a non-homogeneous linear DE,

$$D^2 y = 0 \quad \Rightarrow \quad m^2 = 0 \quad \Rightarrow \quad m_{1,2} = 0,$$

$$\therefore y_c = C_1 x + C_2.$$

Let
$$y_p = (A_0 + A_1 x)x^2 \quad \Rightarrow \quad y_p = A_0 x^2 + A_1 x^3,$$

$$y'_p = 2A_0 x + 3A_1 x^2 \quad \Rightarrow \quad y''_p = 2A_0 + 6A_1 x,$$

Substituting,

$$2A_0 + 6A_1 x = \frac{P}{EI} (L - x) \quad \Rightarrow \quad 2A_0 + 6A_1 x = \frac{PL}{EI} - \frac{Px}{EI},$$

To determine M_x :
 Either from left;
 $M_x = V_A \cdot x - M_A.$
 $\sum F_y = 0,$
 $P - V_A = 0 \Rightarrow V_A = P.$
 $\sum (M)_A = 0,$
 $M_A - P \cdot L = 0 \Rightarrow M_A = PL.$
 $\therefore M_x = P \cdot x - PL$
 $\qquad \qquad = -P(L - x).$
 Or from right;
 $M_x = -P(L - x).$

$$\therefore 2A_o = \frac{PL}{EI} \Rightarrow A_o = \frac{PL}{2EI},$$

$$6A_1 = -\frac{P}{EI} \Rightarrow A_1 = -\frac{P}{6EI},$$

$$\therefore y_p = \frac{PL}{2EI}x^2 - \frac{P}{6EI}x^3 = \frac{P}{EI}\left(\frac{Lx^2}{2} - \frac{x^3}{6}\right).$$

$$y = y_c + y_p \Rightarrow y = C_1x + C_2 + \frac{P}{EI}\left(\frac{Lx^2}{2} - \frac{x^3}{6}\right). \quad (\text{G.S})$$

Boundary conditions,

$$1- y(0) = 0 \Rightarrow 0 = 0 + C_2 + 0 \Rightarrow C_2 = 0.$$

$$2- y'(0) = 0, \quad y' = C_1 + \frac{P}{EI}\left(Lx - \frac{x^2}{2}\right) \Rightarrow 0 = C_1 + 0 \Rightarrow C_1 = 0.$$

$$\therefore y = \frac{P}{EI}\left(\frac{Lx^2}{2} - \frac{x^3}{6}\right) \quad \text{or} \quad y = \frac{Px^2}{6EI}(3L - x). \quad (\text{P.S})$$

Maximum deflection of cantilever beams occurs at the free end, that is at $x = L$,

$$y_{\max} = \frac{P(L)^2}{6EI}(3L - L) = \frac{PL^3}{3EI}.$$

Example 2: Find the deflection curve and the reactions for the beam shown below.

(Neglect self weight)

Solution:

$$EI \cdot \frac{d^4 y}{dx^4} = w_x. \quad \text{Here } w_x = w$$

$$\therefore EI \cdot \frac{d^4 y}{dx^4} = w \quad \text{or} \quad \frac{d^4 y}{dx^4} = \frac{w}{EI}.$$

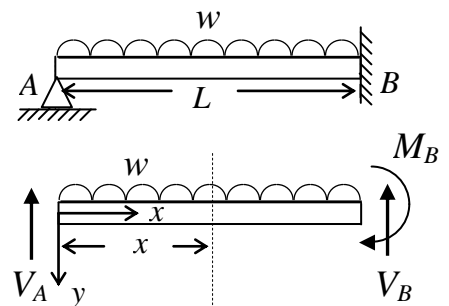

(Statically indeterminate)

Integrating both sides directly gives,

$$\frac{d^3 y}{dx^3} = \frac{wx}{EI} + C_1 \Rightarrow \frac{d^2 y}{dx^2} = \frac{wx^2}{2EI} + C_1x + C_2,$$

$$\frac{dy}{dx} = \frac{wx^3}{6EI} + \frac{C_1x^2}{2} + C_2x + C_3 \Rightarrow y = \frac{wx^4}{24EI} + \frac{C_1x^3}{6} + \frac{C_2x^2}{2} + C_3x + C_4. \quad (\text{G.S})$$

Boundary conditions,

$$1- y(0) = 0 \quad \Rightarrow \quad 0 = 0 + C_4 \quad \Rightarrow \quad C_4 = 0.$$

$$2- y''(0) = 0 \quad \Rightarrow \quad 0 = 0 + C_2 \quad \Rightarrow \quad C_2 = 0.$$

$$3- y(L) = 0 \quad \Rightarrow \quad 0 = \frac{wL^4}{24EI} + \frac{C_1 L^3}{6} + C_3 L. \quad \dots\dots (1)$$

$$4- y'(L) = 0 \quad \Rightarrow \quad 0 = \frac{wL^3}{6EI} + \frac{C_1 L^2}{2} + C_3. \quad \dots\dots (2)$$

Solving Eqs. (1) & (2) simultaneously yields,

$$C_1 = -\frac{3wL}{8EI} \quad \text{and} \quad C_3 = \frac{wL^3}{48EI}.$$

$$\therefore y = \frac{wx^4}{24EI} - \frac{wLx^3}{16EI} + \frac{wL^3x}{48EI}. \quad \text{(P.S)}$$

$$V_A = -EI(y''')_A = -EIy'''(0) = -EI\left(-\frac{3wL}{8EI}\right) = \frac{3wL}{8}. \quad (\uparrow)$$

$$V_B = -EI(y''')_B = -EIy'''(L) = -EI\left(\frac{wL}{EI} - \frac{3wL}{8EI}\right) = -\frac{5wL}{8}. \quad (\uparrow)$$

$$M_B = -EI(y'')_B = -EIy''(L) = -EI\left(\frac{wL^2}{2EI} - \frac{3wL^2}{8EI}\right) = -\frac{wL^2}{8}. \quad (\curvearrowright)$$

Note,

We can solve the above 4th order DE as a non-homogeneous linear DE, as follows

$$D^4 y = 0 \quad \Rightarrow \quad m^4 = 0 \quad \Rightarrow \quad m_{1,2,3,4} = 0,$$

$$\therefore y_c = C_1 + C_2 x + C_3 x^2 + C_4 x^3.$$

$$\text{Let } y_p = A_o(x^4) \quad \Rightarrow \quad y_p = A_o x^4,$$

$$y'_p = 4A_o x^3 \quad \Rightarrow \quad y''_p = 12A_o x^2 \quad \Rightarrow \quad y'''_p = 24A_o x \quad \Rightarrow \quad y^{iv}_p = 24A_o,$$

Substituting,

$$24A_o = \frac{w}{EI} \quad \Rightarrow \quad A_o = \frac{w}{24EI} \quad \Rightarrow \quad y_p = \frac{wx^4}{24EI}.$$

$$y = y_c + y_p \quad \Rightarrow \quad \therefore y = C_1 + C_2 x + C_3 x^2 + C_4 x^3 + \frac{wx^4}{24EI}. \quad \text{(G.S)}$$

2. Buckling of columns

Example 1: Determine the critical buckling load of a hinged-hinged column.

Solution:

Consider a column of length L , as shown in Fig.(a) or Fig.(b), hinged at both ends, and subjected to a compressive axial force P .

$$EI \cdot \frac{d^2 y}{dx^2} = -M_x. \quad \text{But } M_x = P \cdot y,$$

$$\therefore EI \cdot \frac{d^2 y}{dx^2} = -P \cdot y \Rightarrow \frac{d^2 y}{dx^2} + \frac{P}{EI} y = 0.$$

$$\text{Let } \beta^2 = \frac{P}{EI} \Rightarrow \frac{d^2 y}{dx^2} + \beta^2 y = 0,$$

$$\text{or } (D^2 + \beta^2)y = 0 \Rightarrow m^2 + \beta^2 = 0,$$

$$\Rightarrow m^2 = -\beta^2 \Rightarrow m_{1,2} = \pm \beta i,$$

$$\therefore y = C_1 \cos \beta x + C_2 \sin \beta x. \quad (\text{G.S})$$

Boundary conditions,

$$1. y(0) = 0 \Rightarrow 0 = C_1 + 0 \Rightarrow C_1 = 0.$$

$$\therefore y = C_2 \sin \beta x.$$

$$2. y(L) = 0 \Rightarrow 0 = C_2 \sin \beta L.$$

$$\text{If } C_2 = 0 \Rightarrow y = 0.$$

(i.e. the column remains straight)

$$\therefore C_2 \neq 0 \Rightarrow \sin \beta L = 0 \Rightarrow \beta L = 0, \pi, 2\pi, \dots, n\pi,$$

$$\therefore \beta L = n\pi \Rightarrow \beta = \frac{n\pi}{L}. \quad (n = 1, 2, 3, \dots)$$

$$\text{But } \beta^2 = \frac{P}{EI} \Rightarrow \frac{P}{EI} = \frac{n^2 \pi^2}{L^2} \Rightarrow P = \frac{n^2 \pi^2 EI}{L^2}.$$

$$\text{For } n = 1 \Rightarrow P_{cr} = \frac{\pi^2 EI}{L^2}, \quad (\text{Euler load or critical load})$$

$$\text{and } y = C_2 \sin \frac{\pi x}{L}. \quad (C_2 \text{ remains indeterminate, that is } y(\frac{L}{2}) = C_2)$$

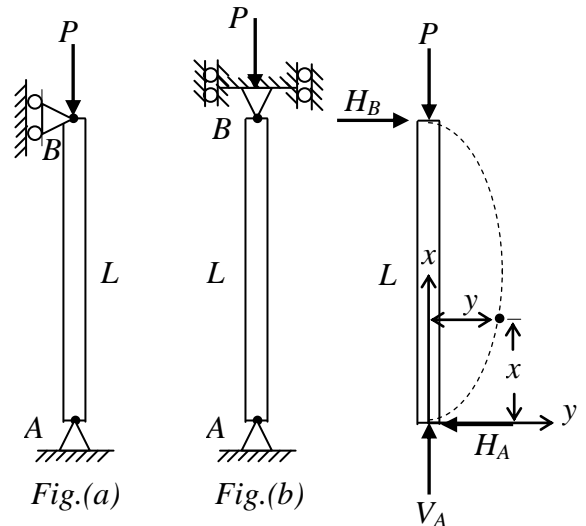

To determine M_x :

Either from down (left);

$$M_x = V_A \cdot y + H_A \cdot x.$$

$$\sum F_x = 0,$$

$$V_A - P = 0 \Rightarrow V_A = P.$$

$$\sum F_y = 0,$$

$$H_B - H_A = 0 \Rightarrow H_A = H_B.$$

$$\sum (M)_B = 0,$$

$$H_A \cdot L = 0 \Rightarrow H_A = 0,$$

$$\therefore H_B = 0.$$

$$\therefore M_x = P \cdot y.$$

Or from up (right);

$$M_x = P \cdot y - H_B \cdot (L - x)$$

$$= P \cdot y.$$

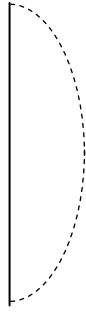

$$n = 1$$

$$P_{cr} = \frac{\pi^2 EI}{L^2}$$

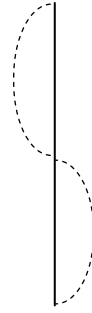

$$n = 2$$

$$P_{cr} = \frac{4\pi^2 EI}{L^2}$$



$$n = 3$$

$$P_{cr} = \frac{9\pi^2 EI}{L^2}$$

Critical buckling load: is the smallest value of axial load that can cause buckling.

* If $P < P_{cr}$, then the case is “*stable equilibrium*”. In this case, no buckling would occur. If lateral deflection is produced, by a horizontal force, then this deflection vanishes when the horizontal force is removed.

* If $P = P_{cr}$, then the case is “*neutral equilibrium*”. In this case, small and limited buckling may occur. If lateral deflection is produced, by a horizontal force, then this deflection remains constant even when the horizontal force is removed.

* If $P > P_{cr}$, then the case is “*unstable equilibrium*”. In this case, large not-controlled buckling may occur. If lateral deflection is produced, by a horizontal force, then this deflection will be increased, and if not controlled, the column will collapse.

Example 2: Determine the critical buckling load of a fixed-free column.

Solution:

Let the buckling at the free end is (d).

$$EI \frac{d^2 y}{dx^2} = -M_x. \quad \text{But} \quad M_x = -P(d - y),$$

$$\therefore EI \frac{d^2 y}{dx^2} = -[-P(d - y)] \Rightarrow \frac{d^2 y}{dx^2} + \frac{P}{EI} y = \frac{P}{EI} d.$$

$$\text{Let } \beta^2 = \frac{P}{EI} \Rightarrow \frac{d^2 y}{dx^2} + \beta^2 y = \beta^2 d,$$

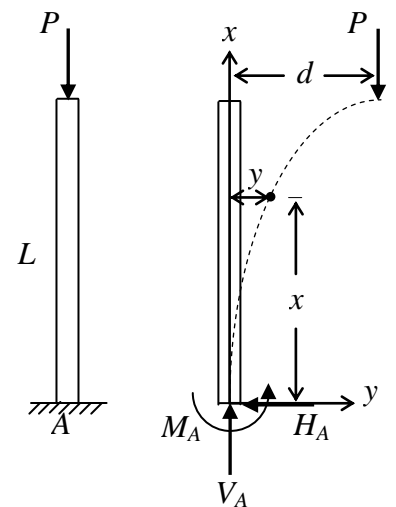

$$\text{or } (D^2 + \beta^2)y = \beta^2 d \Rightarrow m^2 + \beta^2 = 0,$$

$$\Rightarrow m^2 = -\beta^2 \Rightarrow m_{1,2} = \pm \beta i,$$

$$\therefore y_c = C_1 \cos \beta x + C_2 \sin \beta x.$$

$$\text{Let } y_p = A \Rightarrow y'_p = y''_p = 0.$$

Substituting,

$$0 + \beta^2 A = \beta^2 d \Rightarrow A = d \Rightarrow y_p = d.$$

$$y = y_c + y_p,$$

$$\therefore y = C_1 \cos \beta x + C_2 \sin \beta x + d. \quad (\text{G.S})$$

Boundary conditions,

$$1. y(0) = 0 \Rightarrow 0 = C_1 + d \Rightarrow C_1 = -d.$$

$$\therefore y = -d \cos \beta x + C_2 \sin \beta x + d.$$

$$2. y'(0) = 0, \quad y' = -\beta C_1 \sin \beta x + \beta C_2 \cos \beta x \Rightarrow 0 = 0 + \beta C_2 \Rightarrow C_2 = 0.$$

$$\therefore y = -d \cos \beta x + d \quad \text{or} \quad y = d(1 - \cos \beta x).$$

$$3. y(L) = d \Rightarrow d = d(1 - \cos \beta L) \Rightarrow 1 = 1 - \cos \beta L,$$

$$\Rightarrow \cos \beta L = 0 \Rightarrow \beta L = \frac{\pi}{2}, \frac{3\pi}{2}, \dots, \frac{(2n-1)\pi}{2},$$

$$\therefore \beta L = \frac{(2n-1)\pi}{2} \Rightarrow \beta = \frac{(2n-1)\pi}{2L}. \quad (n=1,2,3,\dots)$$

$$\text{But } \beta^2 = \frac{P}{EI} \Rightarrow \frac{P}{EI} = \frac{(2n-1)^2 \pi^2}{4L^2} \Rightarrow P_{cr} = \frac{(2n-1)^2 \pi^2 EI}{4L^2}.$$

$$\text{For } n=1 \Rightarrow P_{cr} = \frac{\pi^2 EI}{4L^2}. \quad (\text{i.e. } \frac{1}{4} \text{ times the critical load for hinged-hinged case})$$

To determine M_x :
 Either from up (right);
 $M_x = -P(d - y)$.
 Or from down (left);
 $M_x = V_A \cdot y + H_A \cdot x - M_A$.
 $\sum F_x = 0$,
 $V_A - P = 0 \Rightarrow V_A = P$.
 $\sum F_y = 0$,
 $-H_A = 0 \Rightarrow H_A = 0$.
 $\sum (M)_A = 0$,
 $M_A - Pd = 0 \Rightarrow M_A = Pd$.
 $\therefore M_x = Py - Pd$
 $= -P(d - y)$.

3. Deflection of beam-columns

Example 1: A simply supported beam-column of length L is subjected to a concentrated load Q at midspan and an axial compressive force P as shown in the figure below. Derive and solve the differential equation of the deflection curve. Then find the max. deflection and max. bending moment.

(Neglect self weight)

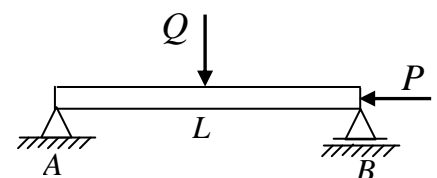

Solution:

$$EI \cdot \frac{d^2 y}{dx^2} = -M_x.$$

But $M_x = \frac{Q}{2}x + Py,$

$$\therefore EI \cdot \frac{d^2 y}{dx^2} = -\left[\frac{Q}{2}x + Py\right],$$

$$\Rightarrow \frac{d^2 y}{dx^2} + \frac{P}{EI}y = -\frac{Q}{2EI}x.$$

Let $\beta^2 = \frac{P}{EI} \Rightarrow \frac{d^2 y}{dx^2} + \beta^2 y = -\frac{Q}{2EI}x,$

or $(D^2 + \beta^2)y = -\frac{Q}{2EI}x \Rightarrow m^2 + \beta^2 = 0,$

$$\Rightarrow m^2 = -\beta^2 \Rightarrow m_{1,2} = \pm \beta i,$$

$$\therefore y_c = C_1 \cos \beta x + C_2 \sin \beta x.$$

Let $y_p = A_0 + A_1 x \Rightarrow y'_p = A_1 \Rightarrow y''_p = 0.$

Substituting,

$$0 + \beta^2(A_0 + A_1 x) = -\frac{Q}{2EI}x,$$

$$\therefore \beta^2 A_0 = 0 \Rightarrow A_0 = 0,$$

$$\beta^2 A_1 = -\frac{Q}{2EI} \Rightarrow A_1 = -\frac{Q}{2\beta^2 EI} = -\frac{Q}{2P},$$

$$\therefore y_p = -\frac{Q}{2P}x.$$

$$y = y_c + y_p \Rightarrow y = C_1 \cos \beta x + C_2 \sin \beta x - \frac{Q}{2P}x. \quad (0 \leq x \leq L/2) \quad (\text{G.S})$$

Boundary conditions,

1. $y(0) = 0 \Rightarrow 0 = C_1 + 0 \Rightarrow C_1 = 0.$

2. $y'(L/2) = 0, \quad y' = -\beta C_1 \sin \beta x + \beta C_2 \cos \beta x - \frac{Q}{2P},$

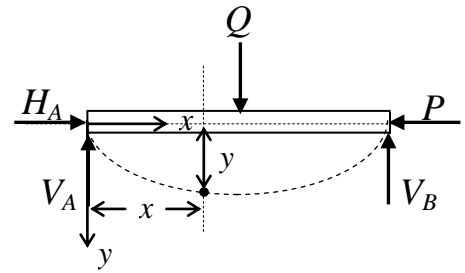

To determine M_x :

From left;

$$M_x = V_A \cdot x + H_A \cdot y. \quad (0 \leq x \leq L/2)$$

$$\sum F_x = 0,$$

$$H_A - P = 0 \Rightarrow H_A = P.$$

$$\sum (M)_B = 0,$$

$$Q \cdot \frac{L}{2} - V_A \cdot L = 0 \Rightarrow V_A = \frac{Q}{2}.$$

$$\therefore M_x = \frac{Q}{2}x + Py.$$

$$\Rightarrow 0 = 0 + \beta C_2 \cos \beta L/2 - \frac{Q}{2P} \Rightarrow C_2 = \frac{Q}{2P\beta \cos \beta L/2}.$$

$$\therefore y = \frac{Q}{2P\beta \cos \beta L/2} \sin \beta x - \frac{Q}{2P} x \quad \text{or} \quad y = \frac{Q}{2P} \left(\frac{\sin \beta x}{\beta \cos \beta L/2} - x \right). \quad (\text{P.S})$$

From symmetry, max. deflection occurs at midspan (i.e. at $x = L/2$),

$$\therefore y_{\max} = \frac{Q}{2P} \left(\frac{\sin \beta L/2}{\beta \cos \beta L/2} - \frac{L}{2} \right) = \frac{QL}{4P} \left(\frac{\tan \beta L/2}{\beta L/2} - 1 \right).$$

Since $M_x = \frac{Q}{2}x + Py$, thus max. B.M occurs at midspan (i.e. at $x = L/2$),

$$M_{\max} = \frac{Q}{2} \cdot \frac{L}{2} + Py_{\max} = \frac{QL}{4} + P \left[\frac{QL}{4P} \left(\frac{\tan \beta L/2}{\beta L/2} - 1 \right) \right] = \frac{Q \tan \beta L/2}{2\beta}.$$

Example 2: Find the deflection equation.

Solution:

$$EI \cdot \frac{d^2 y}{dx^2} = -M_x.$$

Let the deflection at the free end is (d).

$$M_x = -P(d - y) - \frac{w}{2}(L - x)^2,$$

$$\therefore EI \cdot \frac{d^2 y}{dx^2} = -[-P(d - y) - \frac{w}{2}(L - x)^2],$$

$$\Rightarrow \frac{d^2 y}{dx^2} + \frac{P}{EI} y = \frac{Pd}{EI} + \frac{w}{2EI}(L - x)^2.$$

$$\text{Let } \beta^2 = \frac{P}{EI} \Rightarrow \frac{d^2 y}{dx^2} + \beta^2 y = \beta^2 d + \frac{w}{2EI}(L - x)^2,$$

$$\text{or } (D^2 + \beta^2)y = \beta^2 d + \frac{w}{2EI}(L - x)^2,$$

$$\Rightarrow m^2 + \beta^2 = 0 \Rightarrow m^2 = -\beta^2 \Rightarrow m_{1,2} = \pm \beta i,$$

$$\therefore y_c = C_1 \cos \beta x + C_2 \sin \beta x.$$

$$\text{Let } y_p = A_0 + A_1 x + A_2 x^2 \Rightarrow y'_p = A_1 + 2A_2 x \Rightarrow y''_p = 2A_2.$$

Substituting,

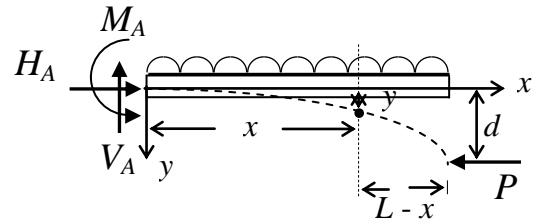
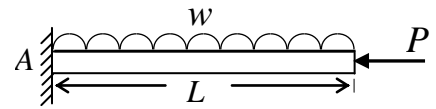

To determine M_x :

From right;

$$M_x = -P(d - y) - \frac{w}{2}(L - x)^2.$$

$$2A_2 + \beta^2(A_0 + A_1x + A_2x^2) = \beta^2d + \frac{w}{2EI}(L^2 - 2Lx + x^2),$$

$$\therefore \beta^2A_2 = \frac{w}{2EI} \Rightarrow A_2 = \frac{w}{2\beta^2EI} = \frac{w}{2P},$$

$$\beta^2A_1 = -\frac{wL}{EI} \Rightarrow A_1 = -\frac{wL}{\beta^2EI} = -\frac{wL}{P},$$

$$2A_2 + \beta^2A_0 = \beta^2d + \frac{wL^2}{2EI} \Rightarrow A_0 = d + \frac{wL^2}{2\beta^2EI} - \frac{2A_2}{\beta^2} \Rightarrow A_0 = d + \frac{wL^2}{2P} - \frac{w}{\beta^2P}.$$

$$\therefore y_p = d + \frac{wL^2}{2P} - \frac{w}{\beta^2P} - \frac{wLx}{P} + \frac{wx^2}{2P}$$

$$= d + \frac{w}{2P}(L^2 - 2Lx + x^2) - \frac{w}{\beta^2P} = d + \frac{w}{2P}(L-x)^2 - \frac{w}{\beta^2P}.$$

$$y = y_c + y_p \Rightarrow y = C_1 \cos \beta x + C_2 \sin \beta x + d + \frac{w}{2P}(L-x)^2 - \frac{w}{\beta^2P}. \quad (\text{G.S})$$

Boundary conditions,

$$1. y(0) = 0 \Rightarrow 0 = C_1 + 0 + d + \frac{wL^2}{2P} - \frac{w}{\beta^2P} \Rightarrow C_1 = -d - \frac{wL^2}{2P} + \frac{w}{\beta^2P}.$$

$$2. y'(0) = 0, \quad y' = -\beta C_1 \sin \beta x + \beta C_2 \cos \beta x - \frac{w}{P}(L-x),$$

$$\Rightarrow 0 = 0 + \beta C_2 - \frac{wL}{P} \Rightarrow C_2 = \frac{wL}{\beta P}.$$

$$\therefore y = \left(-d - \frac{wL^2}{2P} + \frac{w}{\beta^2P} \right) \cos \beta x + \left(\frac{wL}{\beta P} \right) \sin \beta x + d + \frac{w}{2P}(L-x)^2 - \frac{w}{\beta^2P}. \quad (\text{P.S})$$

To find the max. deflection (i.e. deflection at the free end):

$$y(L) = d \Rightarrow d = \left(-d - \frac{wL^2}{2P} + \frac{w}{\beta^2P} \right) \cos \beta L + \left(\frac{wL}{\beta P} \right) \sin \beta L + d + 0 - \frac{w}{\beta^2P},$$

$$\Rightarrow d \cos \beta L = \left(-\frac{wL^2}{2P} \right) \cos \beta L + \left(\frac{w}{\beta^2P} \right) (\cos \beta L - 1) + \left(\frac{wL}{\beta P} \right) \sin \beta L,$$

$$\Rightarrow d = \left(\frac{w}{\beta^2P} \right) (1 - \sec \beta L) + \left(\frac{wL}{\beta P} \right) \tan \beta L - \frac{wL^2}{2P},$$

$$\Rightarrow d = \frac{wL^2}{P} \left(\frac{1 - \sec \beta L}{(\beta L)^2} + \frac{\tan \beta L}{\beta L} - \frac{1}{2} \right).$$

Example 3: For the shown beam-column, derive and solve the differential equation of the deflection curve. (Neglect self weight)

Solution:

$$EI \cdot \frac{d^2 y}{dx^2} = -M_x.$$

But $M_x = \frac{qLx}{6} - Py - \frac{qx^3}{6L},$

$$\therefore EI \cdot \frac{d^2 y}{dx^2} = -\left[\frac{qLx}{6} - Py - \frac{qx^3}{6L}\right],$$

$$\Rightarrow \frac{d^2 y}{dx^2} - \frac{P}{EI} y = \frac{qx^3}{6LEI} - \frac{qLx}{6EI}.$$

Let $\beta^2 = \frac{P}{EI} \Rightarrow \frac{d^2 y}{dx^2} - \beta^2 y = \frac{qx^3}{6LEI} - \frac{qLx}{6EI},$

or $(D^2 - \beta^2)y = \frac{qx^3}{6LEI} - \frac{qLx}{6EI} \Rightarrow m^2 - \beta^2 = 0,$

$$\Rightarrow m^2 = \beta^2 \Rightarrow m_{1,2} = \pm\beta,$$

$$\therefore y_c = C_1 e^{\beta x} + C_2 e^{-\beta x}.$$

Let $y_p = A_0 + A_1 x + A_2 x^2 + A_3 x^3,$

$$\Rightarrow y'_p = A_1 + 2A_2 x + 3A_3 x^2 \Rightarrow y''_p = 2A_2 + 6A_3 x.$$

Substituting,

$$2A_2 + 6A_3 x - \beta^2(A_0 + A_1 x + A_2 x^2 + A_3 x^3) = \frac{qx^3}{6LEI} - \frac{qLx}{6EI},$$

$$\therefore -\beta^2 A_3 = \frac{q}{6LEI} \Rightarrow A_3 = -\frac{q}{6L\beta^2 EI} = -\frac{q}{6LP},$$

$$-\beta^2 A_2 = 0 \Rightarrow A_2 = 0,$$

$$6A_3 - \beta^2 A_1 = -\frac{qL}{6EI} \Rightarrow A_1 = \frac{qL}{6\beta^2 EI} + \frac{6A_3}{\beta^2} = \frac{qL}{6P} - \frac{q}{L\beta^2 P},$$

$$2A_2 - \beta^2 A_0 = 0 \Rightarrow A_0 = \frac{2A_2}{\beta^2} = 0.$$

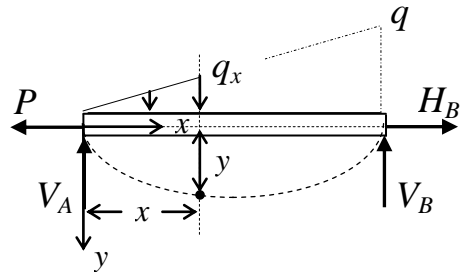
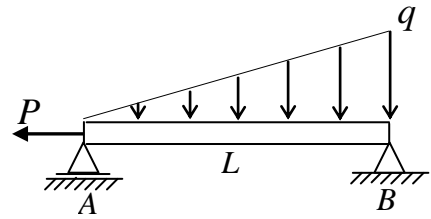

To determine M_x :

From left;

$$M_x = V_A x - Py - \frac{1}{2} q_x \cdot x \cdot \frac{x}{3}.$$

$$\sum (M)_B = 0,$$

$$\frac{1}{2} qL \frac{L}{3} - V_A \cdot L = 0 \Rightarrow V_A = \frac{qL}{6}.$$

$$\frac{q}{L} = \frac{q_x}{x} \Rightarrow q_x = \frac{q \cdot x}{L}.$$

$$\therefore M_x = \frac{qL}{6} \cdot x - Py - \frac{1}{2} \cdot \frac{q \cdot x}{L} \cdot x \cdot \frac{x}{3}$$

$$= \frac{qLx}{6} - Py - \frac{qx^3}{6L}.$$

$$\therefore y_p = \left(\frac{qL}{6P} - \frac{q}{L\beta^2 P} \right) x - \frac{q}{6LP} x^3.$$

$$y = y_c + y_p \Rightarrow y = C_1 e^{\beta x} + C_2 e^{-\beta x} + \left(\frac{qL}{6P} - \frac{q}{L\beta^2 P} \right) x - \frac{q}{6LP} x^3. \quad (\text{G.S})$$

Boundary conditions,

$$1. y(0) = 0 \Rightarrow 0 = C_1 + C_2 + 0 \Rightarrow C_2 = -C_1.$$

$$2. y(L) = 0 \Rightarrow 0 = C_1 e^{\beta L} + C_2 e^{-\beta L} + \frac{qL^2}{6P} - \frac{q}{\beta^2 P} - \frac{qL^2}{6P},$$

$$\Rightarrow C_1 (e^{\beta L} - e^{-\beta L}) = \frac{q}{\beta^2 P} \Rightarrow C_1 = \frac{q}{\beta^2 P (e^{\beta L} - e^{-\beta L})}.$$

$$\begin{aligned} \therefore y &= \frac{q}{\beta^2 P (e^{\beta L} - e^{-\beta L})} e^{\beta x} - \frac{q}{\beta^2 P (e^{\beta L} - e^{-\beta L})} e^{-\beta x} + \left(\frac{qL}{6P} - \frac{q}{L\beta^2 P} \right) x - \frac{q}{6LP} x^3 \\ &= \frac{q(e^{\beta x} - e^{-\beta x})}{\beta^2 P (e^{\beta L} - e^{-\beta L})} + \left(\frac{qL}{6P} - \frac{q}{L\beta^2 P} \right) x - \frac{q}{6LP} x^3 \quad \left(\sinh \alpha = \frac{e^\alpha - e^{-\alpha}}{2} \right) \\ &= \frac{q}{\beta^2 P} \left(\frac{\sinh \beta x}{\sinh \beta L} + \frac{\beta^2 L x}{6} - \frac{x}{L} - \frac{\beta^2 x^3}{6L} \right). \quad (\text{P.S}) \end{aligned}$$

4. Simple Vibration

Any system having mass and elasticity can vibrate when it is subjected to an exciting force. The study of a vibrated system requires determination of displacement of each point in that system. In continuous bodies, there is an infinite number of these points, thus the analysis is very complicated. So that, simplifications are used by considering only a limited number of these points, each point may have motion in one, two, or three directions and rotation about one, two, or three axes. Each component of these motions is known as the degree of freedom 'DOF'. So that, each point may have one to six DOF. The DOF of the whole system is the sum of the degrees of freedom for all considered points.

- * Free vibration: is the vibration that occurs in the absence of exciting forces. This vibration is usually caused by an initial displacement and/or initial velocity.
- * Forced vibration: is the vibration that occurs due to the effect of an exciting force.
- * Undamped vibration: When the motion is not subjected to a counter effect, such as friction or air resistance. In this case, the kinetic energy is constant and the amplitude of motion remains unchanged.
- * Damped vibration: When the motion is subjected to a counter effect. In this case, the kinetic energy is dissipated during motion and the amplitude is reduced with time. Actually, all systems must have some damping.

Free vibration

Undamped free vibration

Systems having single DOF can be represented by a spring-mass system as shown in the figure below.

Case I: Static;

A mass m is attached to a spring of stiffness k . At equilibrium:

$$\sum F_y = 0 \quad \Rightarrow \quad W - P = 0 \quad \Rightarrow \quad W = P \quad \Rightarrow \quad W = k \cdot \Delta .$$

$$\therefore k = \frac{W}{\Delta} \quad \Rightarrow \quad k = \frac{mg}{\Delta} .$$

Case II: Dynamic;

If the mass oscillates due to an initial displacement or velocity, then at any time t :

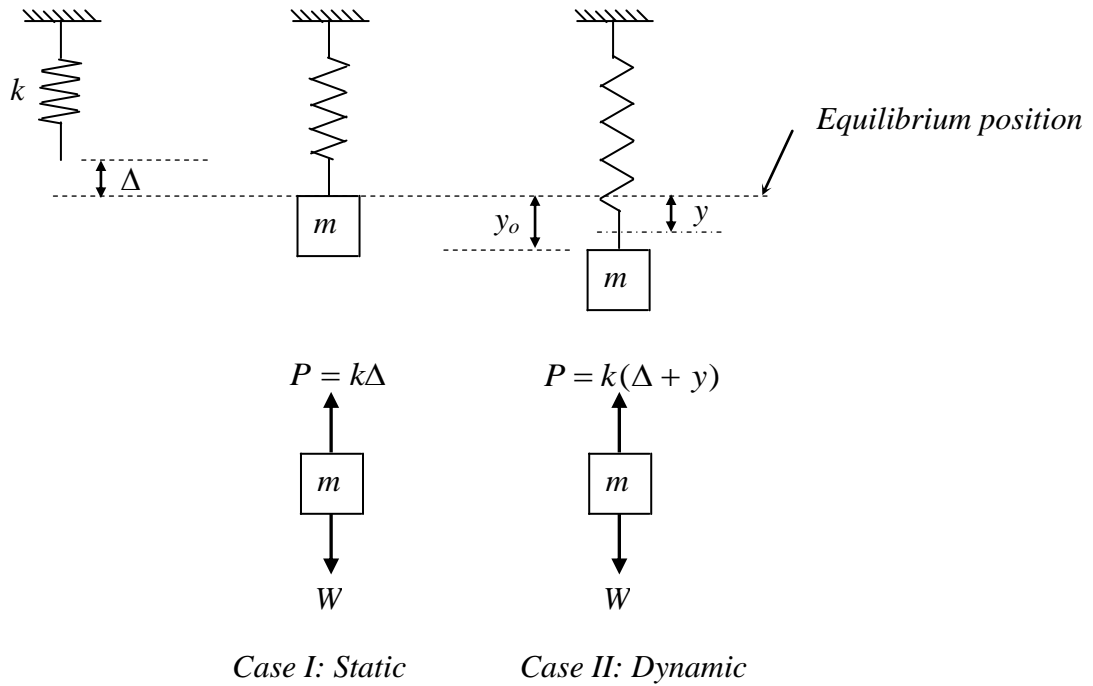

$$\begin{aligned}
 \sum F_y = m.a &\Rightarrow W - P = m.a &\Rightarrow W - k(\Delta + y) = m.\ddot{y}, \\
 \Rightarrow W - k\Delta - ky &= m.\ddot{y} &\Rightarrow m.\ddot{y} + ky = 0, \\
 \Rightarrow \ddot{y} + \frac{k}{m}y &= 0.
 \end{aligned}$$

$$\begin{aligned}
 \text{Let } \omega^2 = \frac{k}{m} &\Rightarrow \ddot{y} + \omega^2 y = 0 \quad \text{or} \quad (D^2 + \omega^2)y = 0, \\
 \Rightarrow r^2 + \omega^2 = 0 &\Rightarrow r^2 = -\omega^2 \Rightarrow r_{1,2} = \pm \omega i,
 \end{aligned}$$

$$\therefore y = A \cos \omega t + B \sin \omega t. \quad (\text{Simple harmonic motion})$$

Initial conditions,

$$\text{At } t = 0, \quad y = y_o \quad \text{and} \quad v = \dot{y} = v_o.$$

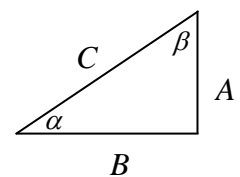

To find the amplitude of motion,

$$\text{Let } A^2 + B^2 = C^2.$$

$$y = C \left(\frac{A}{C} \cos \omega t + \frac{B}{C} \sin \omega t \right),$$

$$\Rightarrow y = C(\sin \alpha \cos \omega t + \cos \alpha \sin \omega t) \Rightarrow y = C \sin(\omega t + \alpha),$$

$$\text{or } y = C \left(\frac{A}{C} \cos \omega t + \frac{B}{C} \sin \omega t \right),$$

$$\Rightarrow y = C(\cos \beta \cos \omega t + \sin \beta \sin \omega t) \Rightarrow y = C \cos(\omega t - \beta),$$

$$\begin{aligned}
 \cos \alpha &= B/C, \\
 \sin \alpha &= A/C, \\
 \alpha &= \tan^{-1}(A/B), \\
 \beta &= \tan^{-1}(B/A).
 \end{aligned}$$

where,

C is the amplitude of motion. (m)

α and β are the phase angles (shifting angles) ($\alpha + \beta = \pi/2$). (rad)

ω is the circular or angular frequency $\Rightarrow \omega = \sqrt{\frac{k}{m}}$. (rad/s)

f is the natural frequency $\Rightarrow f = \frac{\omega}{2\pi}$. ($cycle/s=hertz$)

T is the period of motion (i.e. the time required to complete one circle of motion)

$$\Rightarrow T = \frac{2\pi}{\omega} = \frac{1}{f}. \quad (s)$$

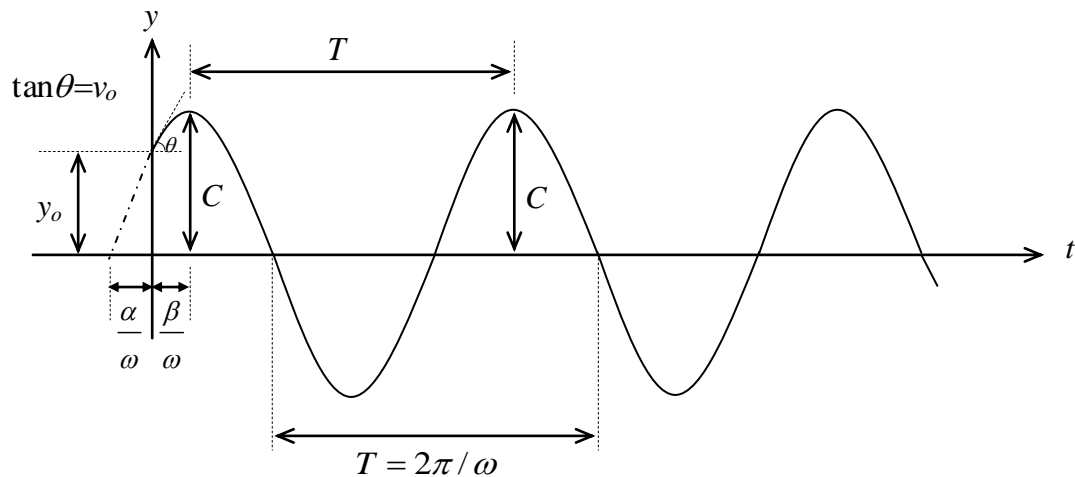

Example: A mass of 4 kg is attached to a spring of 1.6 kN/m stiffness. The mass is pulled down with a velocity of 0.6 m/s and released at 4 cm below the equilibrium position. Find the equation of motion, angular frequency, natural frequency, period of motion, and amplitude of motion (maximum displacement). Then, find the minimum time at which the mass passes through the equilibrium position.

Solution:

The case is undamped free vibration,

$$\therefore m\ddot{y} + ky = 0 \quad \Rightarrow \quad \ddot{y} + \frac{k}{m}y = 0.$$

$$\text{Let } \omega^2 = \frac{k}{m} \Rightarrow \omega^2 = \frac{1.6 \times 10^3}{4} = 400 \Rightarrow \omega = 20 \text{ rad/s. (Angular frequency)}$$

$$\therefore \ddot{y} + 400y = 0 \quad \text{or} \quad (D^2 + 400)y = 0,$$

$$\Rightarrow r^2 + 400 = 0 \Rightarrow r^2 = -400 \Rightarrow r_{1,2} = \pm 20i,$$

$$\therefore y = A \cos 20t + B \sin 20t. \quad (\text{G.S})$$

Initial conditions,

$$1. y(0) = +0.04m \Rightarrow 0.04 = A + 0 \Rightarrow A = 0.04.$$

$$2. v(0) = \dot{y}(0) = +0.6m/s, \quad \dot{y} = -20A \sin 20t + 20B \cos 20t,$$

$$\Rightarrow 0.6 = 0 + 20B \Rightarrow B = 0.03.$$

$$\therefore y = 0.04 \cos 20t + 0.03 \sin 20t. \quad (\text{P.S})$$

$$f = \frac{\omega}{2\pi} = \frac{20}{2\pi} = 3.183 \text{ Hz}. \quad (\text{Natural frequency})$$

$$T = \frac{2\pi}{\omega} = \frac{1}{f} = 0.314 \text{ s}. \quad (\text{Period of motion})$$

$$C = \sqrt{A^2 + B^2} = \sqrt{0.04^2 + 0.03^2} = 0.05 \text{ m}. \quad (\text{Amplitude of motion})$$

The mass passes through the equilibrium position when $y = 0$,

$$\alpha = \tan^{-1}(A/B) = \tan^{-1}(0.04/0.03) = 0.9273 \text{ rad},$$

$$\therefore y = C \sin(\omega t + \alpha) = 0.05 \sin(20t + 0.9273).$$

$$\text{At } y = 0 \Rightarrow 0 = 0.05 \sin(20t + 0.9273) \Rightarrow \sin(20t + 0.9273) = 0,$$

$$\text{either } 20t + 0.9273 = 0 \Rightarrow t = -0.046, \text{ (neglected)}$$

$$\text{or } 20t + 0.9273 = \pi \Rightarrow t = 0.1107 \text{ s}.$$

Damped free vibration

In all vibrating system there is some energy dissipation (damping). So that, the amplitude of motion decreases with time until vanishes. Viscous damping is assumed to be proportional with velocity,

$$\therefore \text{Viscous damping } D \propto v \Rightarrow D = cv \Rightarrow D = c\dot{y},$$

where c is the damping constant or the damping coefficient ($N.s/m$).

In the dynamic case;

$$\sum F_y = m.a \Rightarrow W - P - D = m.a \Rightarrow W - k(\Delta + y) - c\dot{y} = m.\ddot{y},$$

$$\Rightarrow W - k\Delta - ky - c\dot{y} = m.\ddot{y}.$$

$$\text{But, from static case } W = k\Delta \Rightarrow -ky - c\dot{y} = m.\ddot{y},$$

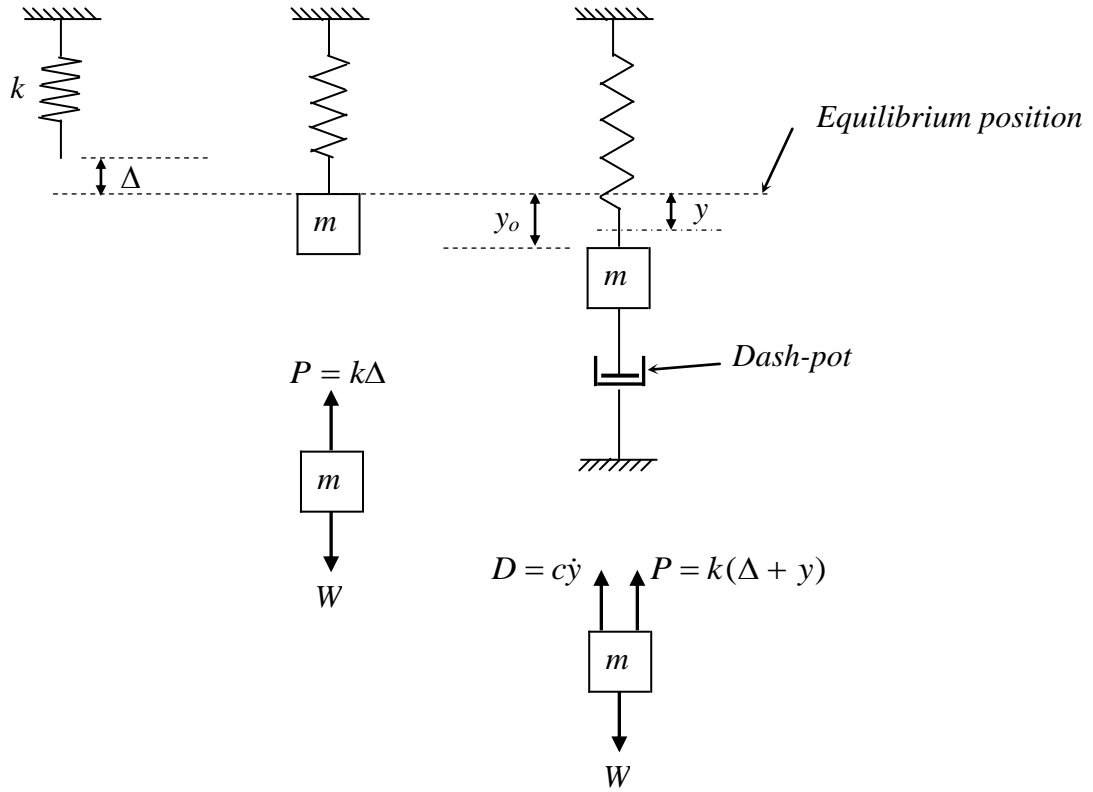

$$\therefore m\ddot{y} + c\dot{y} + ky = 0 \quad \text{or} \quad (mD^2 + cD + k)y = 0,$$

$$\therefore mr^2 + cr + k = 0 \quad \Rightarrow \quad r_{1,2} = \frac{-c \pm \sqrt{c^2 - 4km}}{2m}.$$

Case 1; When $c^2 - 4km = 0 \Rightarrow c = 2\sqrt{km} = c_{cr}$, (Critical damping)

$$r_1 = r_2 = \frac{-c}{2m} \Rightarrow y = Ae^{-ct/2m} + Bte^{-ct/2m}. \quad (\text{No oscillations})$$

Case 2; When $c^2 - 4km > 0 \Rightarrow c > 2\sqrt{km}$ (i.e. $c > c_{cr}$), (Over damping)

$$r_1 \neq r_2 \Rightarrow y = Ae^{r_1 t} + Be^{r_2 t}. \quad (\text{No oscillations})$$

Case 3; When $c^2 - 4km < 0 \Rightarrow c < 2\sqrt{km}$ (i.e. $c < c_{cr}$), (Under damping)

$$r_{1,2} = \frac{-c \pm \sqrt{4km - c^2}i}{2m} = -\frac{c}{2m} \pm \sqrt{\frac{4km - c^2}{4m^2}}i,$$

$$\therefore y = e^{-ct/2m} (A \cos \omega_D t + B \sin \omega_D t), \quad (\text{Oscillations occur})$$

$$\text{or } y = Ce^{-ct/2m} \sin(\omega_D t + \alpha),$$

$$\text{or } y = Ce^{-ct/2m} \cos(\omega_D t - \beta),$$

$$\text{where, } \omega_D = \sqrt{\frac{4km - c^2}{4m^2}} = \sqrt{\frac{k}{m} - \frac{c^2}{4m^2}} = \sqrt{\frac{k}{m}} \sqrt{1 - \frac{c^2}{4km}} = \omega \sqrt{1 - \frac{c^2}{(2\sqrt{km})^2}}$$

$$= \omega \sqrt{1 - \frac{c^2}{(c_{cr})^2}} = \omega \sqrt{1 - \lambda^2},$$

where, $\lambda = \frac{c}{c_{cr}}$ is the damping ratio.

* In almost all cases, the state is under damping.

* For structures, $c = (0.02 - 0.2)c_{cr}$.

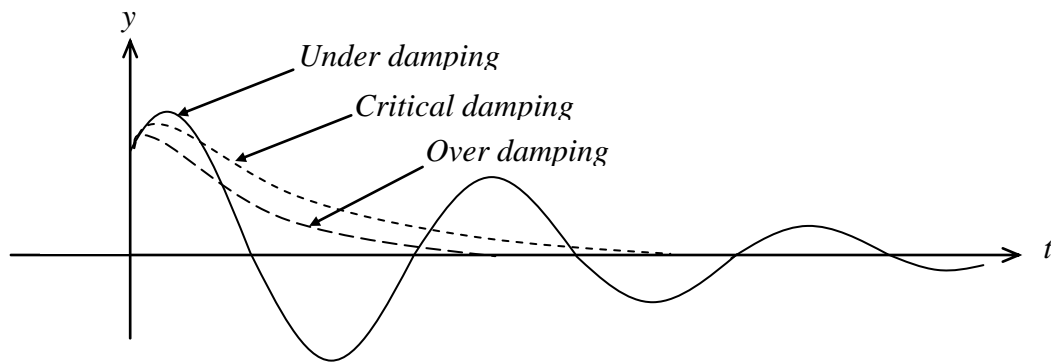

Example: A 10 kg mass is attached to a 1.5 m long spring. At equilibrium, the spring measures 2.481 m. If the mass is pushed up and released from rest at 0.2 m above the equilibrium position, find the displacement as a function of time, critical damping constant, natural frequency, and period of motion. (Assume the damping coefficient $c = 20 \text{ N.s/m}$).

Solution:

The case is damped free vibration,

$$\therefore m\ddot{y} + c\dot{y} + ky = 0,$$

$$k = \frac{W}{\Delta} = \frac{mg}{\Delta} = \frac{10 \times 9.81}{(2.481 - 1.5)} = 100 \text{ N/m},$$

$$\therefore 10\ddot{y} + 20\dot{y} + 100y = 0 \quad \text{or} \quad (10D^2 + 20D + 100)y = 0,$$

$$\therefore 10r^2 + 20r + 100 = 0 \quad \Rightarrow \quad r_{1,2} = \frac{-20 \pm \sqrt{20^2 - 4(10)(100)}}{2(10)} = -1 \pm 3i,$$

$$\therefore y = e^{-t}(A \cos 3t + B \sin 3t). \quad (\text{Under damping}) \quad (\text{G.S})$$

Initial conditions,

$$1. y(0) = -0.2m \quad \Rightarrow \quad -0.2 = A + 0 \quad \Rightarrow \quad A = -0.2.$$

$$2. v(0) = \dot{y}(0) = 0, \quad \dot{y} = e^{-t}(-3A \sin 3t + 3B \cos 3t) - e^{-t}(A \cos 3t + B \sin 3t),$$

$$\Rightarrow 0 = 0 + 3B - (A + 0) \quad \Rightarrow \quad B = A/3 = -0.2/3.$$

$$\therefore y = e^{-t}(-0.2 \cos 3t - \frac{0.2}{3} \sin 3t) \quad \text{or} \quad y = -\frac{1}{15} e^{-t}(3 \cos 3t + \sin 3t). \quad (\text{P.S})$$

$$c_{cr} = 2\sqrt{km} = 2\sqrt{100 \times 10} = 63.25 \text{ N.s/m}. \quad (\text{Critical damping})$$

$$f = \frac{\omega_D}{2\pi} = \frac{3}{2\pi} = 0.477 \text{ Hz}. \quad (\text{Natural frequency})$$

$$T = \frac{2\pi}{\omega_D} = \frac{1}{f} = 2.09 \text{ s}. \quad (\text{Period of motion})$$

Forced vibration

Undamped forced vibration

In the dynamic case;

$$\sum F_y = m.a \quad \Rightarrow \quad F + W - P = m.a \quad \Rightarrow \quad F + W - k(\Delta + y) = m.\ddot{y},$$

$$\Rightarrow \quad F + W - k\Delta - ky = m.\ddot{y}.$$

But, from static case $W = k\Delta \Rightarrow F - ky = m.\ddot{y} \Rightarrow m.\ddot{y} + ky = F.$

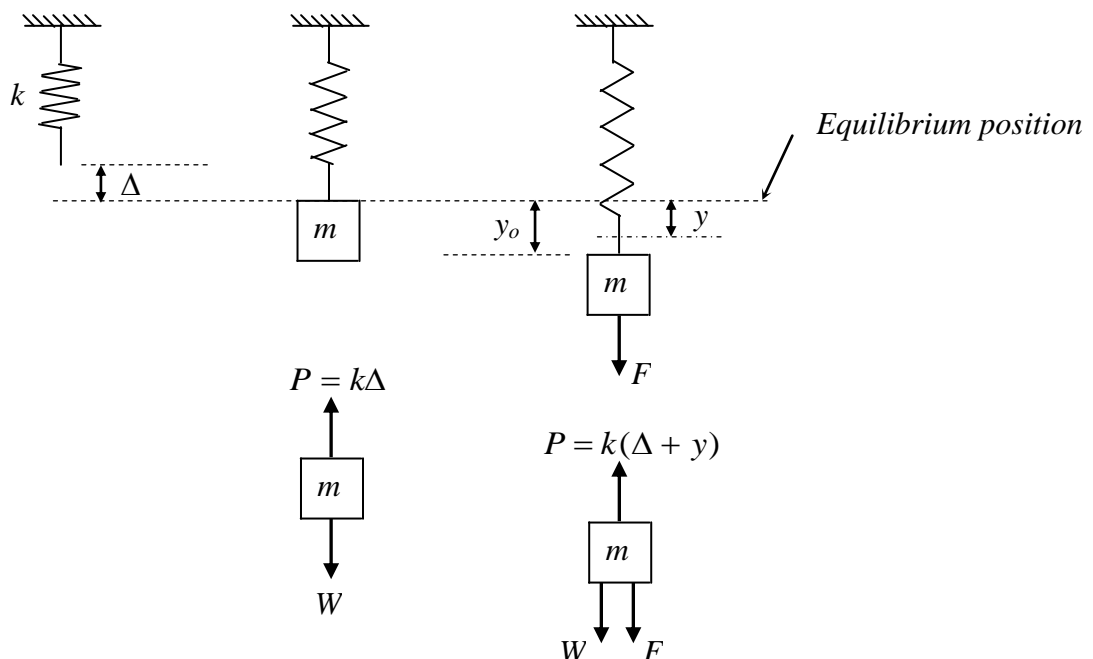

Damped forced vibration

In the dynamic case;

$$\sum F_y = m.a \Rightarrow F + W - P - D = m.a \Rightarrow F + W - k(\Delta + y) - c\dot{y} = m.\ddot{y},$$

$$\Rightarrow F + W - k\Delta - ky - c\dot{y} = m.\ddot{y}.$$

But, from static case $W = k\Delta \Rightarrow F - ky - c\dot{y} = m.\ddot{y} \Rightarrow m.\ddot{y} + c\dot{y} + ky = F.$

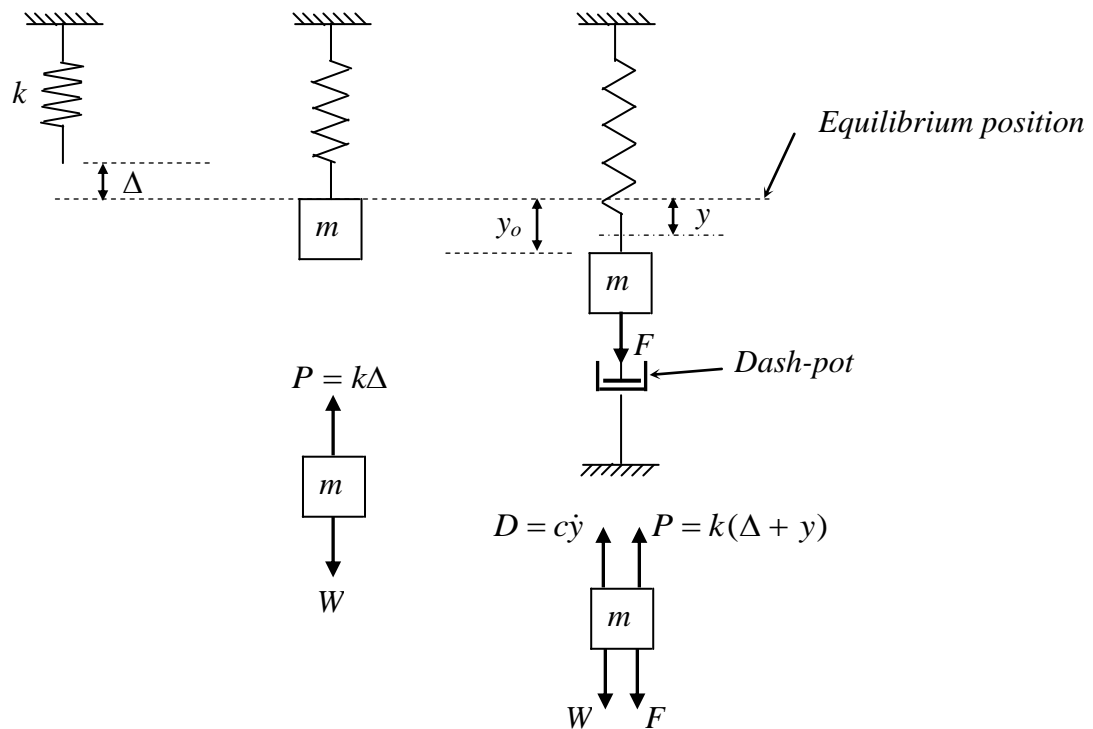

Example 1: A 5 kg mass is connected to a spring of 8.5 kN/m stiffness and subjected to an exciting dynamic force of $50\cos 30t$ kN. Assuming the viscous damping coefficient is 24% of the critical damping, determine the equation of motion of the mass. (Initial displacement and velocity are zero)

Solution:

The case is damped forced vibration,

$$\therefore m.\ddot{y} + c\dot{y} + ky = F,$$

$$c_{cr} = 2\sqrt{km} = 2\sqrt{8.5 \times 1000 \times 5} = 412.3 \text{ N.s/m},$$

$$c = 0.24c_{cr} = 0.24 \times 412.3 \approx 100 \text{ N.s/m},$$

$$\therefore 5\ddot{y} + 100\dot{y} + 8500y = 50000\cos 30t \quad \text{or} \quad (5D^2 + 100D + 8500)y = 50000\cos 30t,$$

$$\therefore 5r^2 + 100r + 8500 = 0 \Rightarrow r_{1,2} = \frac{-100 \pm \sqrt{100^2 - 4(5)(8500)}}{2(5)} = -10 \pm 40i,$$

$$\therefore y_c = e^{-10t} (A\cos 40t + B\sin 40t).$$

Let $y_p = C_1 \cos 30t + C_2 \sin 30t$,

$$\Rightarrow \dot{y}_p = -30C_1 \sin 30t + 30C_2 \cos 30t \Rightarrow \ddot{y}_p = -900C_1 \cos 30t - 900C_2 \sin 30t.$$

Substituting,

$$5(-900C_1 \cos 30t - 900C_2 \sin 30t) + 100(-30C_1 \sin 30t + 30C_2 \cos 30t) + 8500(C_1 \cos 30t + C_2 \sin 30t) = 50000 \cos 30t,$$

$$(4000C_1 + 3000C_2) \cos 30t + (-3000C_1 + 4000C_2) \sin 30t = 50000 \cos 30t,$$

$$\therefore 4000C_1 + 3000C_2 = 50000 \quad \dots\dots\dots (1)$$

$$-3000C_1 + 4000C_2 = 0 \quad \dots\dots\dots (2)$$

Solving Eqs. (1) & (2) simultaneously yields, $C_1 = 8$ and $C_2 = 6$.

$$\therefore y_p = 8 \cos 30t + 6 \sin 30t.$$

$$y = y_c + y_p \Rightarrow y = e^{-10t} (A \cos 40t + B \sin 40t) + 8 \cos 30t + 6 \sin 30t. \quad (\text{G.S})$$

Initial conditions,

$$1. y(0) = 0 \Rightarrow 0 = A + 0 + 8 + 0 \Rightarrow A = -8.$$

$$2. v(0) = \dot{y}(0) = 0,$$

$$\dot{y} = e^{-10t} (-40A \sin 40t + 40B \cos 40t) - 10e^{-10t} (A \cos 40t + B \sin 40t) - 30(8) \sin 30t + 30(6) \cos 30t,$$

$$\Rightarrow 0 = 0 + 40B - 10(A + 0) - 0 + 180 \Rightarrow B = -6.5.$$

$$\therefore y = e^{-10t} (-8 \cos 40t - 6.5 \sin 40t) + 8 \cos 30t + 6 \sin 30t,$$

$$\text{or } y = -e^{-10t} (8 \cos 40t + 6.5 \sin 40t) + 8 \cos 30t + 6 \sin 30t. \quad (\text{P.S})$$

Example 2: Find the equation of motion for a system subjected to the external force $F \sin \omega_f t$. (Neglect damping)

Solution:

The case is undamped forced vibration,

$$\therefore m \ddot{y} + ky = F \sin \omega_f t \Rightarrow \ddot{y} + \frac{k}{m} y = \frac{F}{m} \sin \omega_f t.$$

$$\text{Let } \omega^2 = \frac{k}{m} \Rightarrow \ddot{y} + \omega^2 y = \frac{F}{m} \sin \omega_f t,$$

$$(D^2 + \omega^2)y = 0 \Rightarrow r^2 + \omega^2 = 0 \Rightarrow r^2 = -\omega^2 \Rightarrow r_{1,2} = \pm \omega i,$$

$$\therefore y_c = A \cos \omega t + B \sin \omega t.$$

Let $y_p = C_1 \cos \omega_f t + C_2 \sin \omega_f t$,

$$\Rightarrow \dot{y}_p = -\omega_f C_1 \sin \omega_f t + \omega_f C_2 \cos \omega_f t \Rightarrow \ddot{y}_p = -\omega_f^2 C_1 \cos \omega_f t - \omega_f^2 C_2 \sin \omega_f t.$$

Substituting,

$$-\omega_f^2 C_1 \cos \omega_f t - \omega_f^2 C_2 \sin \omega_f t + \omega^2 (C_1 \cos \omega_f t + C_2 \sin \omega_f t) = \frac{F}{m} \sin \omega_f t,$$

$$(-\omega_f^2 C_1 + \omega^2 C_1) \cos \omega_f t + (-\omega_f^2 C_2 + \omega^2 C_2) \sin \omega_f t = \frac{F}{m} \sin \omega_f t,$$

$$\therefore -\omega_f^2 C_1 + \omega^2 C_1 = 0 \Rightarrow (-\omega_f^2 + \omega^2) C_1 = 0 \Rightarrow C_1 = 0,$$

$$-\omega_f^2 C_2 + \omega^2 C_2 = \frac{F}{m} \Rightarrow (-\omega_f^2 + \omega^2) C_2 = \frac{F}{m} \Rightarrow C_2 = \frac{F}{m(\omega^2 - \omega_f^2)},$$

$$\therefore y_p = \frac{F}{m(\omega^2 - \omega_f^2)} \sin \omega_f t.$$

$$y = y_c + y_p \Rightarrow y = A \cos \omega t + B \sin \omega t + \frac{F}{m(\omega^2 - \omega_f^2)} \sin \omega_f t. \quad (\text{G.S})$$

Notes,

* If $\omega_f \rightarrow \omega$, then $y \rightarrow \infty$. (Resonance)

* If $\omega_f = \omega$, then $y = A \cos \omega t + B \sin \omega t - \frac{F}{2m\omega} t \cos \omega t$.

(i.e. solution increases in amplitude as t increases)

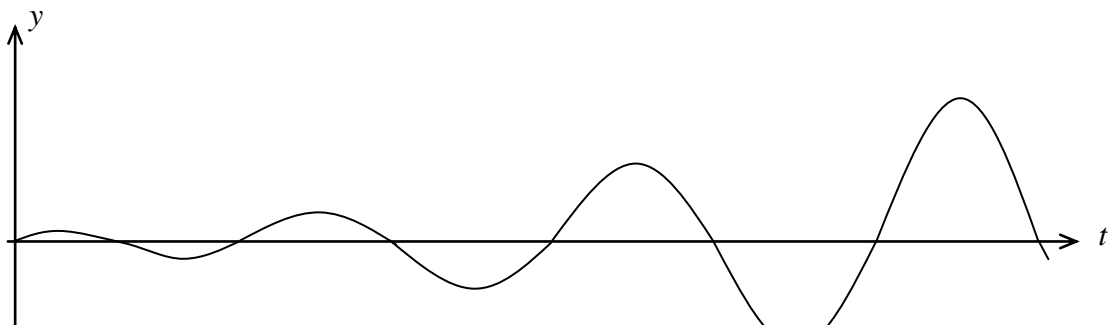

Vibration of structures

Example 1: A mass m is put on the end of a cantilever beam, of negligible mass, as shown below. Determine the natural frequency of this system.

Solution :

Let the deflection at the free end is Δ .

The deflection at the free end due to a tip concentrated load P is,

$$\Delta = \frac{PL^3}{3EI}.$$

The stiffness for a single DOF system,

$$k = \frac{P}{\Delta} \Rightarrow k = \frac{P}{PL^3/3EI} \Rightarrow \therefore k = \frac{3EI}{L^3}.$$

$$\omega = \sqrt{\frac{k}{m}} \Rightarrow \omega = \sqrt{\frac{3EI}{mL^3}},$$

$$f = \frac{\omega}{2\pi} \Rightarrow f = \frac{1}{2\pi} \sqrt{\frac{3EI}{mL^3}}.$$

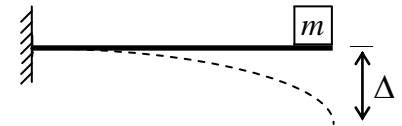
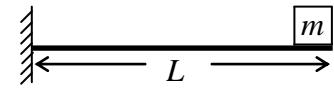

Notes,

* The values of k for various cases are as shown below.

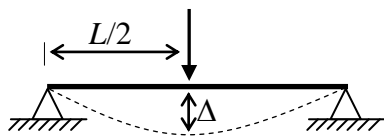

$$k = 48EI / L^3$$

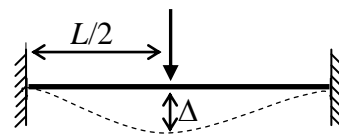

$$k = 192EI / L^3$$

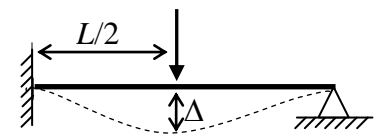

$$k = 107.33EI / L^3$$

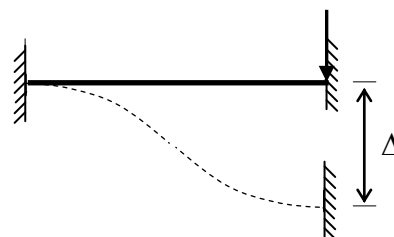

$$k = 12EI / L^3$$

* The equivalent stiffness for “in series” connection is,

$$\Delta = \Delta_1 + \Delta_2$$

$$\frac{P}{k_{eq}} = \frac{P}{k_1} + \frac{P}{k_2}$$

$$\therefore \frac{1}{k_{eq}} = \frac{1}{k_1} + \frac{1}{k_2}.$$

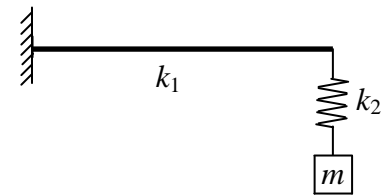

* The equivalent stiffness for “in parallel” connection is,

$$P = P_1 + P_2$$

$$k_{eq}\Delta = k_1\Delta + k_2\Delta$$

$$\therefore k_{eq} = k_1 + k_2.$$

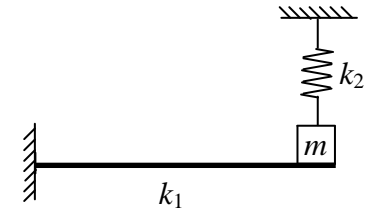

Example 2: Determine the natural frequency of the system shown in the figure. The

beam is of negligible mass. Given $m = 25 \text{ kg}$, $E = 200 \text{ GPa}$, $I = 5 \times 10^{-7} \text{ m}^4$, and $k_{spring} = 5 \text{ kN/m}$.

Solution:

The stiffness for a cantilever beam subjected to a tip concentrated load is,

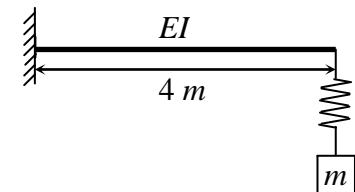

$$k_{beam} = \frac{3EI}{L^3} \quad \Rightarrow \quad k_{beam} = \frac{3(200 \times 10^9)(5 \times 10^{-7})}{4^3} = 4687.5 \text{ N/m}.$$

$$\frac{1}{k_{eq}} = \frac{1}{k_{beam}} + \frac{1}{k_{spring}} \quad \Rightarrow \quad \frac{1}{k_{eq}} = \frac{1}{4687.5} + \frac{1}{5000} \quad \Rightarrow \quad k_{eq} = 2419.4 \text{ N/m}.$$

$$\omega = \sqrt{\frac{k}{m}} \quad \Rightarrow \quad \omega = \sqrt{\frac{2419.4}{25}} = 9.837 \text{ rad/s}.$$

$$f = \frac{\omega}{2\pi} \quad \Rightarrow \quad f = \frac{9.837}{2\pi} = 1.566 \text{ Hz}.$$

Example 3: Assuming the damping ratio is equal to 0.1 and neglecting self weights of all members, find the equation of motion of the frame, shown in the figure, under the action of the exciting dynamic force. The initial displacement and velocity are zero. For columns, take $EI = 60 \text{ kN/m}^2$ and $k = 3EI/L^3$.

Solution:

The case is damped forced vibration,

$$\therefore m \cdot \ddot{y} + c\dot{y} + ky = F .$$

$$m = 10 \times 4 = 40 \text{ kg} .$$

$$k_{eq} = k_{column1} + k_{column2}$$

$$= \left(\frac{3EI}{L^3} \right)_{column1} + \left(\frac{3EI}{L^3} \right)_{column2}$$

$$= \frac{3(60 \times 10^3)}{4^3} + \frac{3(60 \times 10^3)}{2^3} = 25312.5 \text{ N/m} .$$

$$c_{cr} = 2\sqrt{km} = 2\sqrt{25312.5 \times 40} = 2012.46 \text{ N.s/m} .$$

But, $\lambda = \frac{c}{c_{cr}} = 0.1 \Rightarrow c = 0.1c_{cr} = 0.1 \times 2012.46 = 201.246 \text{ N.s/m} .$

$$\therefore 40\ddot{y} + 201.246\dot{y} + 25312.5y = 10 \times 10^3 \cos 3t ,$$

or $\ddot{y} + 5.03\dot{y} + 632.813y = 250\cos 3t \Rightarrow (D^2 + 5.03D + 632.813)y = 250\cos 3t .$

$$\therefore r^2 + 5.03r + 632.813 = 0 \Rightarrow r_{1,2} = \frac{-5.03 \pm \sqrt{5.03^2 - 4(632.813)}}{2} = -2.515 \pm 25.03i ,$$

$$\therefore y_c = e^{-2.515t} (A\cos 25.03t + B\sin 25.03t) .$$

Let $y_p = C_1 \cos 3t + C_2 \sin 3t ,$

$$\Rightarrow \dot{y}_p = -3C_1 \sin 3t + 3C_2 \cos 3t \Rightarrow \ddot{y}_p = -9C_1 \cos 3t - 9C_2 \sin 3t .$$

Substituting,

$$-9C_1 \cos 3t - 9C_2 \sin 3t + 5.03(-3C_1 \sin 3t + 3C_2 \cos 3t) + 632.813(C_1 \cos 3t + C_2 \sin 3t) = 250\cos 3t ,$$

$$(623.813C_1 + 15.09C_2)\cos 3t + (-15.09C_1 + 623.813C_2)\sin 3t = 250\cos 3t ,$$

$$\therefore 623.813C_1 + 15.09C_2 = 250 \quad \dots\dots\dots (1)$$

$$-15.09C_1 + 623.813C_2 = 0 \quad \dots\dots\dots (2)$$

Solving Eqs. (1) & (2) simultaneously yields, $C_1 \approx 0.4$ and $C_2 \approx 0.01$.

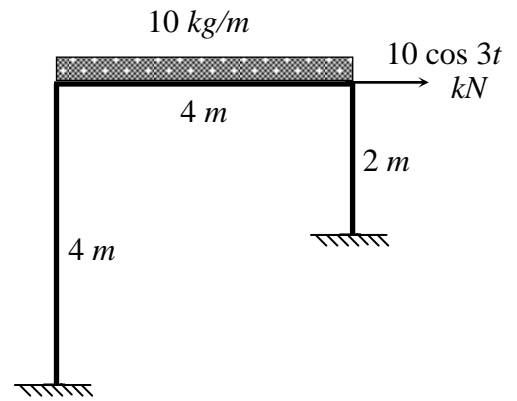

$$\therefore y_p = 0.4\cos 3t + 0.01\sin 3t.$$

$$y = y_c + y_p \Rightarrow y = e^{-2.515t}(A\cos 25.03t + B\sin 25.03t) + 0.4\cos 3t + 0.01\sin 3t. \quad (\text{G.S})$$

Initial conditions,

$$1. y(0) = 0 \quad \Rightarrow \quad 0 = A + 0 + 0.4 + 0 \quad \Rightarrow \quad A = -0.4.$$

$$2. v(0) = \dot{y}(0) = 0,$$

$$\dot{y} = e^{-2.515t}(-25.03A\sin 25.03t + 25.03B\cos 25.03t) - 2.515e^{-2.515t}(A\cos 25.03t + B\sin 25.03t) - 3(0.4)\sin 3t + 3(0.01)\cos 3t,$$

$$\Rightarrow 0 = 0 + 25.03B - 2.515(A + 0) - 0 + 3(0.01) \quad \Rightarrow \quad B = -0.0414.$$

$$\therefore y = e^{-2.515t}(-0.4\cos 25.03t - 0.0414\sin 25.03t) + 0.4\cos 3t + 0.01\sin 3t. \quad (\text{P.S})$$

6- Simultaneous Linear Ordinary Differential Equations

Example 1: Solve the following differential equations

$$\frac{dy}{dt} + \frac{dx}{dt} - 3t = 0,$$

$$2\frac{dx}{dt} + y = 0.$$

Solution :

Using D-operator gives,

$$Dy + Dx = 3t, \quad \dots\dots\dots (1)$$

$$y + 2Dx = 0. \quad \dots\dots\dots (2)$$

In matrix form:

$$\begin{bmatrix} D & D \\ 1 & 2D \end{bmatrix} \begin{Bmatrix} y \\ x \end{Bmatrix} = \begin{bmatrix} 3t \\ 0 \end{bmatrix}.$$

Using Cramer's rule to solve the above matrix, gives

$$y = \frac{\begin{vmatrix} 3t & D \\ 0 & 2D \end{vmatrix}}{\begin{vmatrix} D & D \\ 1 & 2D \end{vmatrix}} = \frac{2D(3t) - D(0)}{2D(D) - 1(D)} = \frac{6}{2D^2 - D},$$

or $(2D^2 - D)y = 6$. (Non-homogeneous linear ODE with constant coefficients)

$$2m^2 - m = 0 \quad \Rightarrow \quad m(2m - 1) = 0 \quad \Rightarrow \quad m_1 = 0 \quad \text{and} \quad m_2 = 1/2.$$

$$\therefore y_c = C_1 + C_2 e^{t/2}.$$

Let $y_p = A_o t \quad \Rightarrow \quad y'_p = A_o \quad \Rightarrow \quad y''_p = 0.$

Substituting,

$$2(0) - A_o = 6 \quad \Rightarrow \quad A_o = -6 \quad \Rightarrow \quad y_p = -6t.$$

$$y = y_c + y_p \quad \Rightarrow \quad y = C_1 + C_2 e^{t/2} - 6t.$$

Similarly,

$$x = \frac{\begin{vmatrix} D & 3t \\ 1 & 0 \end{vmatrix}}{\begin{vmatrix} D & D \\ 1 & 2D \end{vmatrix}} = \frac{D(0) - 3t(1)}{2D(D) - 1(D)} = \frac{-3t}{2D^2 - D},$$

or $(2D^2 - D)x = -3t$. (Non-homogeneous linear ODE with constant coefficients)

$$2m^2 - m = 0 \quad \Rightarrow \quad m(2m - 1) = 0 \quad \Rightarrow \quad m_1 = 0 \quad \text{and} \quad m_2 = 1/2.$$

$$\therefore x_c = C_3 + C_4 e^{t/2}.$$

$$\text{Let } x_p = (B_o + B_1 t)t = B_o t + B_1 t^2 \quad \Rightarrow \quad x'_p = B_o + 2B_1 t \quad \Rightarrow \quad x''_p = 2B_1.$$

Substituting,

$$2(2B_1) - (B_o + 2B_1 t) = -3t.$$

$$\therefore -2B_1 = -3 \quad \Rightarrow \quad B_1 = 3/2,$$

$$4B_1 - B_o = 0 \quad \Rightarrow \quad B_o = 4B_1 = 4(3/2) = 6.$$

$$\therefore x_p = 6t + \frac{3}{2}t^2.$$

$$x = x_c + x_p \quad \Rightarrow \quad x = C_3 + C_4 e^{t/2} + 6t + \frac{3}{2}t^2.$$

Substituting x and y in Eq. (2) gives,

$$C_1 + C_2 e^{t/2} - 6t + 2\left(\frac{1}{2}C_4 e^{t/2} + 6 + 3t\right) = 0,$$

$$C_1 + 12 + (C_2 + C_4)e^{t/2} = 0,$$

$$\therefore C_1 + 12 = 0 \quad \Rightarrow \quad C_1 = -12,$$

$$C_2 + C_4 = 0 \quad \Rightarrow \quad C_2 = -C_4.$$

$$\therefore y = -12 - C_4 e^{t/2} - 6t \quad \text{and} \quad x = C_3 + C_4 e^{t/2} + 6t + \frac{3}{2}t^2,$$

$$\text{or } y = -12 - Ae^{t/2} - 6t \quad \text{and} \quad x = B + Ae^{t/2} + 6t + \frac{3}{2}t^2. \quad (\text{G.S})$$

Example 2: Solve

$$\frac{dy}{dt} + \frac{dx}{dt} + 3y + 5x - e^{-t} = 0,$$

$$2\frac{dx}{dt} + \frac{dy}{dt} + x + y - 3 = 0.$$

Solution :

Using D-operator gives,

$$Dx + 5x + Dy + 3y = e^{-t} \Rightarrow (D + 5)x + (D + 3)y = e^{-t}, \quad \dots\dots\dots (1)$$

$$2Dx + x + Dy + y = 3 \Rightarrow (2D + 1)x + (D + 1)y = 3, \quad \dots\dots\dots (2)$$

In matrix form:

$$\begin{bmatrix} D + 5 & D + 3 \\ 2D + 1 & D + 1 \end{bmatrix} \begin{Bmatrix} x \\ y \end{Bmatrix} = \begin{bmatrix} e^{-t} \\ 3 \end{bmatrix}.$$

Using Cramer's rule to solve the above matrix, gives

$$x = \frac{\begin{vmatrix} e^{-t} & D + 3 \\ 3 & D + 1 \end{vmatrix}}{\begin{vmatrix} D + 5 & D + 3 \\ 2D + 1 & D + 1 \end{vmatrix}} = \frac{(D + 1)e^{-t} - (D + 3)(3)}{(D + 5)(D + 1) - (2D + 1)(D + 3)}$$

$$= \frac{-e^{-t} + e^{-t} - 0 - 9}{D^2 + D + 5D + 5 - (2D^2 + 6D + D + 3)} = \frac{-9}{-D^2 - D + 2} = \frac{9}{D^2 + D - 2},$$

or $(D^2 + D - 2)x = 9$. (Non-homogeneous linear ODE with constant coefficients)

$$m^2 + m - 2 = 0 \Rightarrow (m + 2)(m - 1) = 0 \Rightarrow m_1 = -2 \text{ and } m_2 = 1.$$

$$\therefore x_c = C_1 e^{-2t} + C_2 e^t.$$

Let $x_p = A_o \Rightarrow x'_p = 0 = x''_p$.

Substituting,

$$0 + 0 - 2A_o = 9 \Rightarrow A_o = -9/2 \Rightarrow x_p = -9/2.$$

$$x = x_c + x_p \Rightarrow x = C_1 e^{-2t} + C_2 e^t - \frac{9}{2}.$$

Similarly,

$$y = \frac{\begin{vmatrix} D+5 & e^{-t} \\ 2D+1 & 3 \end{vmatrix}}{\begin{vmatrix} D+5 & D+3 \\ 2D+1 & D+1 \end{vmatrix}} = \frac{(D+5)(3) - (2D+1)e^{-t}}{-D^2 - D + 2}$$

$$= \frac{0 + 15 + 2e^{-t} - e^{-t}}{-D^2 - D + 2} = \frac{15 + e^{-t}}{-D^2 - D + 2} = \frac{-15 - e^{-t}}{D^2 + D - 2},$$

Or $(D^2 + D - 2)y = -e^{-t} - 15$. (Non-homogeneous LODE with constant coeffs.)

$$m^2 + m - 2 = 0 \quad \Rightarrow \quad (m+2)(m-1) = 0 \quad \Rightarrow \quad m_1 = -2 \quad \text{and} \quad m_2 = 1.$$

$$\therefore y_c = C_3 e^{-2t} + C_4 e^t.$$

$$\text{Let } y_p = A_1 + A_2 e^{-t} \quad \Rightarrow \quad y'_p = -A_2 e^{-t} \quad \Rightarrow \quad y''_p = A_2 e^{-t}.$$

Substituting,

$$A_2 e^{-t} - A_2 e^{-t} - 2(A_1 + A_2 e^{-t}) = -e^{-t} - 15 \quad \Rightarrow \quad -2A_1 - 2A_2 e^{-t} = -e^{-t} - 15.$$

$$\therefore -2A_1 = -15 \quad \Rightarrow \quad A_1 = 15/2,$$

$$-2A_2 = -1 \quad \Rightarrow \quad A_2 = 1/2,$$

$$\therefore y_p = \frac{1}{2} e^{-t} + \frac{15}{2}.$$

$$y = y_c + y_p \quad \Rightarrow \quad y = C_3 e^{-2t} + C_4 e^t + \frac{1}{2} e^{-t} + \frac{15}{2}.$$

Substituting x and y in Eq. (1) gives,

$$-2C_1 e^{-2t} + C_2 e^t + 5(C_1 e^{-2t} + C_2 e^t - \frac{9}{2}) - 2C_3 e^{-2t} + C_4 e^t - \frac{1}{2} e^{-t} + 3(C_3 e^{-2t} + C_4 e^t + \frac{1}{2} e^{-t} + \frac{15}{2}) = e^{-t}.$$

$$(3C_1 + C_3) e^{-2t} + (6C_2 + 4C_4) e^t - \frac{45}{2} + \frac{45}{2} + e^{-t} = e^{-t}.$$

$$\therefore 3C_1 + C_3 = 0 \quad \Rightarrow \quad C_3 = -3C_1,$$

$$6C_2 + 4C_4 = 0 \quad \Rightarrow \quad C_4 = -\frac{3}{2} C_2.$$

$$\therefore x = C_1 e^{-2t} + C_2 e^t - \frac{9}{2} \quad \text{and} \quad y = -3C_1 e^{-2t} - \frac{3}{2} C_2 e^t + \frac{1}{2} e^{-t} + \frac{15}{2}. \quad (\text{G.S})$$