Theory of Structures

Analysis of Structures

Course contents

- 1- Introduction
- 2- Internal loading developed in structural members
- 3- Analysis of statically determinate trusses
- 4- Influence lines for statically determinate structures
- 5- Deflections
- 6- Force methods
- 7- Displacement methods: Slope-deflection equation.
- 8- Displacement methods: Moment Distribution.
- 9- Energy methods

References

- 1- Elementary Theory of Structures, Yan-Yu Hsieh
- 2- Structural Analysis, RC. Hibbeler

Chapter One

Introduction

A "Structures" refers to a system of connected parts used to support a load. Important examples related to civil engineering include buildings, bridges, and towers. In other branches of engineering such as ships, aircraft frames, tanks and pressure vessels, mechanical systems, and electrical supporting structures are Important.

Types of structural elements

1- Ties: These are structural members that are subjected to axial tension only.

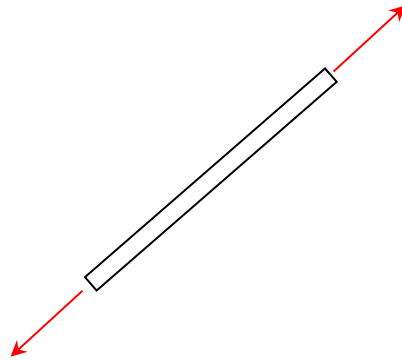

2- Struts (Columns): These are structural members that are subjected to axial compression only.

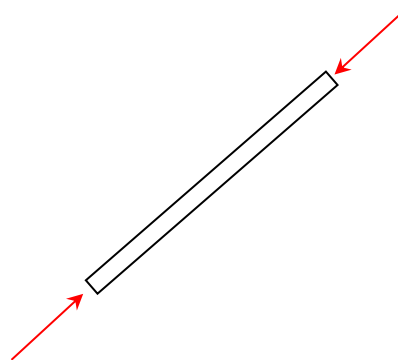

3- Beams: These are usually straight horizontal members subjected to transverse loading and hence to bending moment and shear force at each normal section.

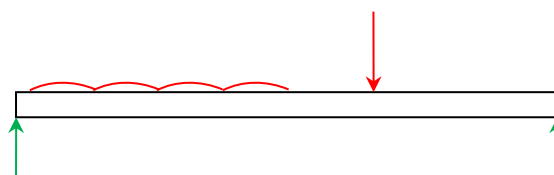

Types of structures

- 1- Trusses: these are structures which consist of members which are pin-connected at each terminal. These members usually form one or more triangles in a single plan and are so arranged that the external loads at the joints and hence each member is subjected to direct force and is a tie or a strut.

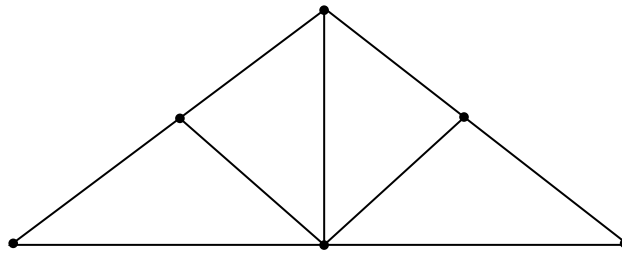

- 2- Frames: These are structures which have moment-resisting joints. The members are rigidly connected at their ends so that no joint translation is possible (i. e. the members at a joint may rotate as a group but may not move with respect to each other). The members are subjected to axial and lateral loadings and hence to shear force, bending moments and axial load at each normal section.

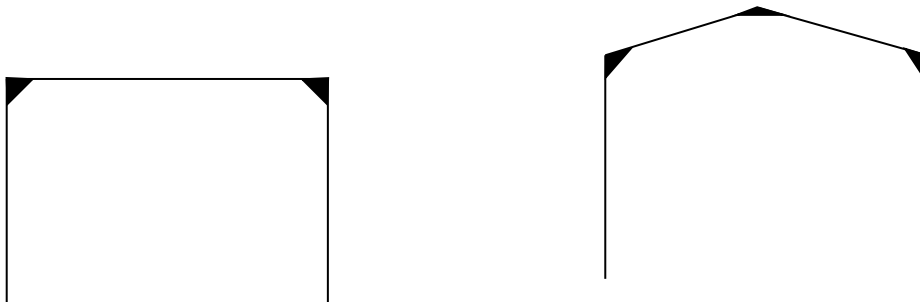

- 3- Cables: These structures use in cases of long spans distances, such as bridges where they are always in tension.



- 4- Arches: As in the case of cables, this type of structures uses in cases of long spans distances but achieve their strength in compression, since it has a reverse curvature to that of the cable. The arch must be rigid, however, in order to maintain its shape, and this results in secondary loadings involving shear and moment, which must be considered in its design.



Types of loads

Loads can be classified as being "dead loads" and "live loads".

- 1- **Dead loads:** these are loads of constant magnitude that remain in one position. They consist of the structural frames own weight and other loads that are permanently attached to the frame. For a steel-frame building, some dead loads include the frame, walls, and floor.
- 2- **Live loads:** live loads are loads that may change in position and magnitude. Live loads that move under their own power are said to be "moving loads", such as tracks, people, and cranes whereas those loads that may be moved are movable loads such as furniture, goods, and snow. Examples of live loads to be considered include: traffic loads for bridges, **Impact loads**.

Types of supports

Structures may be supported by hinges, rollers, fixed ends, or links;

- 1- A "**hinge**" or pin-type support prevents movement in the horizontal and vertical direction but does not prevent rotation about the hinge. There are two unknown forces at a hinge.

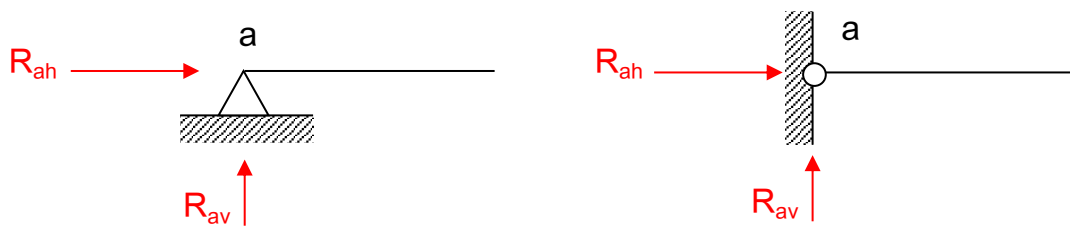

2- A **"roller"** type of support is assumed to offer resistance to movement only in a direction perpendicular to the supporting surface beneath the roller. There is no resistance to rotation about the roller or to movement parallel to the supporting surface. The magnitude of the force required to prevent movement perpendicular to the supporting surface is the one unknown.

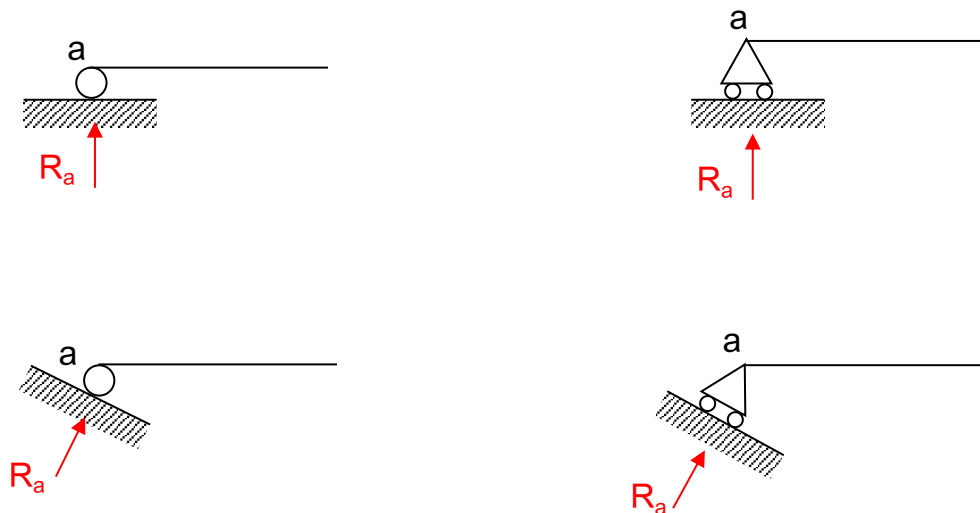

3- A **"fixed"** support is assumed to offer resistance to rotation about the support and to movement vertically and horizontally. There are three unknowns.

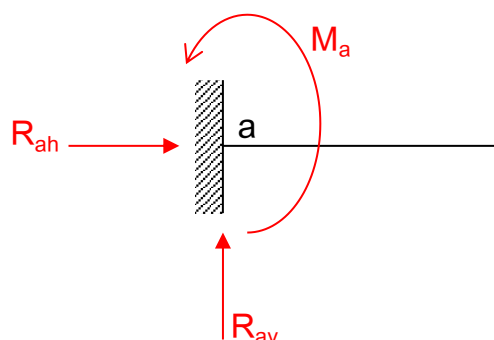

- 4- A "link" type of support is similar to the roller in its action. The line of action of the supporting force must be in the direction of the link and through the two pins. One unknown is present: the magnitude of the force in the direction of the link.



Equations of Equilibrium

The equations of equilibrium for a force system in the xy-plane are;

$$\sum F_x = 0 \qquad \sum F_y = 0 \qquad \sum M_z = 0$$

The third equation is the algebraic sum of the moments of all the forces about z-axis and passes through some arbitrary point O. For complete equilibrium in two dimensions, all three of the independent equations must be satisfied.

The equilibrium equations can also be expressed in three alternative forms;

$$\begin{array}{lll} \sum F_x = 0 & \sum M_a = 0 & \sum M_b = 0 \\ \sum F_y = 0 & \sum M_a = 0 & \sum M_b = 0 \\ \sum M_a = 0 & \sum M_b = 0 & \sum M_c = 0 \end{array}$$

where the points a, b, and c are not lay on the same line

Example (1): Calculate the reactions for the beam shown.

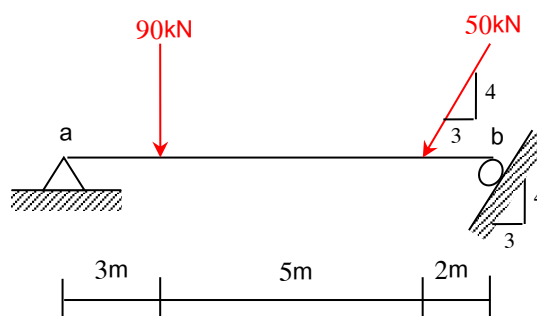

Solution (1)

$$\sum M_b = 0 \Rightarrow 10R_{ay} - 40 \times 2 - 90 \times 7 = 0$$

$$R_{ay} = 71 \text{ kN } (\uparrow)$$

$$\sum F_y = 0 \Rightarrow \frac{3}{5} R_b + 71 - 90 - 40 = 0$$

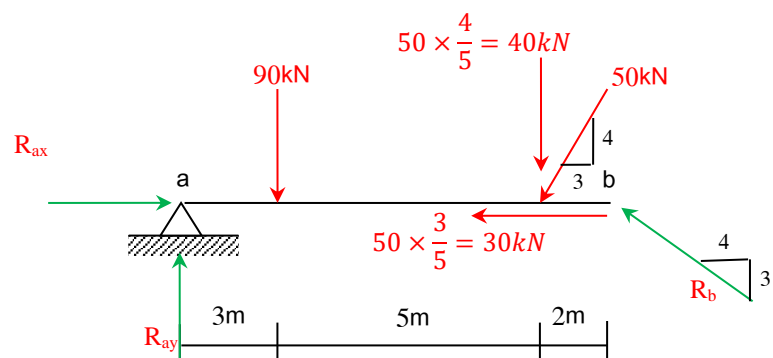

$$R_b = 98.33\text{kN} (\nearrow)$$

$$\sum F_x = 0 \Rightarrow R_{ax} - 30 - \frac{4}{5} R_b = 0$$

$$R_{ax} - 30 - \frac{4}{5} \times 98.33 = 0$$

$$R_{ax} = 108.66\text{kN} (\rightarrow)$$

Solution (2)

$$\sum M_b = 0 \Rightarrow R_{ay} = 71\text{kN} (\uparrow)$$

$$\sum M_a = 0 \Rightarrow 90 \times 3 + 40 \times 8 - 10 (R_b \times \frac{3}{5}) = 0$$

$$R_b = 98.33\text{kN} (\nearrow)$$

$$\sum F_x = 0 \Rightarrow R_{ax} = 108.66\text{kN} (\rightarrow)$$

Solution (3)

$$\sum M_c = 0 \Rightarrow$$

$$90 \times 3 + 40 \times 8 + 30 \times 7.5 - R_{ax} \times 7.5 = 0$$

$$R_{ax} = 108.66\text{kN} (\rightarrow)$$

Point C is the intersection of R_{ay} and R_b and not lay on the line ab.

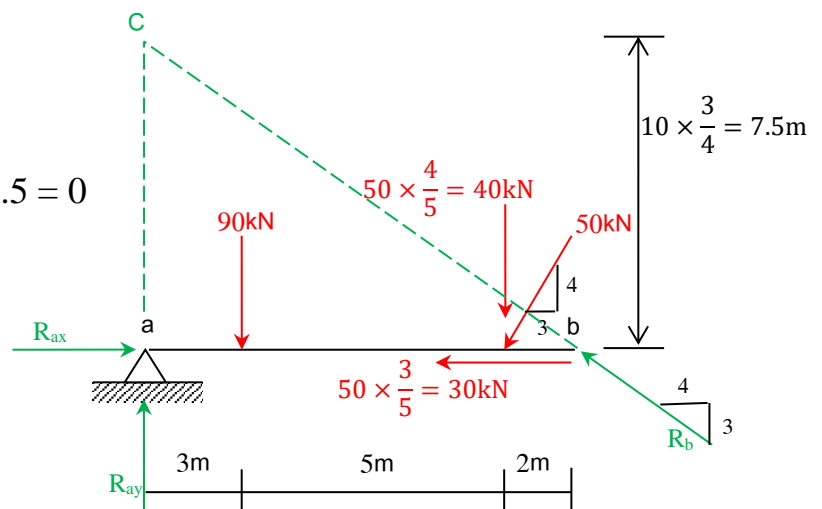

Determinacy and Stability

Determinacy

The equilibrium equations provide both the "necessary and sufficient" conditions for equilibrium when all the forces in a structure can be determined from these equations, the structure is referred to as "*statically determinate*". Structures having more unknown forces than available equilibrium equations are called "*statically indeterminate*". For a coplanar structure there are at most "*three*" equilibrium equations for each part, so that if there is a total of " *n* " parts and " *r* " internal force and moment reaction components, we have;

$$\left(\begin{array}{l} r = 3n \text{ ,statically determinate} \\ r > 3n \text{ ,statically indeterminate} \\ r < 3n \text{ , unstable} \end{array} \right) \text{----- Eq. (1)}$$

The above equation used for beams and frames.

At the same time, we can use the equations of conditions to find the indeterminacy of *beams as bellow*;

$$\left(\begin{array}{l} R = 3+c \text{ , statically determinate} \\ R > 3+c \text{ , statically indeterminate} \\ R < 3+c \text{ , unstable} \end{array} \right) \text{----- Eq. (2)}$$

where R: No. of reactions.
 3: No. of equations of equilibrium.
 c: No of equations of conditions.

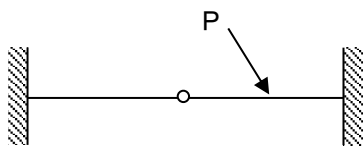

By using Eq. 1

$$r = 8, n = 2$$

$$8 > 3(2)$$

$8 > 6$ *statically indeterminate to the second degree*

Or by using Eq. 2

$$R = 6, c = 1$$

$$6 > 3+1$$

$6 > 4$ *statically indeterminate to the second degree*

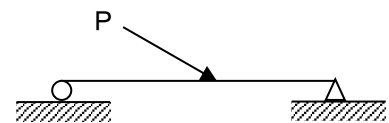

By using Eq. 1

$$r = 3, n = 1$$

$$3 = 3(1)$$

$$3 = 3(1)$$

statically determinate

Or by using Eq. 2

$$R = 3, c = 0$$

$$3 = 3+0$$

$3 = 3$ *statically determinate*

In the presence of equations of condition in frames, we can use the Eq. (3) to find the determinacy as bellow,

$$\left(\begin{array}{l} 3m+R = 3j+c \text{ ,statically determinate} \\ 3m+R > 3j+c \text{ ,statically indeterminate} \\ 3m+R < 3j+c \text{ ,unstable} \end{array} \right) \text{----- Eq. (3)}$$

Where m: No. of members

j: No. of joints

c: No of equations of conditions and equals to i-1, where i is the number of members meeting at that joint

In particular if a structure is statically indeterminate, additional equations needed to solve.

Stability

A structure will become "*unstable*"(i.e. it will move slightly or collapse) if there are fewer reactive forces than available equations (*Equations of equilibrium and conditions if any*).

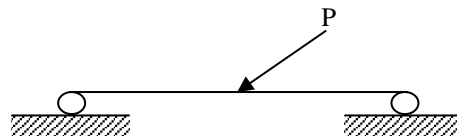

$$r = 2, n = 1$$

$$2 < 3(1) \text{ Unstable}$$

If there are enough reactions, instability will occur if the lines of action of the reactive forces intersect at a common point, or are parallel to one another (*Geometric instability*). The geometric instability may be occurred in the case of incorrect arrangement of members and supports.

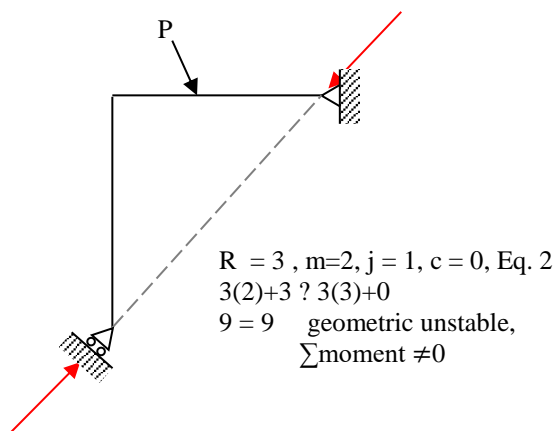

$$R = 3, m=2, j = 1, c = 0, \text{ Eq. 2}$$

$$3(2)+3 \neq 3(3)+0$$

$$9 = 9 \text{ geometric unstable,}$$

$$\sum \text{moment} \neq 0$$

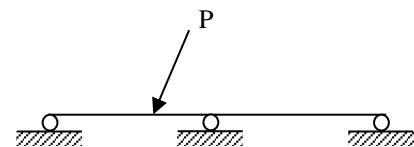

$$r = 3, n = 1, \text{ Eq. 1}$$

$$3 \neq 3(1)$$

$$3 = 3 \text{ geometric unstable due}$$

$$\text{to parallel reaction}$$

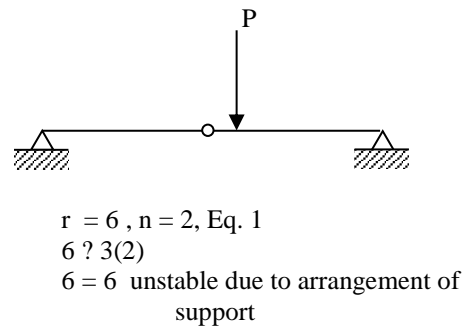
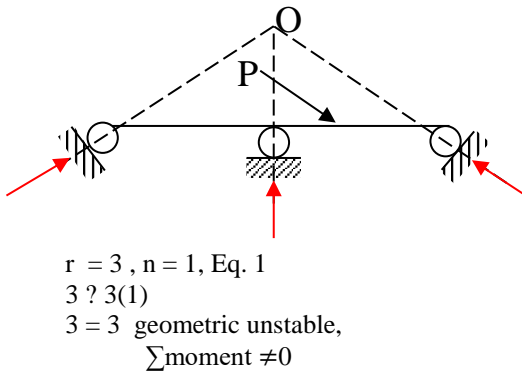

Example (1): Classify each of the beams shown in figure as statically determinate or statically indeterminate.

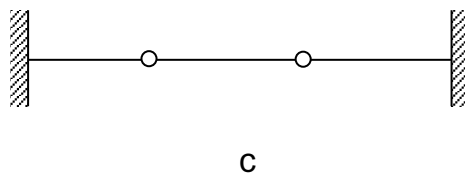
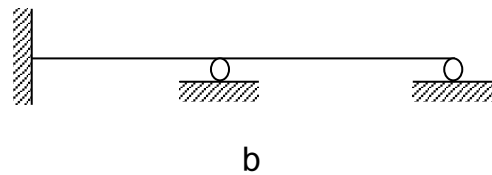
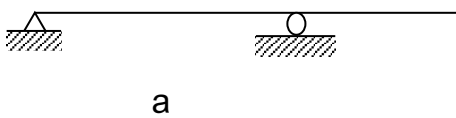

Solution

a- Using Eq. (1) $\Rightarrow r \neq 3n, r = 3, n = 1$

$$3 \neq 3(1)$$

$$3 = 3 \text{ Statically determinate}$$

Using Eq. (2) $\Rightarrow R \neq 3 + C, R = 3, C = 0$

$$3 \neq 3 + 0$$

$$3 = 3 \text{ Statically determinate}$$

b- Using Eq. (1) $\Rightarrow r \neq 3n, r = 5, n = 1$

$$5 \neq 3(1)$$

$$5 > 3 \text{ Statically indeterminate to the 2}^{\text{nd}} \text{ degree}$$

Using Eq. (2) $\Rightarrow R = 3 + C, R = 3, C = 0$

$$5 \neq 3 + 0$$

$$5 > 3 \text{ Statically indeterminate to the 2}^{\text{nd}} \text{ degree}$$

c- Using Eq. (1) $\Rightarrow r = 3n, r = 10, n = 3$

$$10 \neq 3(3)$$

$$10 > 9 \text{ Statically indeterminate to the 1}^{\text{st}} \text{ degree}$$

Using Eq. (2) $\Rightarrow R = 3 + C, R = 6, C = 2$

$$6 \neq 3 + 2$$

$$6 > 5 \text{ Statically indeterminate to the 1}^{\text{st}} \text{ degree}$$

Example (2): Classify each of the pin-connected structures as statically determinate or statically indeterminate.

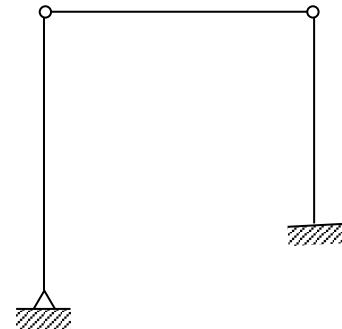
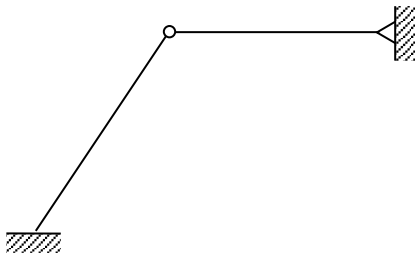

Solution

a- Using Eq. (1) $\Rightarrow r = 3n, r = 7, n = 2$

$$7 \neq 3(2)$$

$$7 > 6 \text{ Statically indeterminate to the 1}^{\text{st}} \text{ degree}$$

Using Eq. (3) $\Rightarrow 3m + R = 3j + C, R = 5, j = 3, m = 2, C = 1$

$$3 \times 2 + 5 \neq 3 \times 3 + 1$$

$$11 > 10 \text{ Statically indeterminate to the 1}^{\text{st}} \text{ degree}$$

b- Using Eq. (1) $\Rightarrow r \geq 3n$, $r = 9$, $n = 3$

$$9 \geq 3(3)$$

$$9 = 9 \text{ Statically determinate}$$

Using Eq. (3) $\Rightarrow 3m + R \geq 3j + C$, $R = 5$, $j = 4$, $m = 3$, $C = 2$

$$3 \times 3 + 5 \geq 3 \times 4 + 2$$

$$14 = 14 \text{ Statically determinate}$$

Example (3): Classify each of frames shown as statically determinate or statically indeterminate.

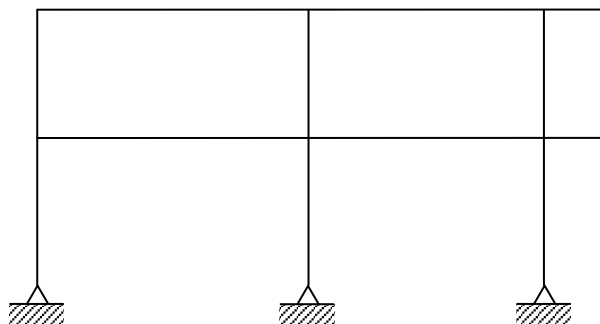
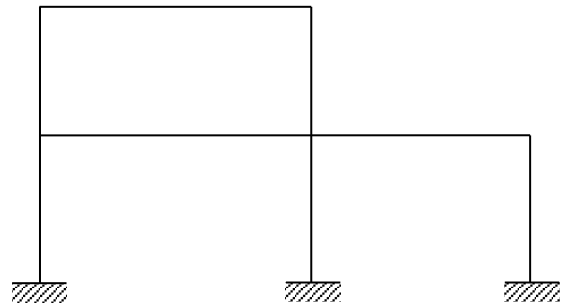
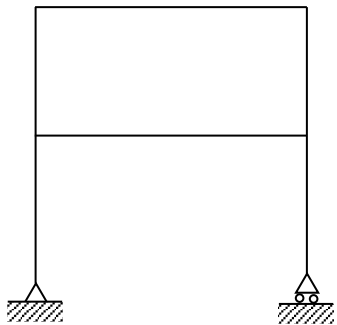

Chapter Two

Internal Loadings Developed in Structural Members

The internal load at a specified point in a member can be determined by using the "*method of sections*". In general, this loading for a coplanar structure will consist of a normal force " N ", shear force " V ", and bending moment " M ". Once the resultant of internal loadings at any section are known, the magnitude of the induced stress on that section can be determined.

Sign Convention

On the "left-hand face" of the cut member in Fig. (a), the normal force " N " acts to the right, the internal shear force " V " acts downward, and the moment " M " acts counterclockwise. In accordance with Newton's third law, an equal but opposite normal force, shear force, and bending moment must act on the right-hand face of the member at the section.

Isolate a small segment of the member; positive normal force tends to elongate the segment, Fig. (b); positive shear tends to rotate the segment clockwise, Fig. (c); and positive bending moment tends to bend the segment concave upward, Fig. (d).

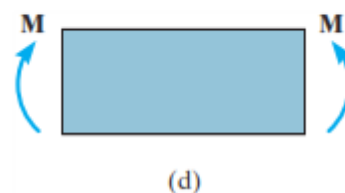
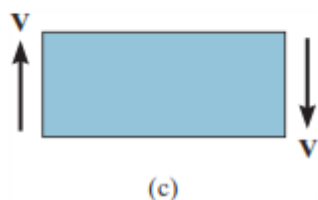
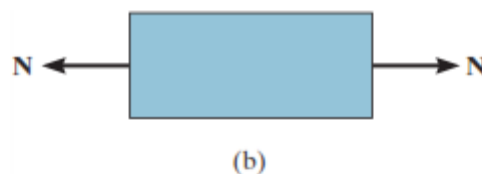
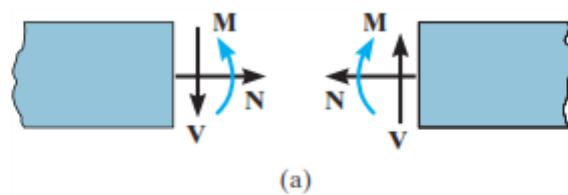

Shear Force and Bending Moment Diagrams for a Beam

Plots showing the variations of V and M along the length of a beam are termed; *Shear Forces Diagram (SFD) and Bending Moment Diagram (BMD)*, respectively.

Relationships between Load, Shear Force and Bending Moment

Consider the beam AD , shown in Fig. (a), which is subjected to an arbitrary distributed loading $w = w(x)$. The distributed load is considered positive when the loading acts upward.

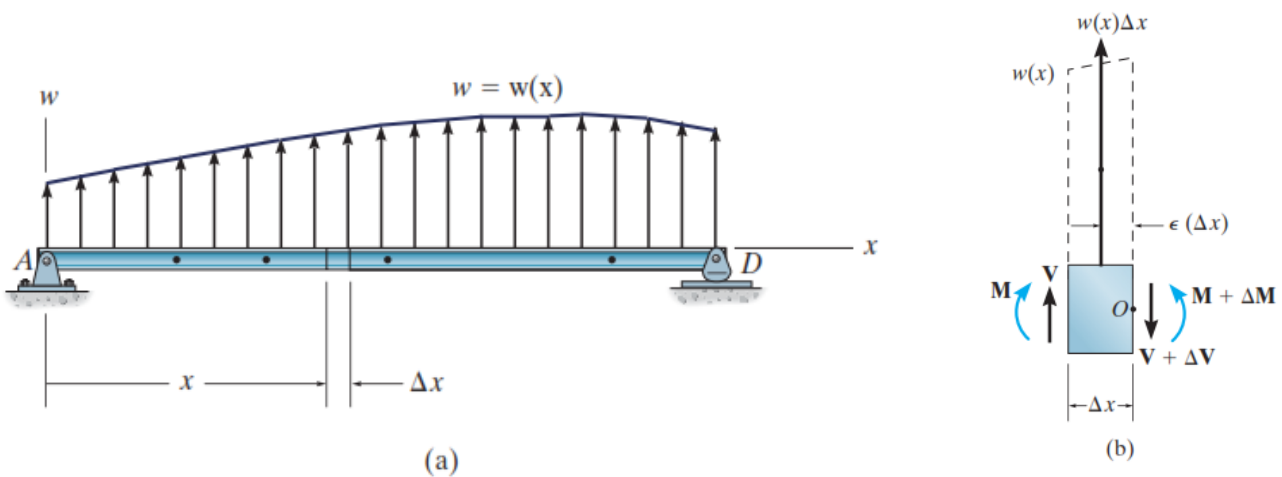

Applying the equations of equilibrium for the free-body diagram of a small segment of the beam having a length Δx .

$$\sum F_y = 0; \quad V + w(x).\Delta x - (V + \Delta V) = 0$$

$$\Delta V = w(x).\Delta x$$

$$\sum M_O = 0; \quad -V.\Delta x - M - w(x).\frac{(\Delta x)^2}{2} + (M + \Delta M) = 0$$

Since the term $w(x).\frac{(\Delta x)^2}{2}$ is very small and can be neglected;

$$\text{So, } \Delta M = V.\Delta x$$

Taking the limit as $\Delta x \rightarrow 0$;

$$\frac{dV}{dx} = w(x) \quad \text{----- (2.1)}$$

$$\frac{dM}{dx} = V \quad \text{----- (2.2)}$$

Equation (2.1) states that "the slope of the shear diagram at a point ($\frac{dV}{dx}$) is equal to the intensity of the distributed load $w(x)$ at that point".

Likewise, Eq. (2.2) states that "the slope of the moment diagram ($\frac{dM}{dx}$) is equal to the intensity of the shear at that point".

From one point to another, in which case;

$$\Delta V = \int w(x). dx \quad \text{----- (2.3)}$$

$$\Delta M = \int V(x). dx \quad \text{----- (2.4)}$$

Equation (2.3) states that "the change in the shear between any two points on a beam equals the area under the distributed loading diagram between those two points".

Likewise, Eq. (2.4) states that "the change in the moment between any two points on a beam equals the area under the shear diagram between those two points".

Example (1): Draw the shear force and bending moment diagrams for the simply supported beam subjected to a concentrated load as shown in the figure below.

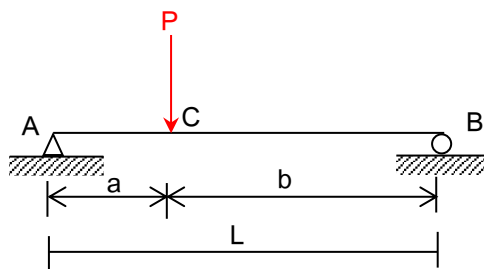

Solution

$$\sum M_B = 0 \Rightarrow R_A = \frac{Pb}{L}$$

$$\sum M_A = 0 \Rightarrow R_B = \frac{Pa}{L}$$

S.F.D

For $0 < x < a$

$$V_x = R_A = \frac{Pb}{L}$$

For $a < x < L$

$$V_x = R_A - P = \frac{Pb}{L} - P = P \left(\frac{b-L}{L} \right) = -\frac{Pa}{L} = -R_B$$

B.M.D

For $0 \leq x \leq a$

$$M_x = R_A \cdot x = \frac{Pb}{L} \cdot x$$

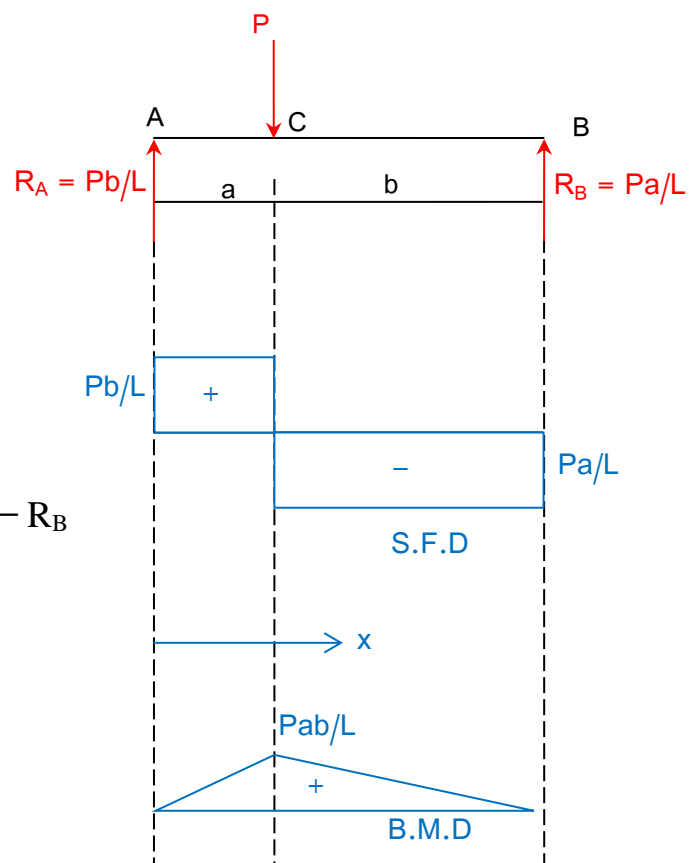

For $a < x \leq L$

$$\begin{aligned} M_x &= R_A \cdot x - P(x - a) = \frac{Pb}{L} \cdot x - P \cdot x + P \cdot a = x \cdot P \left(\frac{b}{L} - 1 \right) + P \cdot a \\ &= x \cdot P \left(\frac{-a}{L} \right) + P \cdot a = P \cdot a \left(\frac{-x}{L} + 1 \right) \\ &= \frac{P \cdot a}{L} (L - x) = R_B (L - x) \end{aligned}$$

Example (2): Draw the shear force and bending moment diagrams for the simply supported beam subjected to a uniformly distributed load of intensity " ω ", as shown in the figure below.

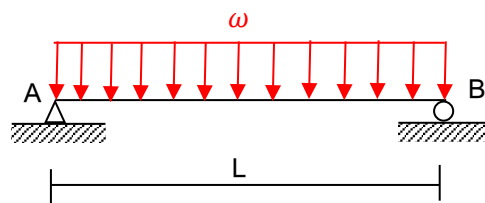

Solution

$$\sum M_B = 0 \Rightarrow R_A \cdot L = \frac{\omega \cdot L^2}{2}$$

$$R_A = \frac{\omega \cdot L}{2} = R_B$$

S.F.D

$$V_x = R_A - \omega \cdot x$$

$$V_x = \frac{\omega \cdot L}{2} - \omega \cdot x$$

B.M.D

$$M_x = R_A \cdot x - \frac{\omega \cdot x^2}{2}$$

$$M_x = \frac{\omega \cdot L}{2} \cdot x - \frac{\omega \cdot x^2}{2}$$

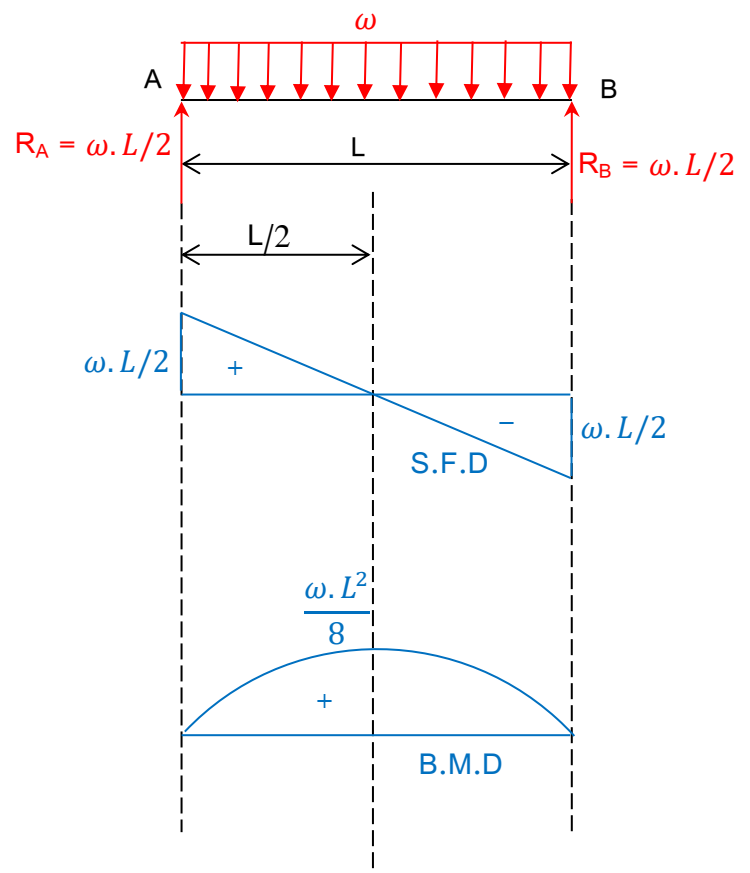

Example (3): Draw the shear force and bending moment diagrams for the simply supported beam subjected to a concentrated moment as shown in the figure below.

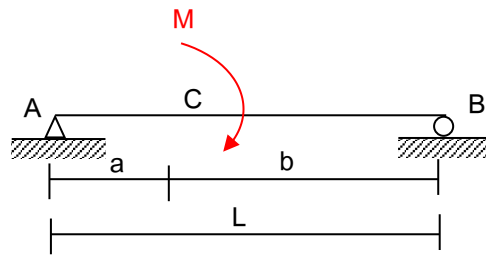

Solution

$$\sum M_B = 0 \Rightarrow -R_A \cdot L + M = 0$$

$$R_A = \frac{M}{L}$$

$$\sum M_A = 0 \Rightarrow R_B \cdot L - M = 0$$

$$R_B = \frac{M}{L}$$

S.F.D

For $0 \leq x \leq L$

$$V_x = -R_A = -\frac{M}{L}$$

B.M.D

For $0 \leq x \leq a$

$$M_x = -R_A \cdot x = -\frac{M}{L} \cdot x$$

$$\therefore M_A = 0, \quad M_C = -\frac{M \cdot a}{L}$$

For $a < x \leq L$

$$M_x = -R_A \cdot x + M = -\frac{M}{L} \cdot x + M$$

$$= \frac{M}{L} (L - x) = R_B (L - x)$$

$$\therefore M_C = \frac{M \cdot b}{L}, \quad M_B = 0$$

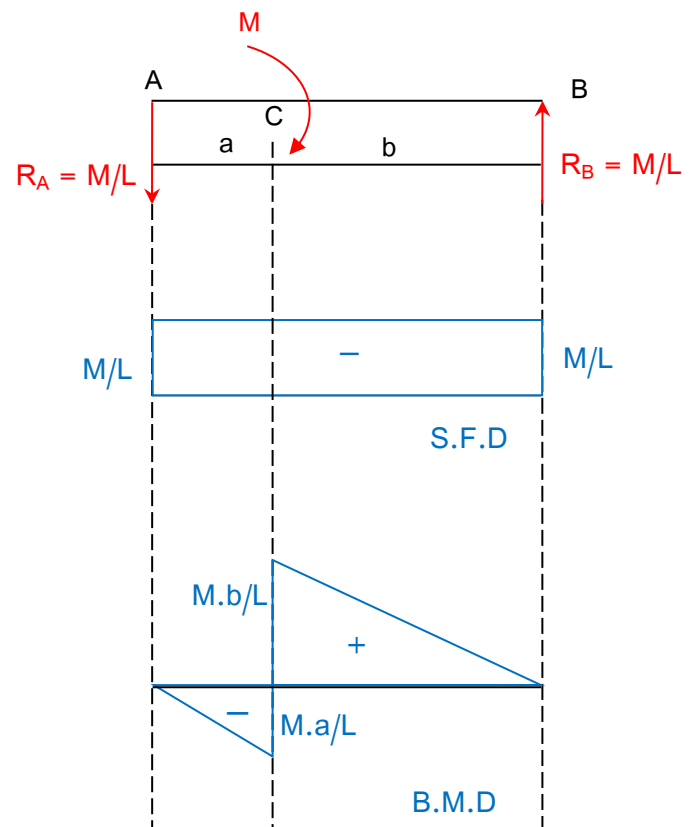

Moment Diagrams by the Method of Superposition

Using the principle of superposition, each of the loads can be treated separately and the moment diagram can then be constructed in a series of parts rather than a single and sometimes complicated shape. This can be particularly useful when applying geometric deflection methods to determine both the deflection of a beam and the reactions on a statically indeterminate beams.

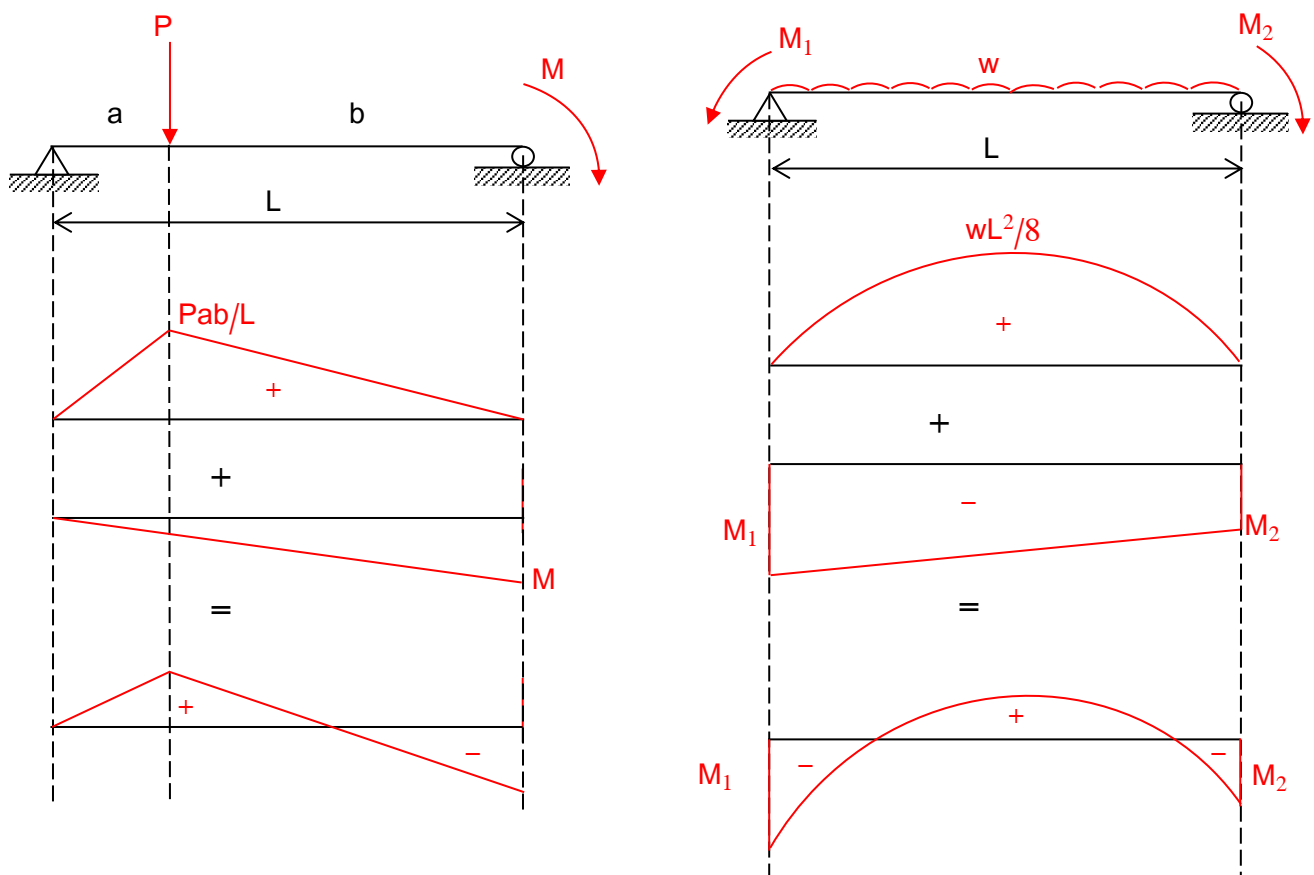

Shear and Moment Diagrams for a Frame

To draw the shear force and bending moment diagrams for a frame, it is first required to determine the reactions at the frame supports. Then, using the method of sections, we find the axial force, shear force, and moment acting at the ends of each member. All the loadings are resolved into components acting parallel and perpendicular to the member's axis.

The sign convention followed will be to draw the bending moment diagram positive on the compression side of the member

Example (1): The frame shown in the figure is pinned at a and supported on a roller at d. For the loading indicated:

- i- Determine the support reactions.
- ii- Draw the axial load, shear force, and bending moment diagrams.

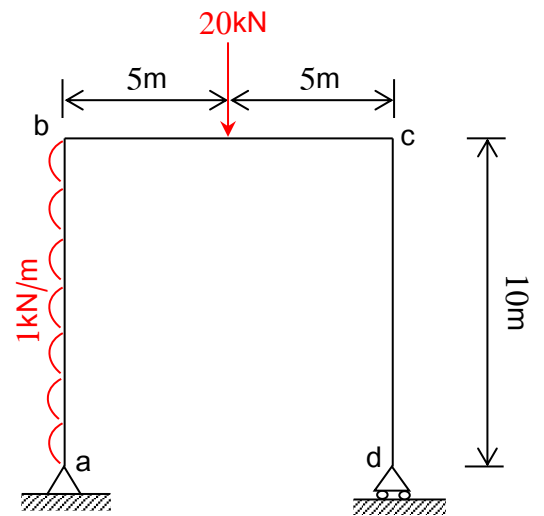

Solution

i- Applying the equations of equilibrium;

$$\sum M_a = V_d \times 10 - 20 \times 5 - \frac{1 \times 10^2}{2} = 0$$

$$V_d = 15 \text{ kN } (\uparrow)$$

$$\sum F_y = V_a + V_d - 20 = 0$$

$$15 + V_a - 20 = 0 \Rightarrow V_a = 5 \text{ kN } (\uparrow)$$

$$\sum F_x = H_a - 1 \times 10 = 0 \Rightarrow H_a = 10 \text{ kN } (\leftarrow)$$

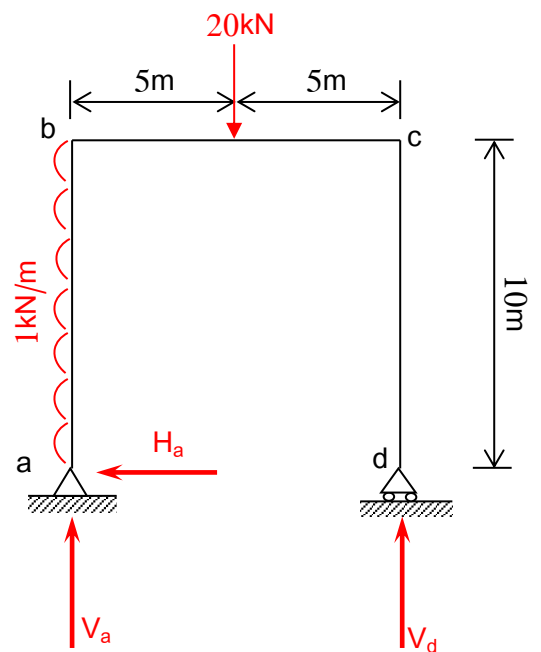

ii-

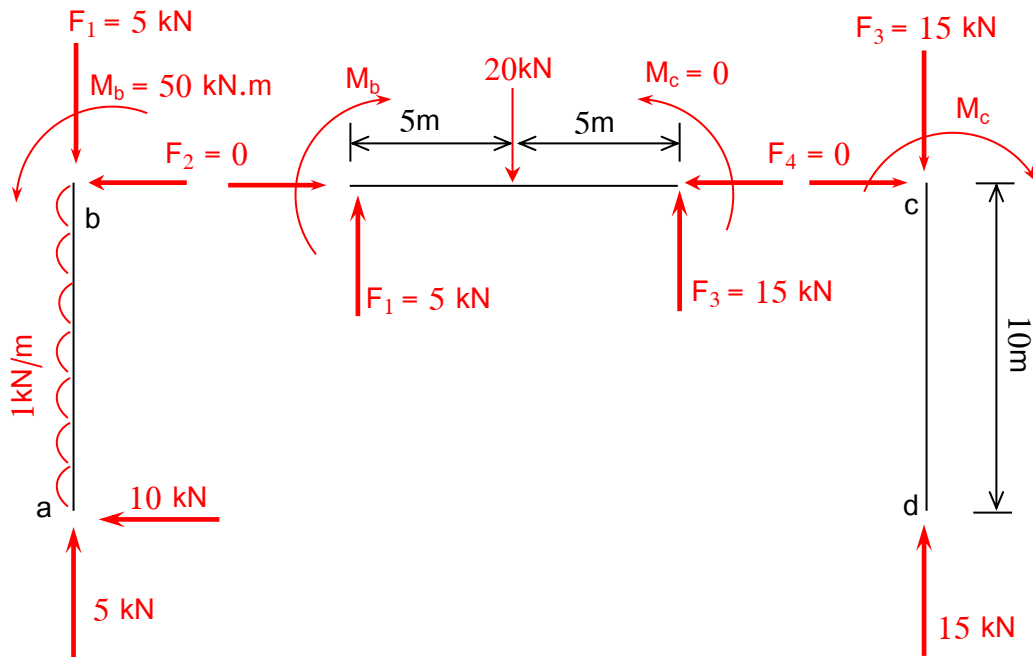

For member ab ; $\sum F_y = 5 - F_1 = 0 \Rightarrow F_1 = 5 \text{ kN } (\uparrow)$

$$\sum F_x = 1 \times 10 - 10 - F_2 = 0 \Rightarrow F_2 = 0$$

$$\sum M_a = \frac{1 \times 10^2}{2} - M_b = 0 \Rightarrow M_b = 50 \text{ kN.m } (\curvearrowright)$$

For member bc ; $\sum F_y = 5 - 20 + F_3 = 0 \Rightarrow F_3 = 15 \text{ kN } (\uparrow)$

$$\sum F_x = 0 - F_4 = 0 \Rightarrow F_4 = 0$$

$$\sum M_c = 5 \times 10 + 50 - 20 \times 5 - M_c = 0 \Rightarrow M_c = 0$$

For member cd ; $\sum F_y = 15 - 15 = 0$, $\sum F_x = 0$, and $\sum M_c = 0$ ok

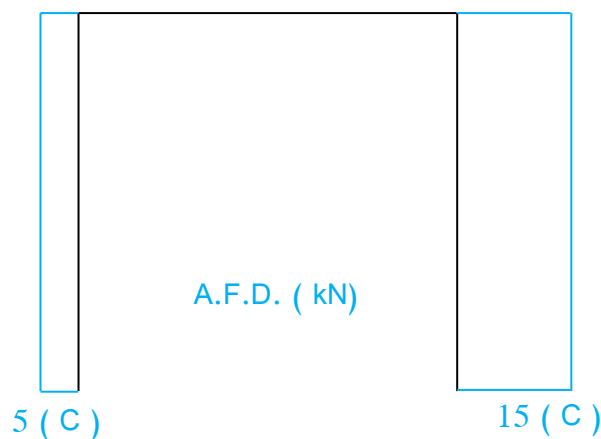

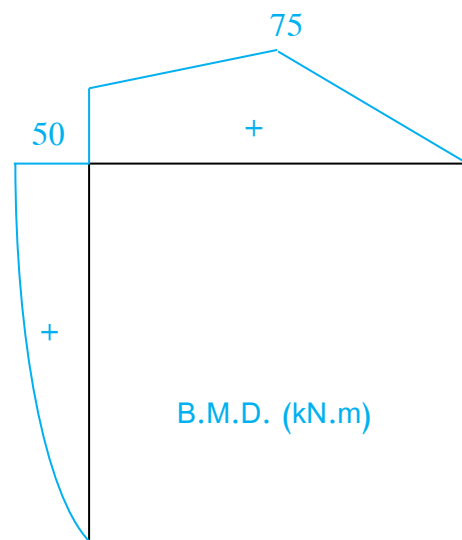
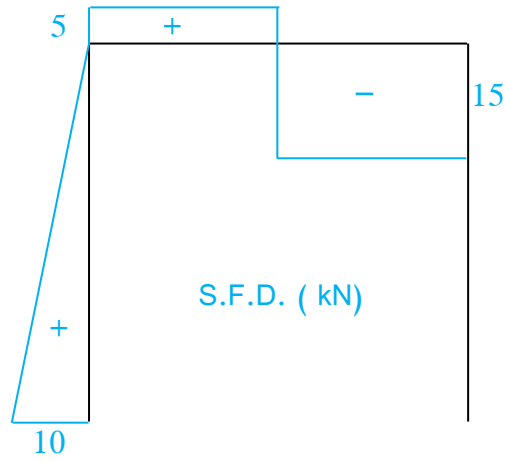

Example (2): Determine the support reactions and draw the axial force, shear force, and bending moment diagrams for the frame shown in the figure below.

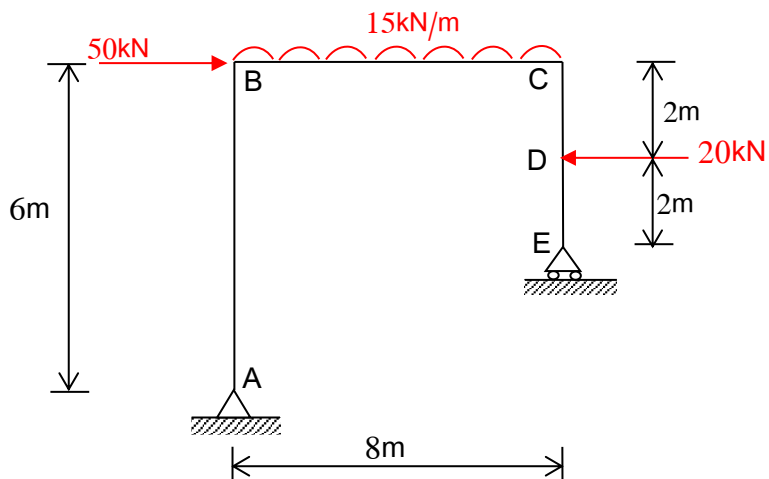

Chapter Three

Analysis of Statically Determinate Trusses

A truss is defined as a structure formed by group of members arranged in the shape of one or more triangles.

Because the members are assumed to be connected with frictionless pins, the triangle is the only stable shape. Figures of the four or more sides are not stable and may collapse under load.

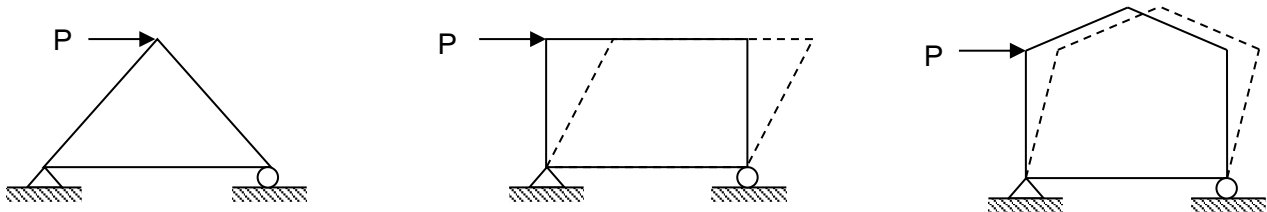

Assumptions for Truss analysis:

- 1- Truss members are connected together with frictionless pins.
- 2- Truss members are straight.
- 3- The deformations of truss under load are of small magnitude and do not cause changes in the overall shape and dimensions of the truss.
- 4- Members are so arranged that the loads and reactions are applied only at the truss joints.

Determinacy and Stability of Trusses

For any problem in truss analysis, the total member of unknowns equals $(b+r)$, where;

b : is the forces in the bars and

r : is number of external reactions.

Since the members are all straight axial force members lying in the same plane, the force system acting at each joint is "**Coplanar and concurrent**". Consequently, rotational or moment equilibrium is automatically satisfied at each joint and it is only necessary to satisfy $\sum F_x = 0$ and $\sum F_y = 0$ to insure translational or force equilibrium. Therefore, only two

Theory of Structures

equations of equilibrium can be written for each joint, and if there are " j " numbers of joints, the total number of equations available for solution are " 2j ".

By comparing the total number unknowns (b + r) with the total number of available equilibrium equations, we have:

$$b + r = 2j \quad \text{Statically determinate}$$

$$b + r > 2j \quad \text{Statically indeterminate}$$

$$b + r < 2j \quad \text{Unstable \{Truss will collapse, since there will be an insufficient number of bars or reactions to constrain all the joints\}}$$

$$\begin{aligned} b + r &? 2j \\ 6 + 3 &? 2 \times 5 \\ 9 &= 10 \quad \text{Unstable.} \end{aligned}$$

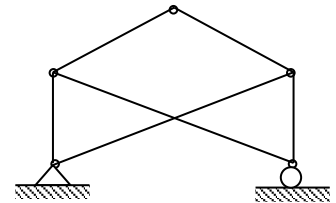

$$\begin{aligned} b + r &? 2j \\ 7 + 3 &? 2 \times 5 \\ 10 &= 10 \quad \text{Unstable \{points a, b, and c at the same line\}} \end{aligned}$$

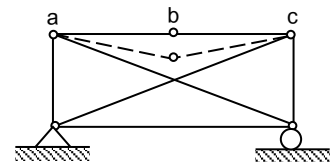

$$\begin{aligned} b + r &? 2j \\ 7 + 3 &? 2 \times 5 \\ 10 &= 10 \quad \text{Unstable \{parallel reactions\}} \end{aligned}$$

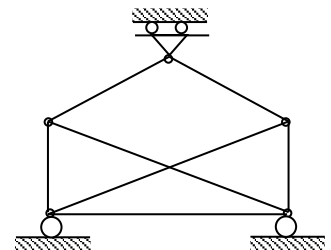

$$b + r \stackrel{?}{=} 2j$$

$$7 + 3 \stackrel{?}{=} 2 \times 5$$

$$10 = 10 \quad \text{statically determinate.}$$

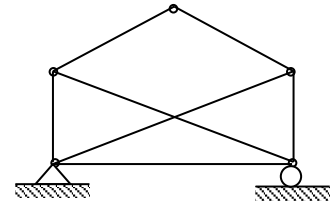

$$m + r \stackrel{?}{=} 2j$$

$$8 + 4 \stackrel{?}{=} 2 \times 5$$

$$12 > 10 \quad \text{statically indeterminate to the second degree.}$$

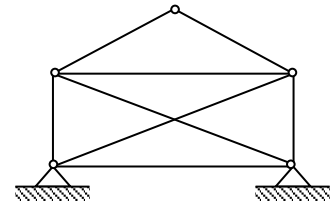

$$m + r \stackrel{?}{=} 2j$$

$$6 + 4 \stackrel{?}{=} 2 \times 5$$

$$10 > 10 \quad \text{Unstable (internal geometric instability due to the lack of lateral resistance in panel abcd)}$$

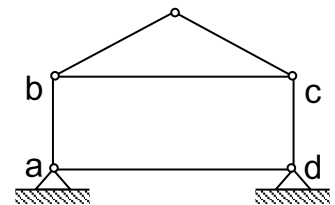

The method of Joints

If a truss is in equilibrium, then each of its joints must also be in equilibrium. Hence, the method of joints consists of satisfying the equilibrium conditions $\sum F_x = 0$ and $\sum F_y = 0$ for the forces exerted on the pin at each joint of the truss.

Special Conditions

- 1- If in any truss, there be a joint at which only three bars meet and two of these bars lies along the same straight line, then the force in the third bar is zero, provided that there is no external force applied.

$$\sum Y_i = 0 \implies F_3 = 0$$

$$\sum X_i = 0 \implies F_1 = F_2$$

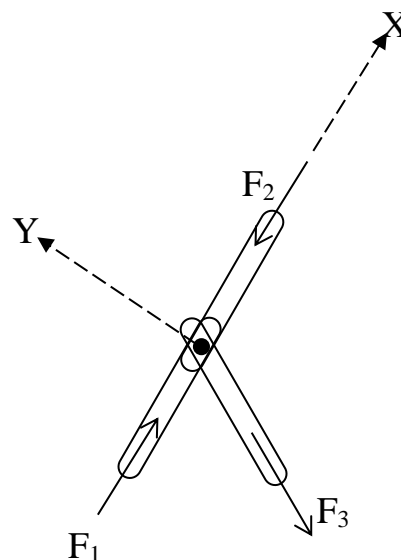

2- Since two forces can be in equilibrium only if they are equal, opposite, and collinear, we conclude that the forces in any two bars, their axes is not collinear, are equal to zero if there is no external force applied at their joint.

$$\Sigma X_i = 0 \implies F_2 = 0$$

$$\Sigma X'_i = 0 \implies F_1 = 0$$

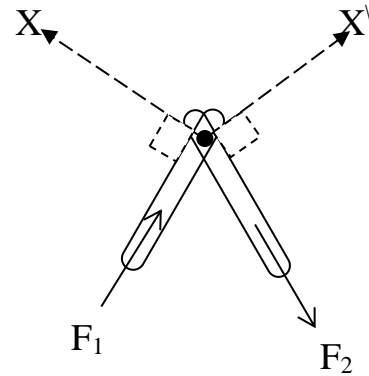

3- $\Sigma X_i = 0 \implies F_3 = F_5$

$$\Sigma X'_i = 0 \implies F_1 = F_2$$

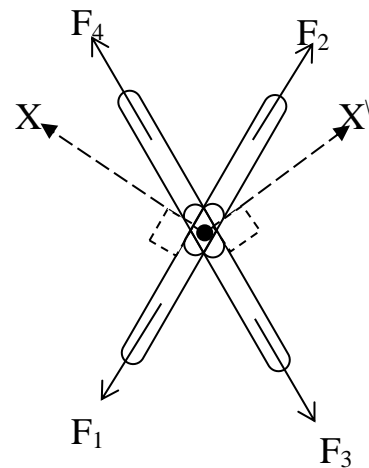

Example (1): Calculate the member forces, F_{ab} , F_{ac} , F_{bd} , F_{cd} , F_{ce} , F_{de} , and F_{df} using the method of joints.

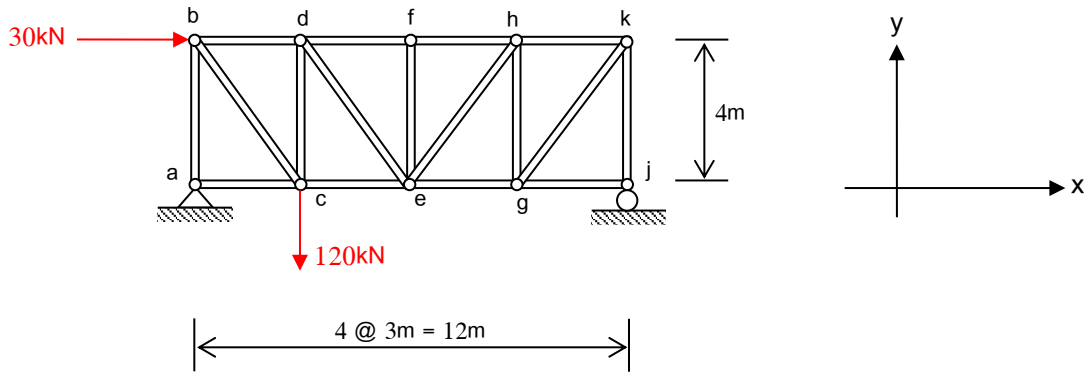

Solution

$r = 3$, $b = 17$, and $j = 10$

Then $3 + 17 = 2 \times 10$;

Hence, the truss is statically determinate, and the reactions could obtain by using the equations of equilibrium.

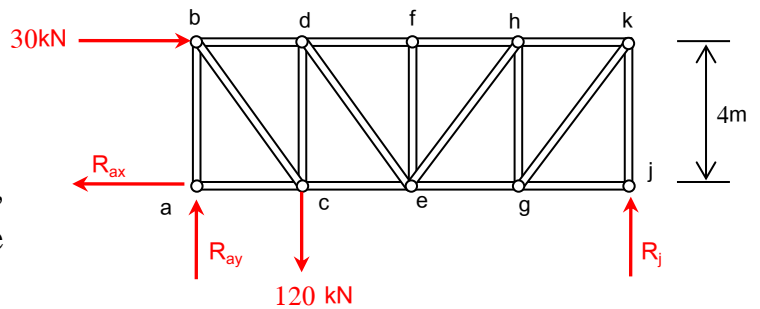

$$\sum M_a = 0 \Rightarrow 30 \times 4 + 120 \times 3 - R_j \times 3 = 0 \Rightarrow R_j = 40 \text{ kN } (\uparrow)$$

$$\sum F_y = 0 \Rightarrow R_{ay} - 120 + R_j = 0$$

$$R_{ay} - 120 + 40 = 0 \Rightarrow R_{ay} = 80 \text{ kN } (\uparrow)$$

$$\sum F_x = 0 \Rightarrow 30 - R_{ax} = 0 \Rightarrow R_{ax} = 30 \text{ kN } (\leftarrow)$$

Joint a

$$\sum F_x = 0 \Rightarrow F_{ac} - 30 = 0 \Rightarrow F_{ac} = 30 \text{ kN } (T)$$

$$\sum F_y = 0 \Rightarrow F_{ab} + 80 = 0 \Rightarrow F_{ab} = -80 \text{ kN } (C)$$

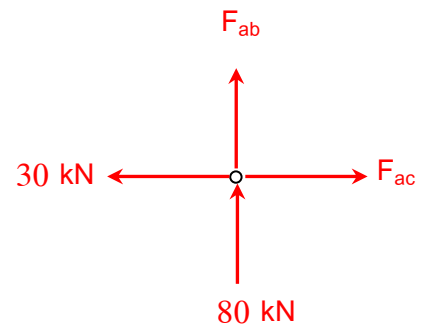

Joint b

$$\sum F_y = 0 \Rightarrow -F_{bc} \left(\frac{4}{5}\right) + 80 = 0 \Rightarrow F_{bc} = 100 \text{ kN (T)}$$

$$\sum F_x = 0 \Rightarrow F_{bc} \left(\frac{3}{5}\right) + F_{bd} + 30 = 0$$

$$100 \times \left(\frac{3}{5}\right) + F_{bd} + 30 = 0 \Rightarrow F_{bd} = -90 \text{ kN (C)}$$

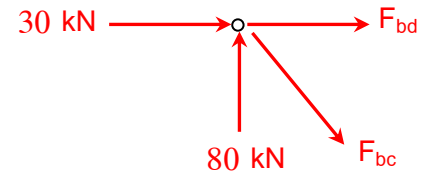

Joint c

$$\sum F_y = 0 \Rightarrow F_{dc} + 100 \left(\frac{4}{5}\right) - 120 = 0 \Rightarrow F_{dc} = 40 \text{ kN (T)}$$

$$\sum F_x = 0 \Rightarrow F_{ce} - 30 - 100 \left(\frac{3}{5}\right) = 0 \Rightarrow F_{ce} = 90 \text{ kN (T)}$$

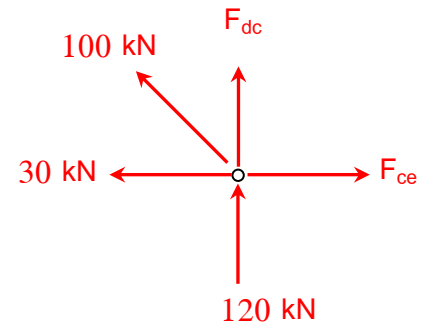

Joint d

$$\sum F_y = 0 \Rightarrow 40 + F_{de} \left(\frac{4}{5}\right) = 0 \Rightarrow F_{de} = -50 \text{ kN (C)}$$

$$\sum F_x = 0 \Rightarrow 90 + F_{df} + F_{de} \left(\frac{3}{5}\right) = 0$$

$$90 + F_{df} - 50 \left(\frac{3}{5}\right) = 0 \Rightarrow F_{df} = -60 \text{ kN (C)}$$

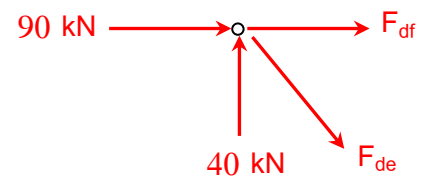

All the member forces are shown in the figure below;

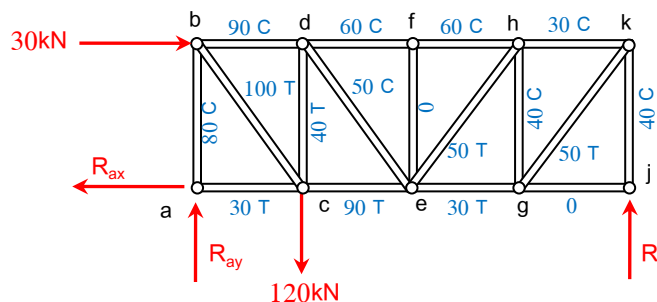

The method of Sections

If the forces in only a few members of a truss are to be found, the method of sections generally provides the most direct means of obtaining these forces. The "*method of sections*" consists of passing an "*imaginary section*" through the truss, thus cutting it into two parts. Provided the entire truss is in equilibrium, each of the two parts must also be in equilibrium; and as a result, the three equations of equilibrium may be applied to either one of these two parts to determine the member forces at the "*cut section*".

Example (2): Calculate the member forces, F_{df} , F_{de} , and F_{ce} for the truss of the previous example using the method of sections.

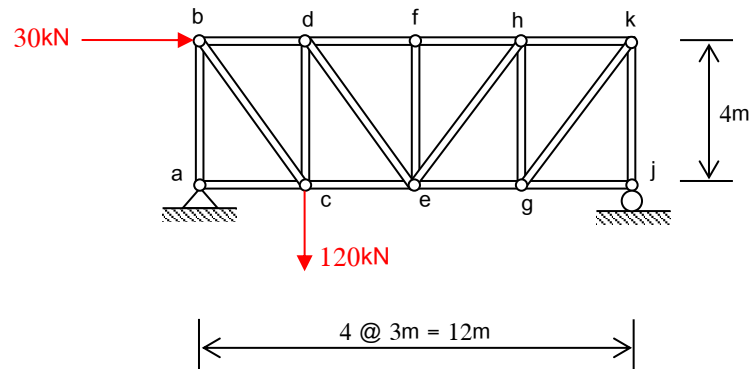

Solution

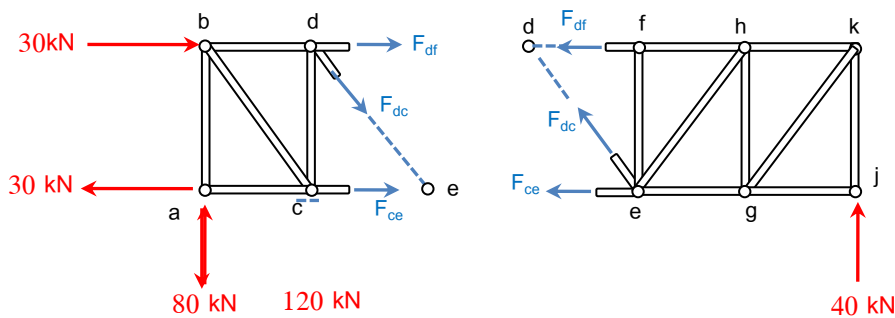

From the right-hand free-body diagram (it has the fewest forces to consider);

$$\sum M_e = 0 \Rightarrow F_{df} \times 4 + 40 \times 6 = 0 \Rightarrow F_{df} = -60 \text{ kN (C)}$$

$$\sum M_d = 0 \Rightarrow F_{ce} \times 4 - 40 \times 9 = 0 \Rightarrow F_{ce} = 90 \text{ kN (T)}$$

$$\sum F_y = 0 \Rightarrow F_{dc} \left(\frac{4}{5}\right) + 40 = 0 \Rightarrow F_{dc} = -50 \text{ kN (C)}$$

Chapter Four

Approximate Analysis of Statically Indeterminate Structures

Approximate methods of analysis are methods by which statically indeterminate structures are reduced into determinate structures, through the use of certain assumption. The determinate structure is then solved by equations of statics.

A- Trusses

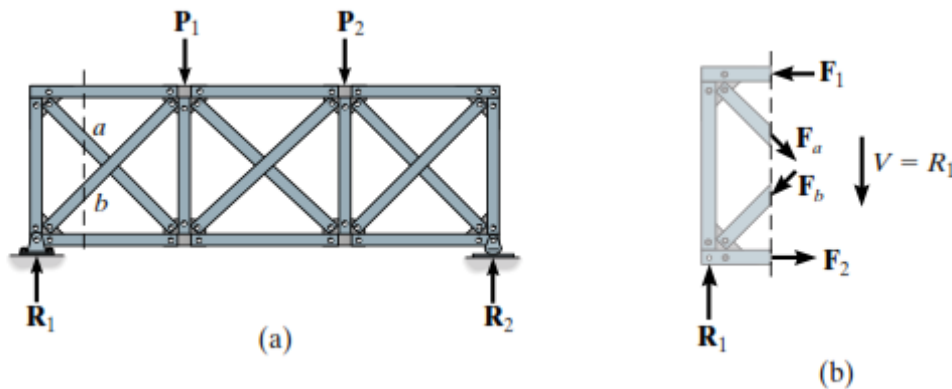

Consider the above truss which has two diagonals in each panel. The truss is statically indeterminate to the third degree. It can be noticed that if a diagonal is removed from each of the three panels, it will render the truss statically determinate

$$b = 16, r = 3, \text{ and } j = 8; \text{ hence}$$

$$b + r > 2j \quad ; \quad 16 + 3 > 16$$

Therefore, we must make three assumptions regarding the bar forces in order to reduce the truss to one that is statically determinate. These assumptions can be made with regard to the cross-diagonals, realizing that when one diagonal in a panel is in tension the corresponding cross-diagonal will be in compression.

Two methods of analysis are generally acceptable;

Method (1): If the diagonals are intentionally designed to be long and slender, it is reasonable to assume that they cannot support a compressive force; otherwise, they may easily buckle. Hence the panel shear is resisted entirely by the tension diagonal, whereas the compressive diagonal is assumed to be *a zero-force member*.

Method (2): If the diagonal members are intended to be constructed from large rolled sections such as angles or channels, they may be equally capable of supporting a tensile and compressive force. Here we will assume that the tension and compression diagonals each carry *half the panel's shear*.

Example: Determine approximately the forces in the members of the truss shown in figure. (i) If the diagonals are constructed from large rolled sections to support both tensile and compressive forces. (ii) If the diagonals can not support compressive force.

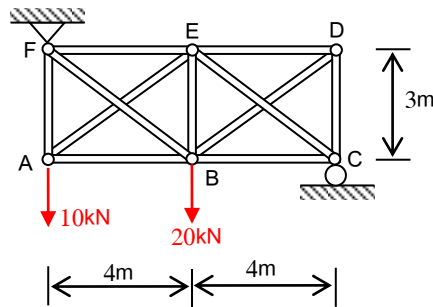

Solution:

Since $b = 11$, $r = 3$, and $j = 6$

So, the truss is statically indeterminate to the second degree.

i) From the whole truss, using the Eqs. of equilibrium

$$\sum M_F = 0 \Rightarrow R_C = 10\text{kN}$$

$$\sum F_Y = 0 \Rightarrow R_{Fy} = 20\text{kN}$$

$$\sum F_X = 0 \Rightarrow R_{Fx} = 0$$

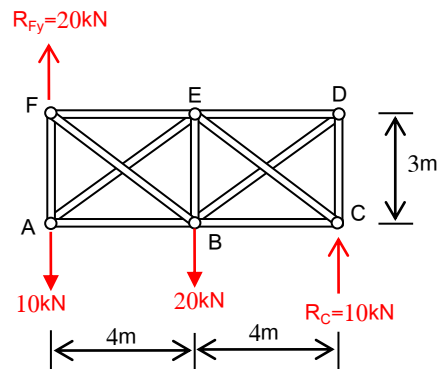

The two assumptions require the tensile and compression diagonals to carry equal forces, i.e. $F_{FB} = F_{AE} = F$. For a vertical section through the left panel

$$\sum F_Y = 0 \Rightarrow 20 - 10 - 2F \left(\frac{3}{5}\right) = 0$$

$$F = 8.33\text{kN} \text{ , hence } F_{AE} = 8.33 \text{ kN (C) and } F_{FB} = 8.33\text{kN (T)}$$

$$\sum M_F = 0 \Rightarrow F_{AB} \times 3 - F_{AE} \left(\frac{4}{5}\right) \times 3 = 0$$

$$F_{AB} \times 3 - 8.33 \times \left(\frac{4}{5}\right) \times 3 = 0 \text{ ; } F_{AB} = 6.67 \text{ kN (T)}$$

$$\sum M_A = 0 \Rightarrow F_{FE} \times 3 + F_{FB} \left(\frac{4}{5}\right) \times 3 = 0$$

$$F_{FE} \times 3 + 8.33 \times \left(\frac{4}{5}\right) \times 3 = 0 \text{ ; } F_{FE} = - 6.67 \text{ kN (C)}$$

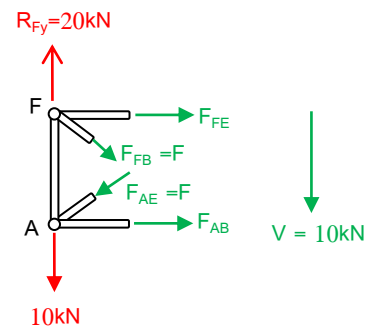

Assume a vertical section through the right panel

$$\sum F_Y = 0 \Rightarrow 10 - 2F \left(\frac{3}{5}\right) = 0 ; F = 8.33\text{kN} ,$$

hence $F_{BD} = 8.33 \text{ kN (T)}$ and $F_{EC} = 8.33\text{kN (C)}$

$$\sum M_D = 0 \Rightarrow F_{BC} \times 3 - F_{EC} \left(\frac{4}{5}\right) \times 3 = 0$$

$$F_{BC} \times 3 - 8.33 \times \left(\frac{4}{5}\right) \times 3 = 0 ; F_{BC} = 6.67 \text{ kN (T)}$$

$$\sum M_C = 0 \Rightarrow F_{ED} \times 3 + F_{BD} \left(\frac{4}{5}\right) \times 3 = 0$$

$$F_{ED} \times 3 + 8.33 \times \left(\frac{4}{5}\right) \times 3 = 0 ; F_{ED} = - 6.67 \text{ kN (C)}$$

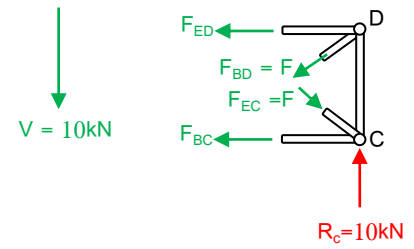

Using F.B.D. of joints D, E, and F ;

$$\sum F_Y = 0 \Rightarrow F_{DC} + 8.33 \times \left(\frac{3}{5}\right) = 0 ; F_{DC} = -5 \text{ kN (C)}$$

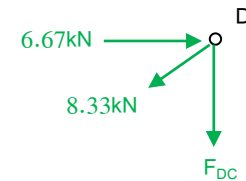

$$\sum F_Y = 0 \Rightarrow F_{EB} - 2 \times 8.33 \left(\frac{3}{5}\right) = 0 ; F_{EB} = 10 \text{ kN (T)}$$

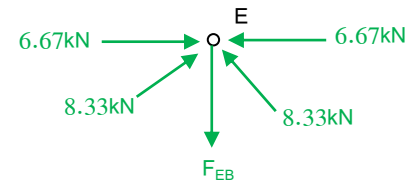

$$\sum F_Y = 0 \Rightarrow 20 - F_{AF} - 8.33 \left(\frac{3}{5}\right) = 0 ; F_{AF} = 15 \text{ kN (T)}$$

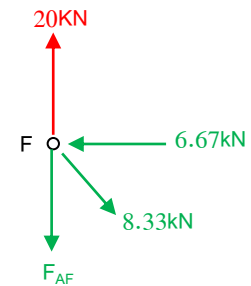

ii) If the diagonals cannot support a compressive force ;

Assume a vertical section through the left panel

$$F_{AE} = 0$$

$$\sum F_Y = 0 \Rightarrow 20 - 10 - F_{FB} \left(\frac{3}{5}\right) = 0$$

$$F_{FB} = 16.67\text{kN (T)}$$

$$\sum M_F = 0 \Rightarrow F_{AB} \times 3 = 0 ; F_{AB} = 0$$

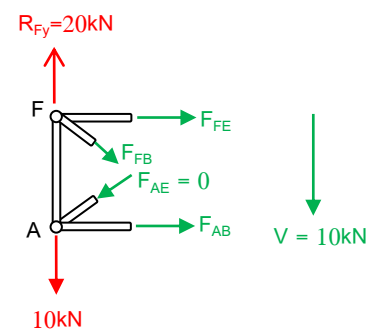

$$\sum M_A = 0 \Rightarrow F_{FE} \times 3 + F_{FB} \left(\frac{4}{5}\right) \times 3 = 0$$

$$F_{FE} \times 3 + 16.67 \left(\frac{4}{5}\right) \times 3 = 0 ; F_{FE} = -13.33 \text{ kN (C)}$$

Assume a vertical section through the right panel

$$F_{EC} = 0$$

$$\sum F_Y = 0 \Rightarrow 10 - F_{BD} \left(\frac{3}{5}\right) = 0 ; F_{BD} = 16.67 \text{ kN (T)}$$

$$\sum M_D = 0 \Rightarrow F_{BC} \times 3 = 0 ; F_{BC} = 0$$

$$\sum F_X = 0 \Rightarrow F_{ED} + F_{BD} \left(\frac{4}{5}\right) = 0$$

$$F_{ED} + 16.67 \times \left(\frac{4}{5}\right) = 0 ; F_{ED} = -13.33 \text{ kN (C)}$$

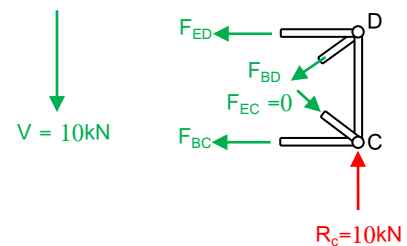

Using F.B.D. of joints D, E, and F ;

$$\sum F_Y = 0 \Rightarrow F_{DC} + 16.67 \times \left(\frac{3}{5}\right) = 0 ; F_{DC} = -10 \text{ kN (C)}$$

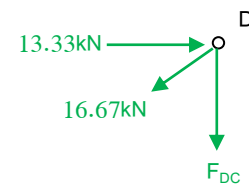

$$\sum F_Y = 0 \Rightarrow F_{EB} = 0$$

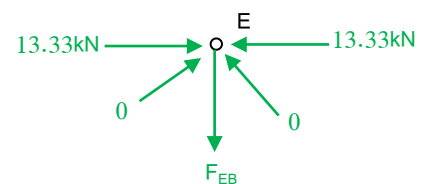

$$\sum F_Y = 0 \Rightarrow 20 - F_{AF} - 16.67 \left(\frac{3}{5}\right) = 0 ; F_{AF} = 10 \text{ kN (T)}$$

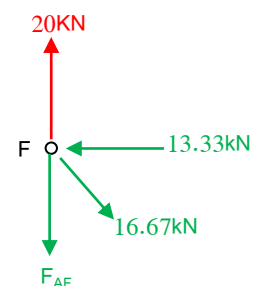

B- Vertical Loads on Building Frames

Consider a typical girder located within a building, Fig. (1), bent and subjected to a uniform vertical load, as shown in Fig. (2). The column supports at A and B will each exert three reactions on the girder, and therefore the girder will be statically indeterminate to the third degree (6 reactions – 3 equations of equilibrium). To make the girder statically determinate, an approximate analysis will therefore require three assumptions. If the columns are extremely stiff, no rotation at A and B will occur, and the deflection curve for the girder will look like that shown in Fig. (3). For this case, the inflection points (Points of zero moments) occur at $0.21L$ from each support.

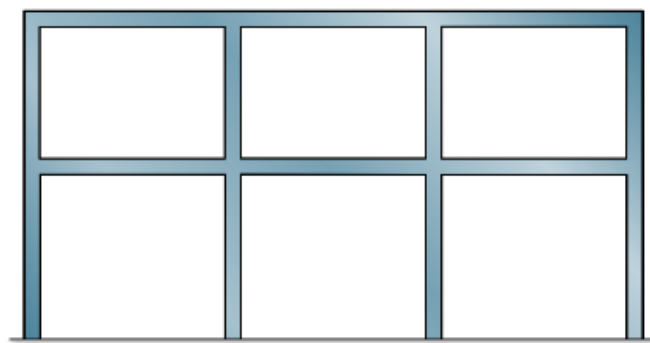

Fig. (1)

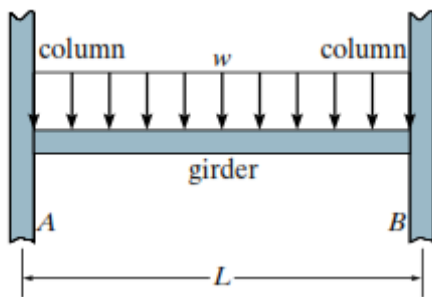

Fig. (2)

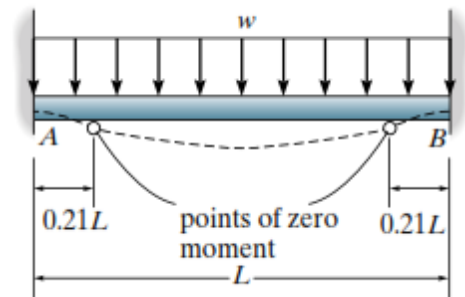

Fig. (3)

If, however, the column connections at A and B are very flexible, then like a simply supported beam, zero moment will occur at the supports, Fig. (4).

In reality, however, the columns will provide some flexibility at the supports, and therefore we will assume that zero moment occurs at the "average point" between the two extremes, $(0.21L + 0)/2 \cong 0.1L$ from each support, Fig. (5).

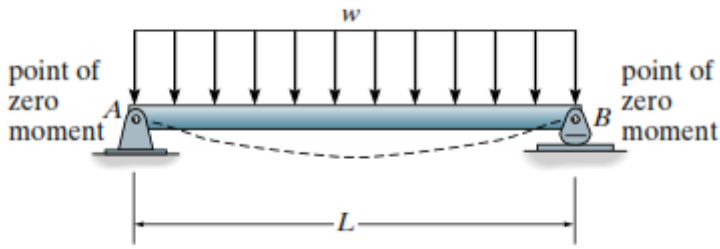

Fig. (4)

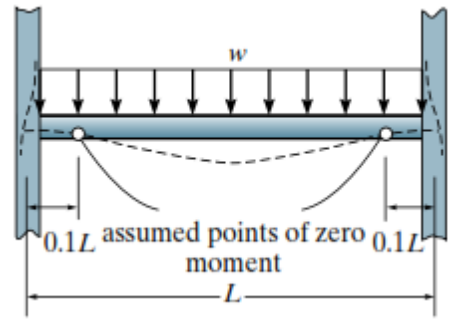

Fig. (5)

In summary then, each girder of length " L " may be modeled by a simply supported span of length $0.8L$ resting on two cantilevered ends, each having a length of $(0.1L)$, Fig. (6). The following three assumptions are incorporated in this model;

- 1- There is zero moment in the girder, $0.1L$ from the left support.
- 2- There is zero moment in the girder, $0.1L$ from the right support.
- 3- The girder does not support an axial force.

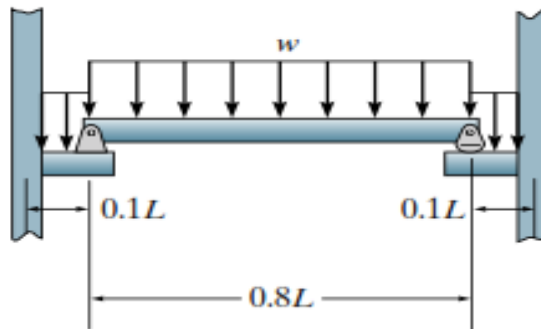
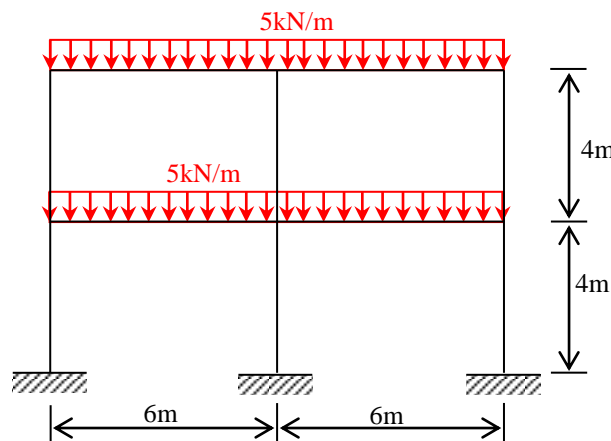

Fig. (6)

Example: Determine (approximately) the shear force and bending moments for the girders of the building frame shown in figure below.



Solution:

As the span lengths and loads for the four girders are the same, the approximate shear and bending moment diagrams for the girders will also be the same.

The inflection points are assumed to occur in the beam at ($0.1L = 0.6\text{m}$), the middle portion of the girder, which has a length of ($0.8L = 4.8\text{m}$), is simply supported on the two end portions, each of length 0.6m .

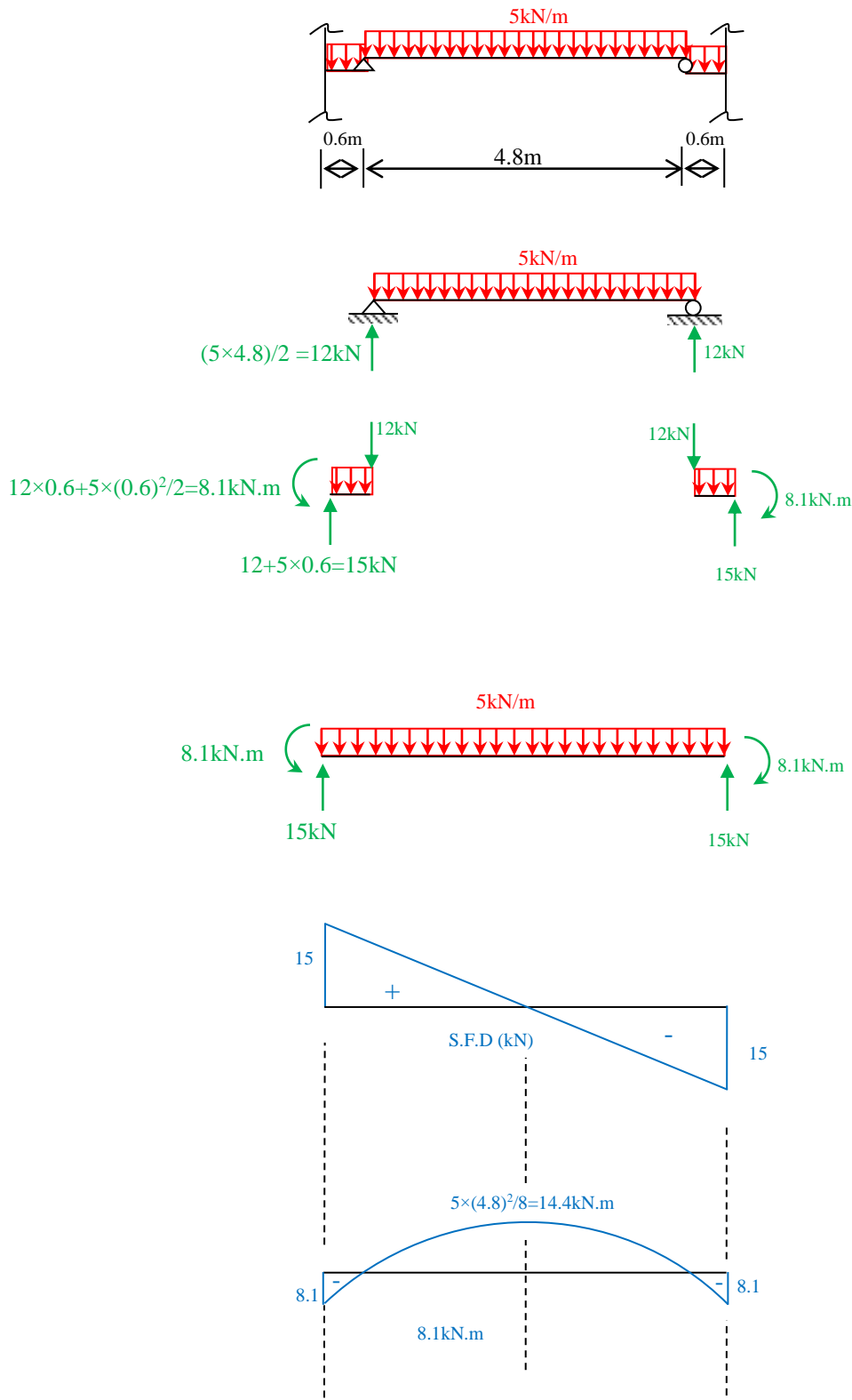

Theory of Structures

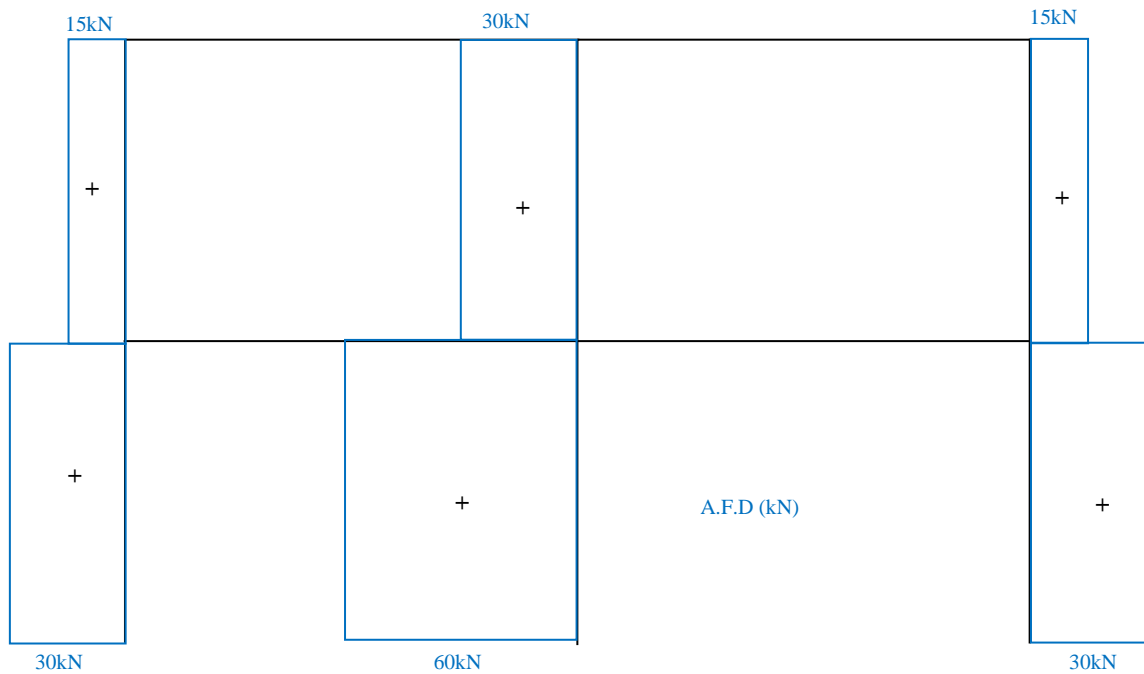
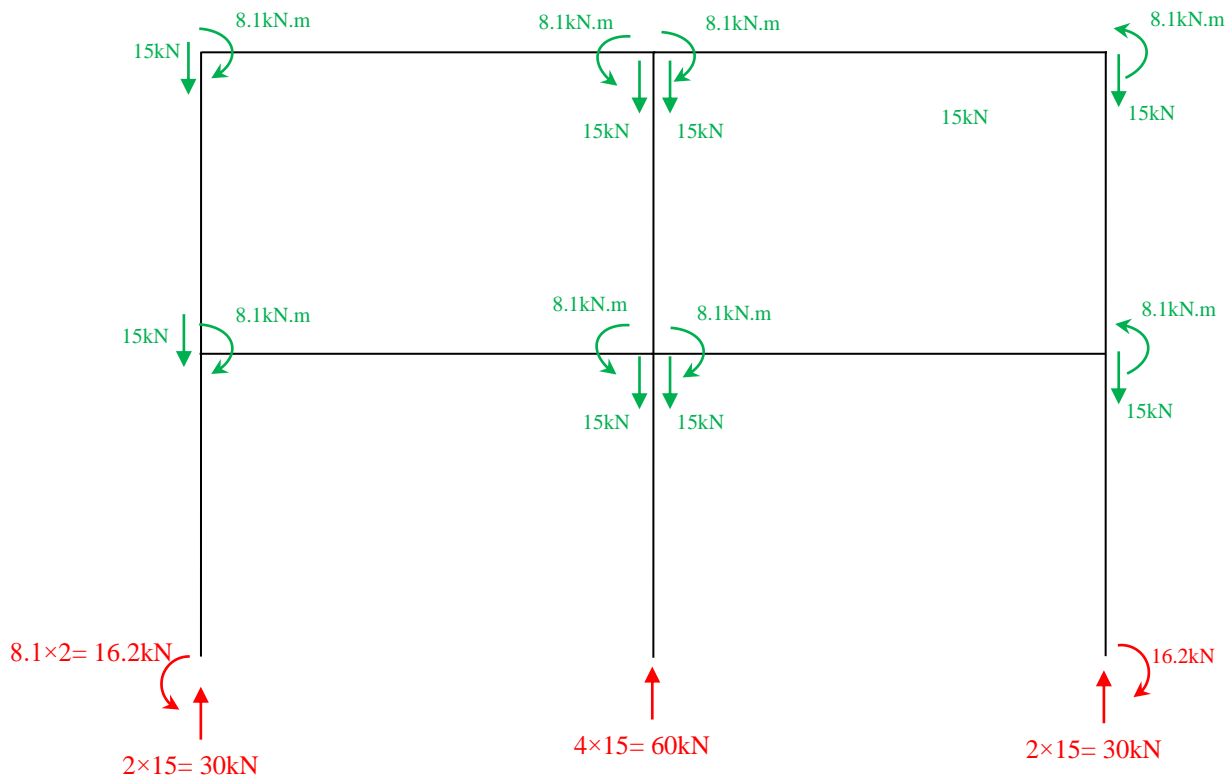

Theory of Structures

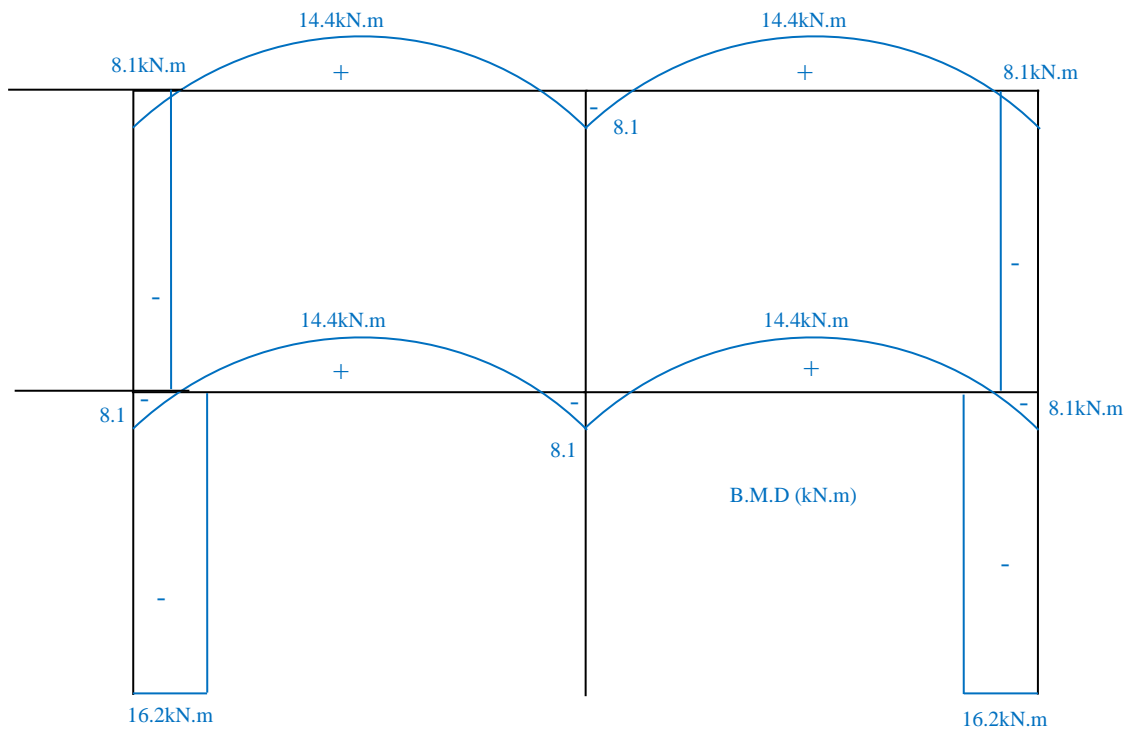
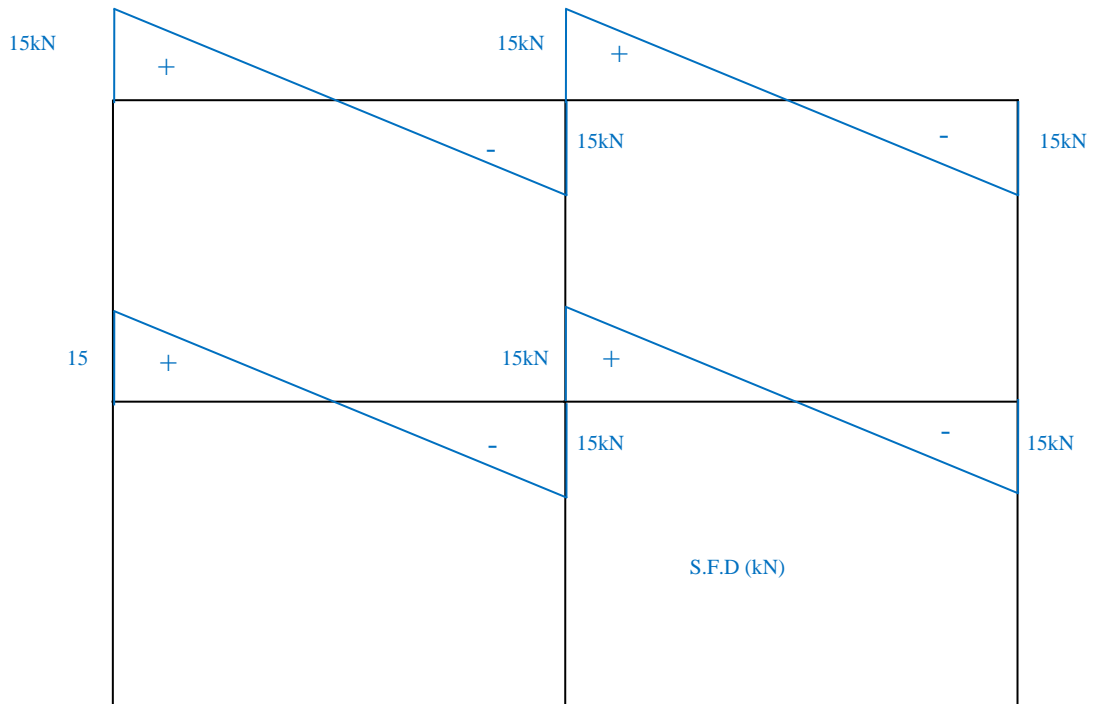

C- Lateral Loads on Building Frames

Portal Method:

The behavior of rectangular building frame is different under lateral (horizontal) loads than under vertical loads, so different assumptions must be used.

A method commonly used for the approximate analysis of relatively low building frames is the "Portal Method".

A building frame deforms as shown in figure below,

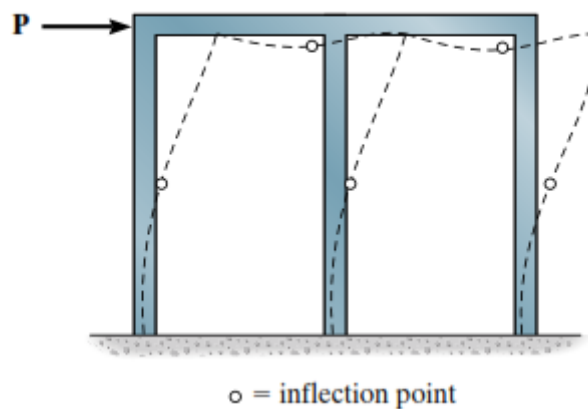

Therefore, it is appropriate to assume inflection points occur at the center of the columns and girders.

If we consider the frame to be composed of a series of portal, then as a further assumption, the interior columns would represent the effect of two portal columns and would therefore carry twice the shear (V) as the two exterior columns.

In summary, the portal method requires the following assumptions;

- 1- A hinge is placed at the center of each girder, since this is assumed to be a point of zero moment.
- 2- A hinge is placed at the center of each column, since this is assumed to be a point of zero moment.
- 3- At a given floor level, the shear at the interior columns is twice that at the exterior columns.

Example: Use the portal method to determine the external reactions, and draw the axial load, shear force, and bending moment diagrams for the frame shown in figure.

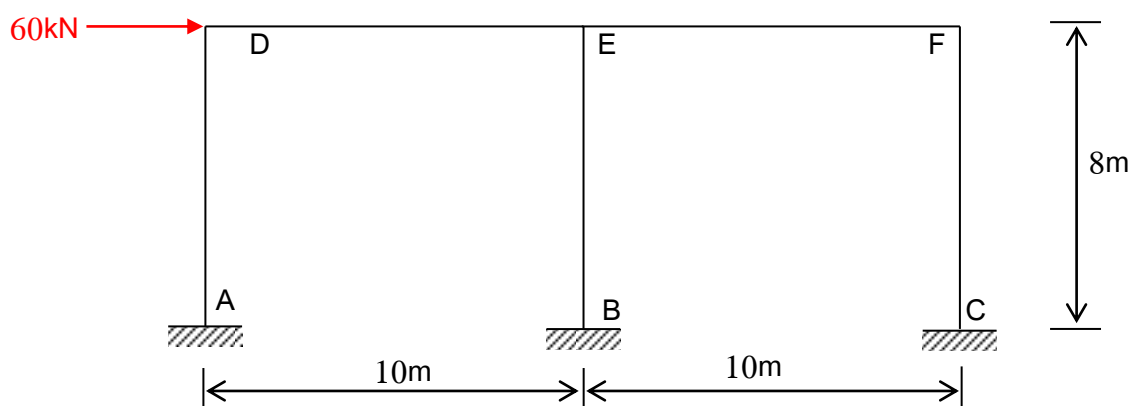

Solution:

- i- Simplified frame: The simplified frame for approximate analysis is obtained by inserting internal hinges at the midpoints of all members of the given frame.
- ii- Column shears: The shear in the interior column BE is assumed to be twice as much as in the exterior columns AD and CF.

By separating the frame into two parts at the midpoint of the columns (upper and lower) where the hinges were assumed. From shear forces of the upper part

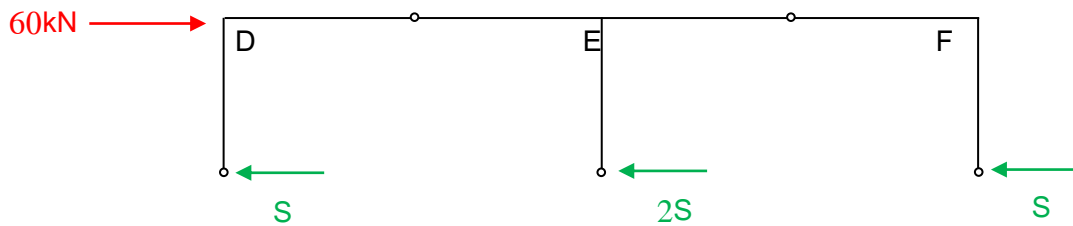

$$\sum F_x = 0 \Rightarrow 60 - S - 2S - S = 0 \Rightarrow S = 15\text{kN}$$

Thus the shear forces (Horizontal reactions) at the lower ends of the columns are;

$$H_A = H_C = S = 15\text{kN} (\leftarrow)$$

$$H_B = 30\text{kN} (\leftarrow)$$

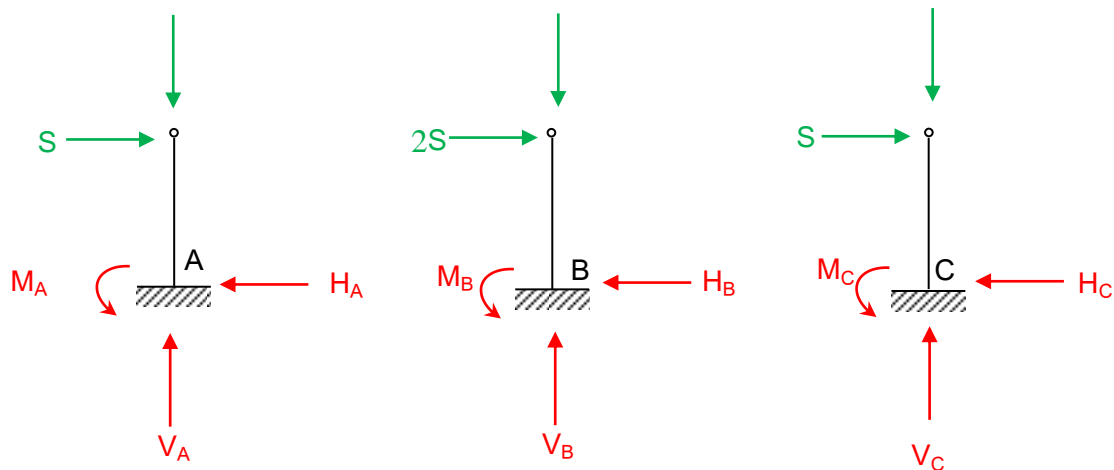

Shear forces at the upper ends of the columns are obtained by applying $\sum F_x = 0$ to the free body of each column,

$$H_D = H_F = 15\text{kN} (\rightarrow)$$

$$H_E = 30\text{kN} (\rightarrow)$$

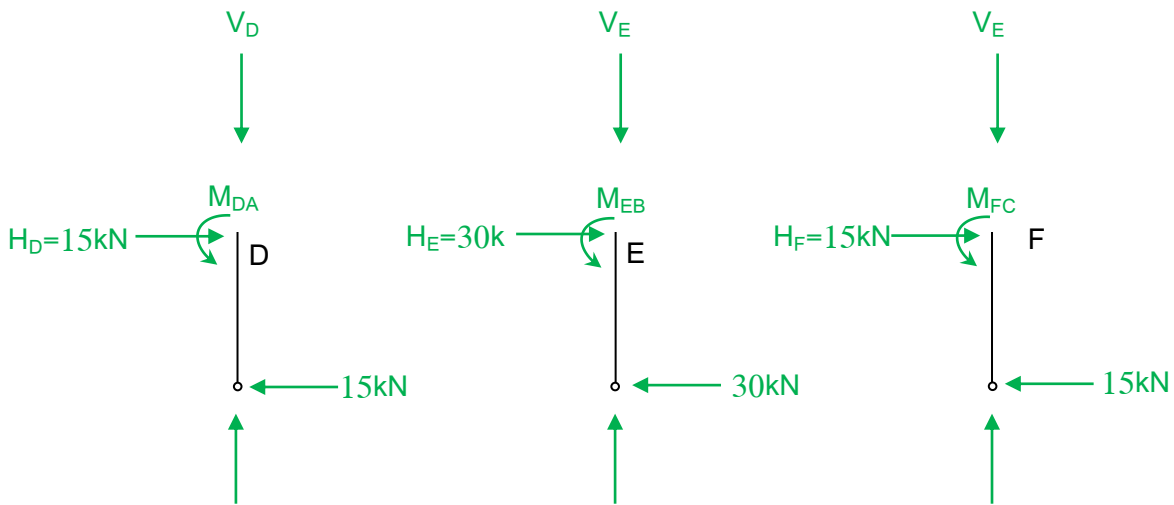

iii- Column moments: The column end moment moments can be computed using Eq. of $\sum M=0$ about lower and upper end of the columns,

$$M_{AD} = M_{CF} = M_{DA} = M_{EC} = 15 \times 4 = 60 \text{ kN.m (} \curvearrowleft \text{)}$$

$$M_{BE} = M_{EB} = 30 \times 4 = 120 \text{ kN.m (} \curvearrowleft \text{)}$$

iv- Girder axial forces, moments, and shear:

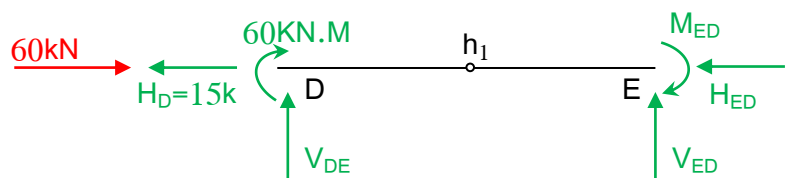

For Girder DE,

$$\text{Using equation of } \sum F_x = 0 \Rightarrow 60 - H_{ED} - 15 = 0 \Rightarrow H_{ED} = 45 \text{ kN (} \leftarrow \text{)}$$

$$\sum M_{h1} = 0 \text{ (for left part)} \Rightarrow V_{DE} \times 5 + 60 = 0 \Rightarrow V_{DE} = -12 \text{ kN.m (} \downarrow \text{)} = V_D$$

$$\sum F_y = 0 \Rightarrow -12 + V_{ED} = 0 \Rightarrow V_{ED} = 12 \text{ kN (} \uparrow \text{)}$$

$$\sum M_{h1} = 0 \text{ (for right part)} \Rightarrow 12 \times 5 - M_{ED} = 0 \Rightarrow M_{ED} = 60 \text{ kN.m (} \curvearrowleft \text{)}$$

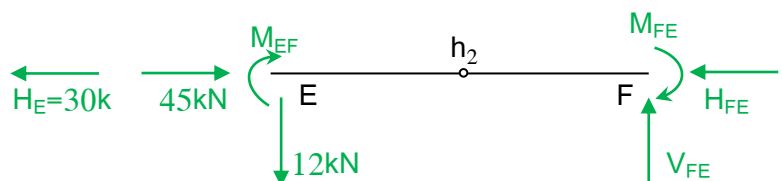

For Girder EF,

$$\text{Using equation of } \sum F_x = 0 \Rightarrow 45 - H_{FE} - 30 = 0 \Rightarrow H_{FE} = 15 \text{ kN (} \leftarrow \text{)} = H_F$$

Theory of Structures

$$\sum F_Y = 0 \Rightarrow -12 + V_{FE} = 0 \Rightarrow V_{FE} = 12 \text{ kN } (\uparrow) = V_F$$

$$\sum M_{h2} = 0 \text{ (for left part)} \Rightarrow -12 \times 5 + M_{EF} = 0 \Rightarrow M_{EF} = 60 \text{ kN.m } (\curvearrowright)$$

$$\sum M_{h2} = 0 \text{ (for right part)} \Rightarrow 12 \times 5 - M_{FE} = 0 \Rightarrow M_{FE} = 60 \text{ kN.m } (\curvearrowright)$$

v- Column axis:

Using $\sum F_Y = 0$

$$V_A - 12 = 0$$

$$V_A = 12 \text{ kN}$$

and, $V_c = 12 \text{ kN}$

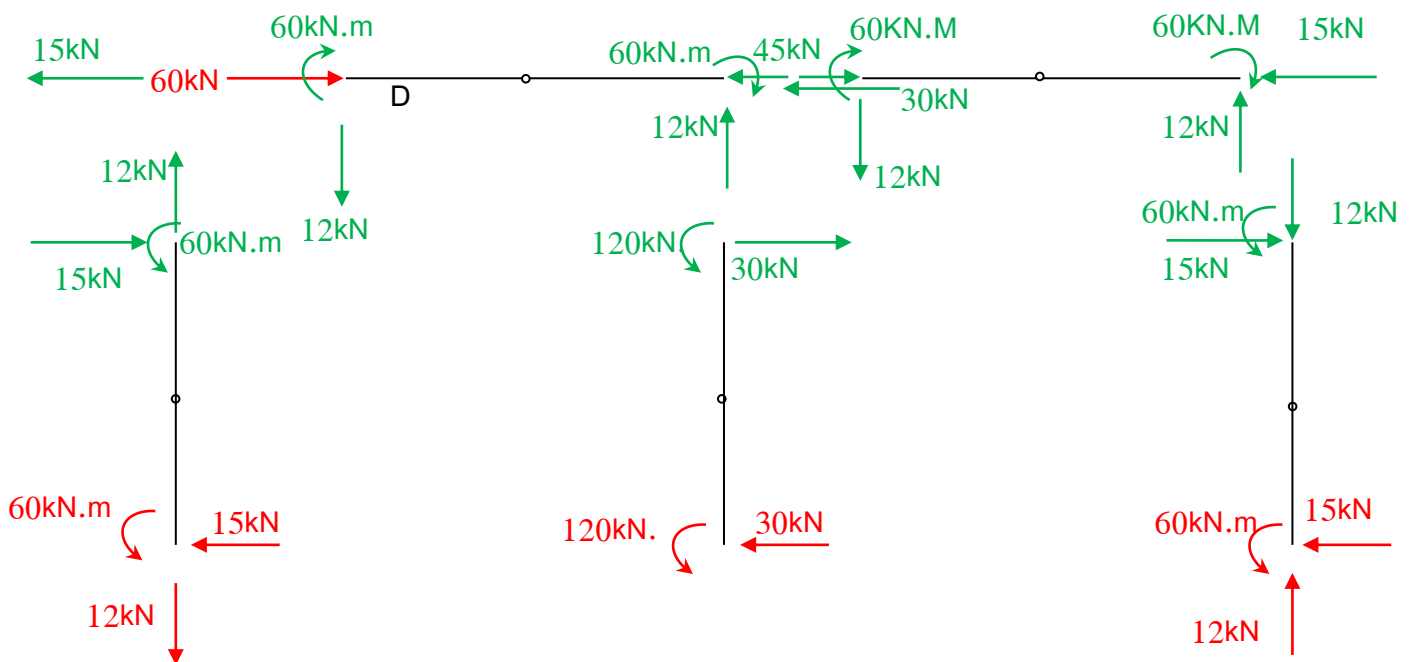
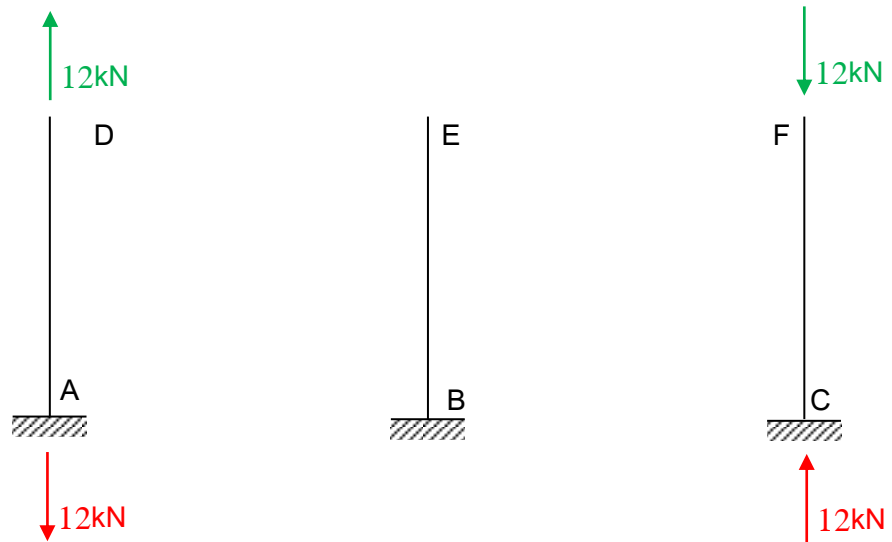

Theory of Structures

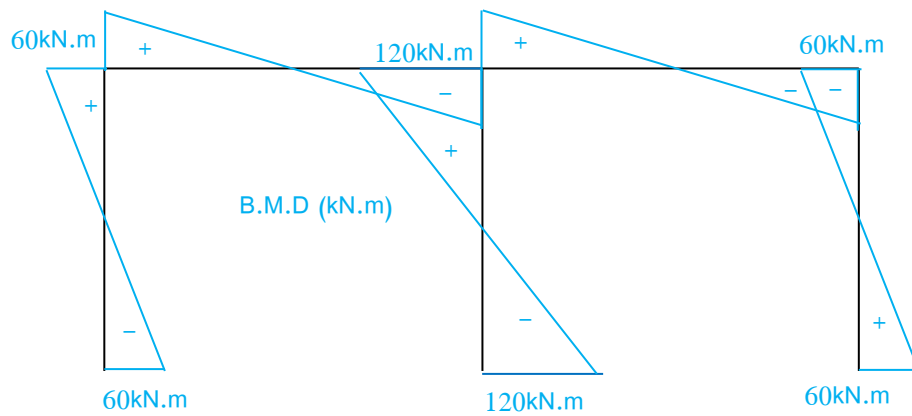
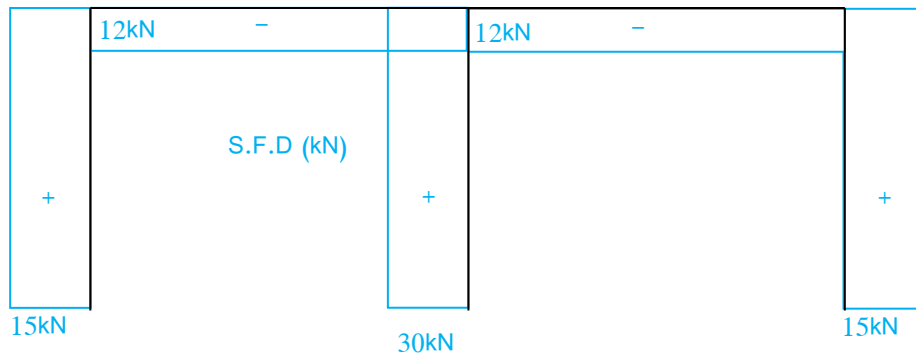
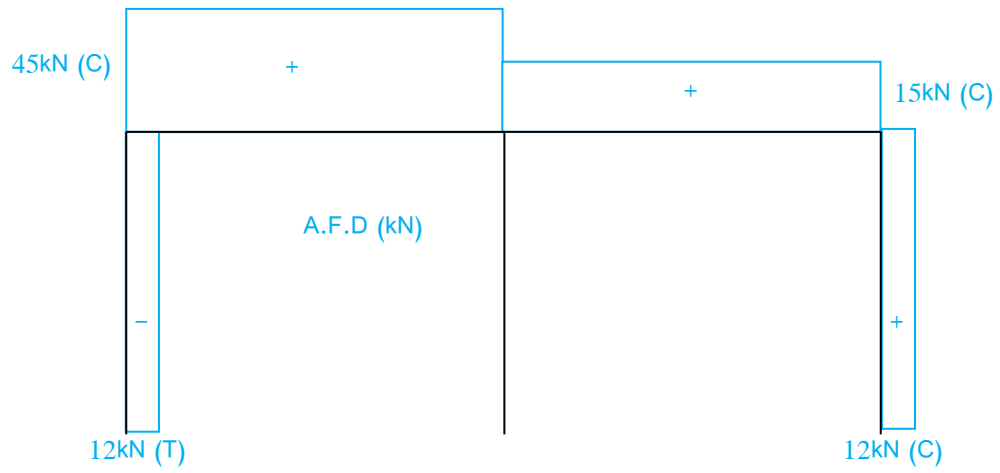

Chapter Five

Influence Lines for Statically Determinate Structures

An "influence line" is a diagram showing the change in the values of a particular function (reaction, member axial force, internal shear, or bending moment) as a unit concentrated load moves across the structure.

Influence lines play an important role in the design of bridges, industrial crane, conveyors, and other structures where loads move across their span.

An influence line is constructed by placing a unit load at a 'variable position x ' on the member and then computing the value of reactions, shear force, or bending moment at the point as a function of x .

In this manner, the equations of the various line segments composing the influence line can be determined and plotted.

Consider the simply supported beam shown in figure.

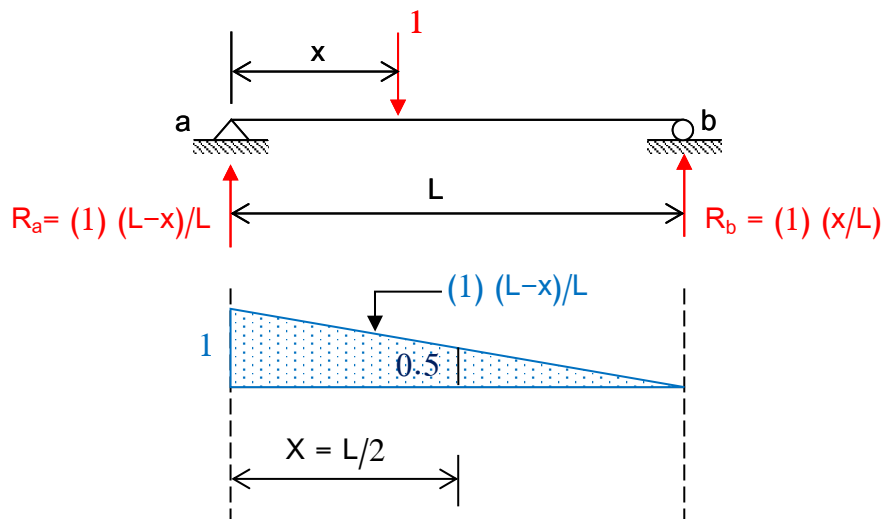

If the influence line for the reaction at point " a "is required, a single concentrated load is moved across the span from point " a " to " b ", and the reaction at point " a " is calculated. Placing the unit load at a typical position located at distance " x " from point " a " and summing moments about point " b " gives;

$$\sum Mb = R_a(L) - (1)(L-x) = 0$$

$$R_a = \frac{(L-x)}{L} \cdot (1) \quad \text{"Straight line"}$$

When the load is positioned at the left reaction ($x = 0$), the value of R_a is a unity. As the load moves across the span and reaches mid-span ($x = L/2$), the diagram shows that R_a equals 0.5 . When the unit load is at the right support ($x = L$) R_a equals zero.

Influence Lines for Beams

For beams, we are interested in the influence lines for the reactions, as well as the change in the internal quantities in the beams as the loading moves across the structure. Therefore, influence lines for the shear and moment at a specific cross-section must also be constructed for beam structures.

In order to do so, it is necessary to make an imaginary cut through the beam at the point of interest and then compute the value of the shear and moment at this cross-section as the unit concentrated load traverses the beam.

For the simply supported beam discussed in the previous section, the influence line for the reaction at point " b " can also be obtained by placing the unit load at a typical point on the beam and summing moments about point " a ", giving

$$\sum M_a = R_b \cdot (L) - (1)(x) = 0$$

$$R_b = \frac{x}{L} \cdot (1) \quad \text{"Straight line"}$$

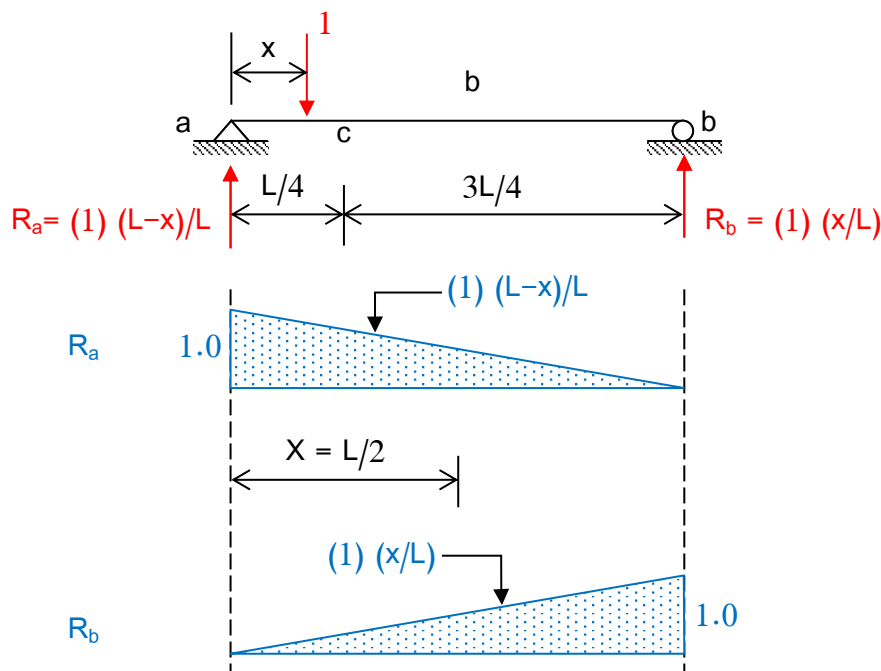

It is of interest to note that the sum of the influence ordinates for R_a and R_b is (1) for a given " x " value of their respective influences lines. Summation of forces in the vertical direction $R_a + R_b - 1 = 0$

$$\text{Hence, } R_a + R_b = 1$$

To obtain the influence line for shear and moment at point " c " as the unit load moves across the beam, the free-body diagrams are drawn for $0 \leq x < L/4$ and $L/4 < x \leq L$.

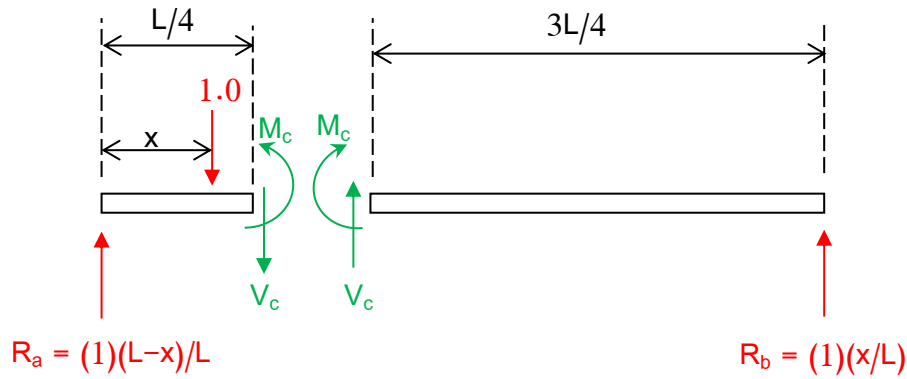

Fig. (1)
 $0 \leq x < L/4$

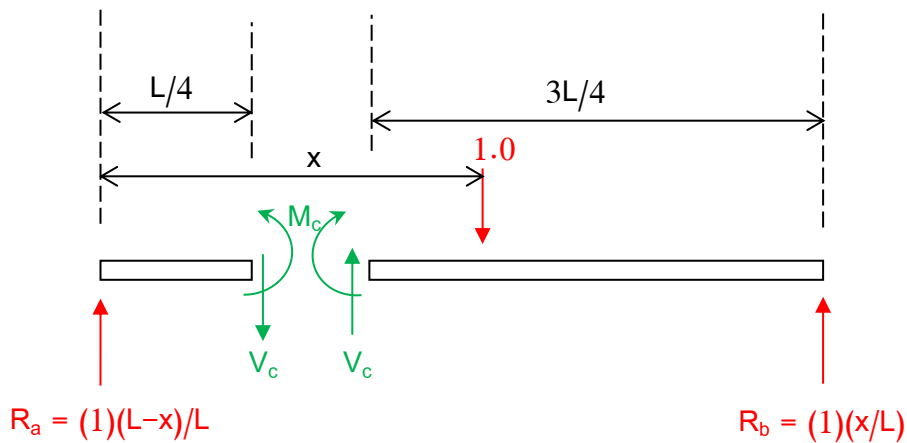

Fig. (2)
 $L/4 < x \leq L$

Figure (1) is correct if the unit load is located between points " a " and " c ", and Fig. (2) is valid for the load situated between points " c " and " b ".

From the left part of Fig. (1), the expression for shear force is given as;

$$V_c = -1 + R_a = -1 + \frac{(L-x)}{L} = -\frac{x}{L} \quad 0 \leq x < L/4 \quad \text{----- (5-1)}$$

Alternatively, the right hand part

$$V_c = -R_b = -\frac{x}{L} \quad 0 \leq x < L/4 \quad \text{----- (5-2)}$$

Theory of Structures

Either of the above equations can be used to construct the influence line for V_c for the segment from " a " to " c "

As the unit load traverses the segment from points " c " to " b ", Fig (2) is used to investigate the shear at section " c " .

Using the left part;

$$V_c = R_a = \frac{L-x}{L} \quad L/4 < x \leq L \quad \text{----- (5-3)}$$

The right-hand part;

$$V_c = 1 - R_b = 1 - \frac{x}{L} = \frac{L-x}{L} \quad L/4 < x \leq L \quad \text{----- (5-4)}$$

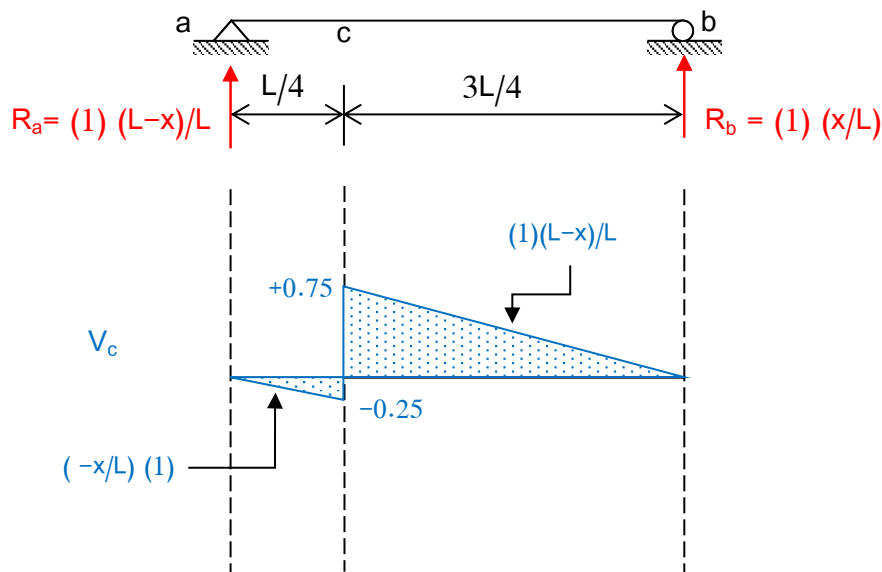

To obtain the moment influence line for the beam it is necessary to write expression for the moment at point " c " as the unit concentrated load is positioned at all locations on the span.

For the load positioned between points " a " and " c " ;

$$\begin{aligned} M_c &= R_a \left(\frac{L}{4}\right) - (1) \left(\frac{L}{4} - x\right) \\ &= \left(\frac{L-x}{L}\right) \left(\frac{L}{4}\right) - \left(\frac{L}{4} - x\right) = \frac{L}{4} - x \frac{L}{4} - \frac{L}{4} + x = \frac{3x}{4} \quad 0 \leq x \leq \frac{L}{4} \end{aligned}$$

and

Theory of Structures

$$M_c = R_b \left(\frac{3L}{4}\right) = \left(\frac{x}{L}\right) \left(\frac{3L}{4}\right) = \frac{3x}{4} \quad 0 \leq x \leq \frac{L}{4}$$

As the load goes from point " c " to " b " ;

$$M_c = R_a \left(\frac{L}{4}\right) = \left(\frac{L-x}{L}\right) \left(\frac{L}{4}\right) = \frac{L-x}{4} \quad \frac{L}{4} \leq x \leq L$$

and

$$M_c = R_b \left(\frac{3L}{4}\right) - (1) \left(x - \frac{L}{4}\right) = \frac{x}{L} \left(\frac{3L}{4}\right) - (1) \left(x - \frac{L}{4}\right)$$

$$= \frac{3x}{4} - x + \frac{L}{4} = \frac{L-x}{4} \quad \frac{L}{4} \leq x \leq L$$

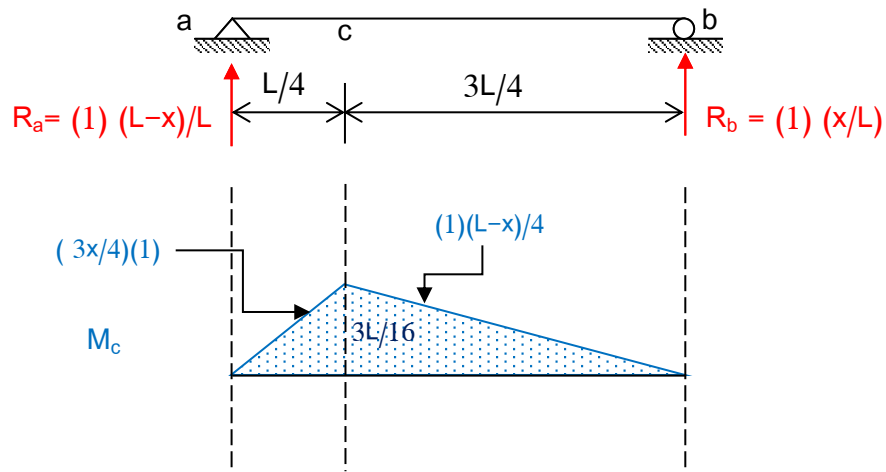

Example (1): Draw the influence lines for R_a , M_a , V_b , and M_b for the cantilever beam.

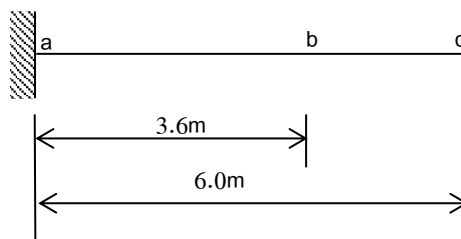

Solution

$$\sum F_y = 0 \Rightarrow R_a = 1$$

$$\sum M_a = 0 \Rightarrow M_a = -1x$$

when the load moves from " a " to " b "

$$V_b = R_a - 1 = 1 - 1 = 0$$

$$M_b = 3.6R_a + M_a - 1(3.6-x) = 3.6 - 1x - 3.6 + x = 0$$

when the load moves from " b " to " c "

$$V_b = R_a = 1$$

$$M_b = 3.6R_a + M_a = 3.6 \times 1 - x = 3.6 - x$$

$$\text{at } x = 3.6 \Rightarrow M_b = 3.6 - 3.6 = 0$$

$$\text{at } x = 6 \Rightarrow M_b = 3.6 - 6 = -2.4$$

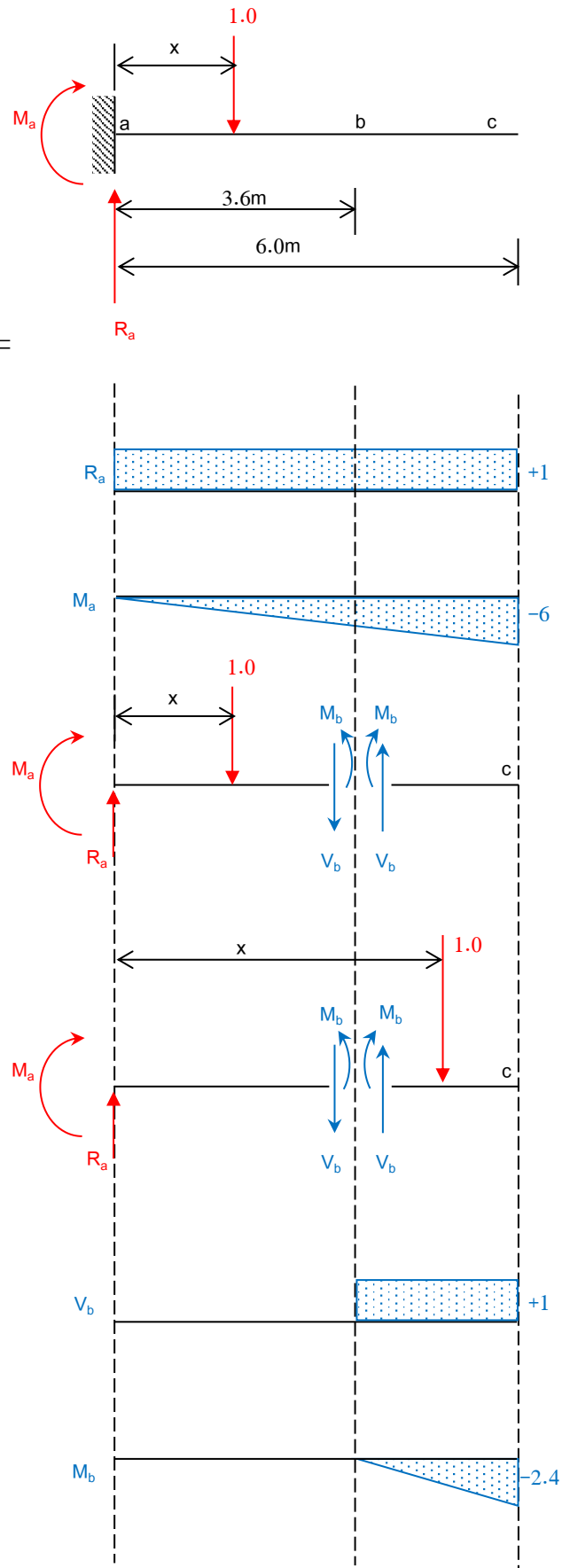

Example (2): Draw the influence lines for R_a , R_c , V_b , M_b , M_c , V_{c-} , V_{c+} (the shear to the left and right of point " c " , respectively)

Solution

$$\sum M_a = 0 \Rightarrow R_c = \frac{x}{10}$$

$$\sum M_c = 0 \Rightarrow R_a = \frac{10-x}{10}$$

From Fig. (1);

For the load between " a " and " b "

$$V_b = R_a - 1 = -R_c = -\frac{x}{10}$$

$$M_b = 6R_a - 1(6 - x) = 4R_c = \frac{4x}{10}$$

For the load between " b " and " d "

$$V_b = R_a - 1 = -R_c = \frac{10-x}{10}$$

$$M_b = 6R_a = 4R_c - (x - 6) = \frac{6(10-x)}{10}$$

From Fig. (2);

For the load between " a " and " c "

$$V_{c-} = R_a - 1 = -R_c = -\frac{x}{10}$$

$$V_{c+} = 0$$

$$M_c = 10R_a - (10 - x) = 10 \times \frac{10-x}{10} - (10 - x) = 0$$

For the load between " c " and " d "

$$V_{c-} = R_a = \frac{10-x}{10}$$

$$V_{c+} = 1$$

$$M_c = 10R_a = 10 \times \frac{10-x}{10} = (10 - x)$$

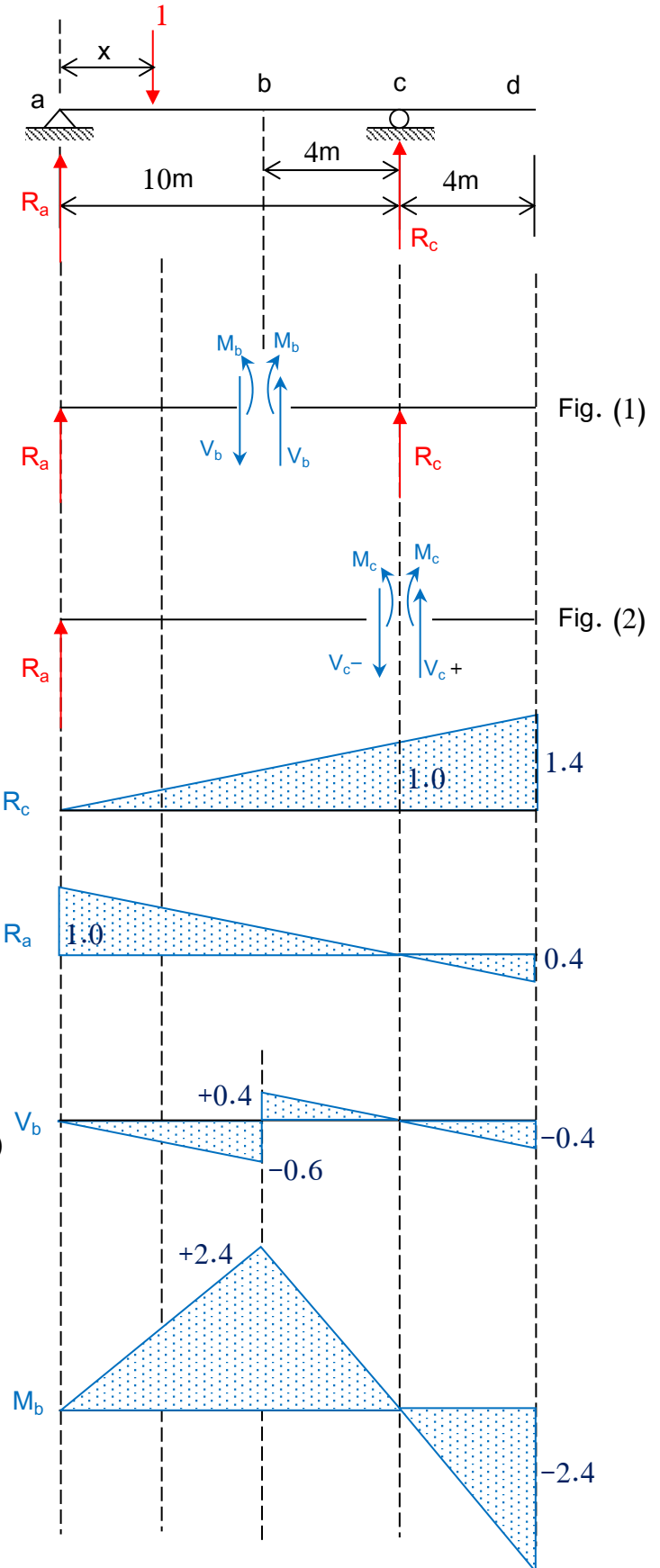

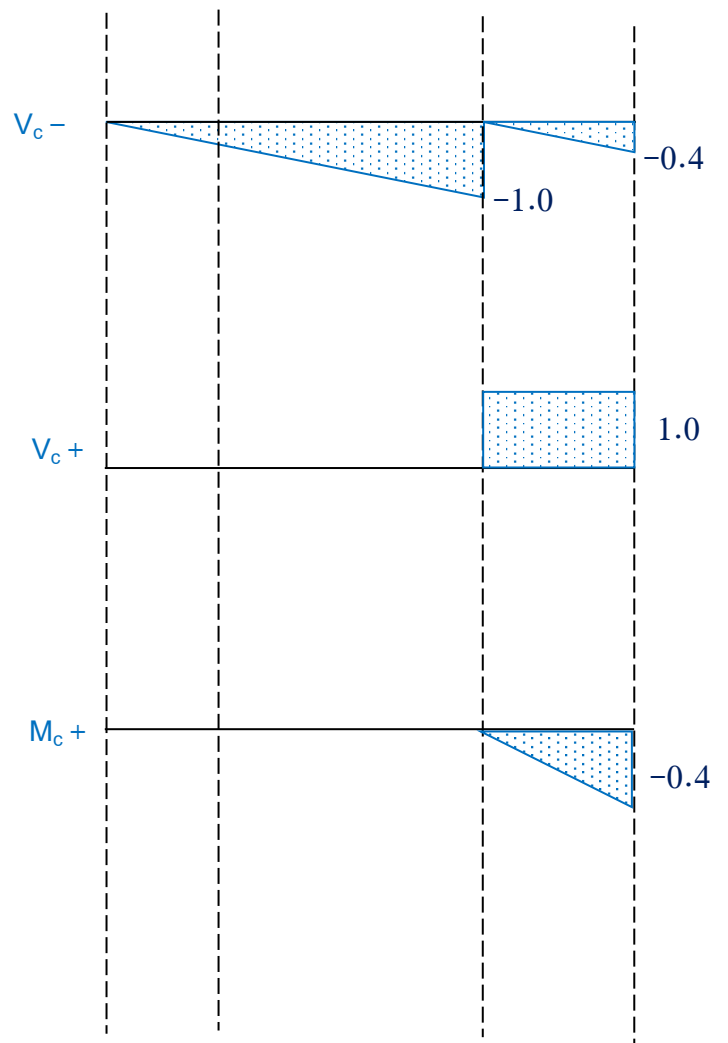

Example (3): Draw the influence lines for R_a , R_d , R_f , V_b , M_b , V_e , M_e for the beam illustrated.

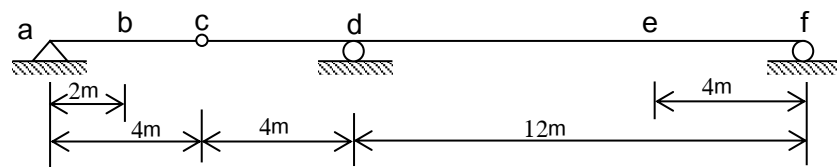

Solution

For the load between " a " and " c ";

$$\sum M_c = 0 \text{ (left part)}$$

$$4R_a - (4-x) = 0 \Rightarrow R_a = \frac{4-x}{4}$$

$$\sum M_f = 0 \text{ (whole beam)}$$

$$20R_a - (20-x) + 12 R_d = 0$$

$$20 \left(\frac{4-x}{4} \right) - (20-x) + 12 R_d = 0$$

$$R_d = \frac{x}{3}$$

$$\sum F_y = 0 \text{ (whole beam)}$$

$$R_a + R_f + R_d - 1 = 0$$

$$\frac{4-x}{4} + R_f + \frac{x}{3} - 1 = 0$$

$$R_f = -\frac{x}{12}$$

For the load between " c " and " f ";

$$\sum M_c = 0 \text{ (left part)}$$

$$R_a = 0$$

$$\sum M_f = 0 \text{ (whole beam)}$$

$$20R_a - (20-x) + 12 R_d = 0$$

$$0 - (20-x) + 12 R_d = 0$$

$$R_d = \frac{20-x}{12}$$

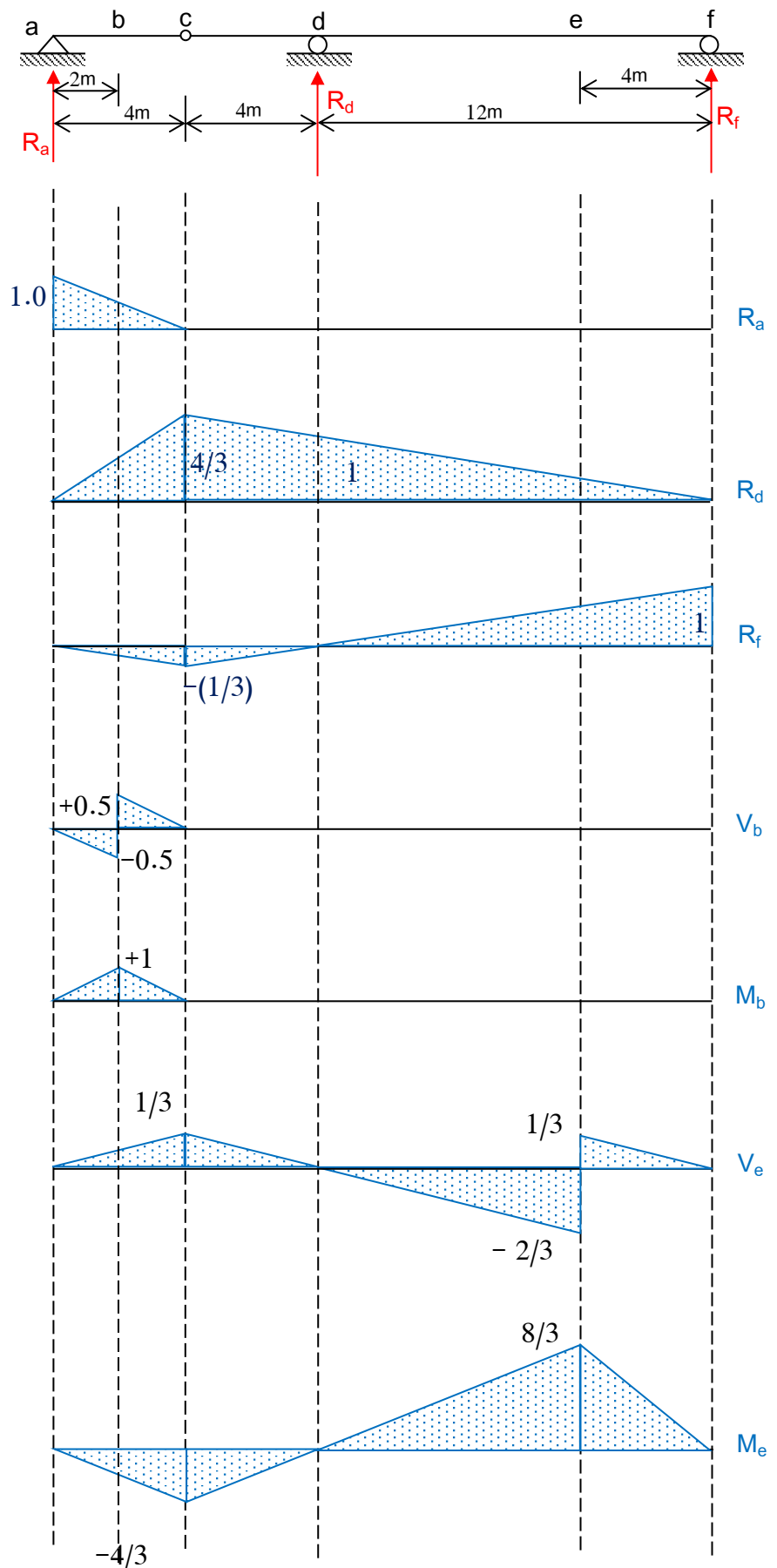

$$\sum F_y = 0 \text{ (whole beam)}$$

$$R_a + R_f + R_d - 1 = 0$$

$$0 + R_f + \frac{20-x}{12} - 1 = 0$$

$$R_f = \frac{x-8}{12}$$

Influence lines for V_b and M_b

For the load between “ a “ and “ b “ ;

$$V_b = R_a - 1 = \frac{4-x}{4} - 1$$

$$= - (R_d + R_f) = \frac{-x}{4}$$

$$M_b = 2R_a - 1(2-x) = (6 R_d + 18R_f)$$

$$= 2 \times \frac{4-x}{4} - (2-x) = \frac{x}{2}$$

For the load between “ b “ and “ c “ ;

$$V_b = R_a = 1 - (R_d + R_f) = \frac{4-x}{4}$$

$$M_b = 2R_a = (6 R_d + 18R_f) - (x - 2) = \frac{4-x}{2}$$

For the load between “ c “ and “ f “ ;

$$V_b = R_a = 1 - (R_d + R_f) = 0$$

$$M_b = 2R_a = (6 R_d + 18R_f) - (x - 2) = 0$$

Influence lines for V_e and M_e

For the load between “ a “ and “ c “ ;

$$V_e = R_a + R_d - 1 = - R_f = \frac{x}{12}$$

Theory of Structures

$$M_e = 16R_a + 8R_d - 1(16 - x) = 4 R_f = - \frac{x}{3}$$

For the load between “ c “ and “ e “ ;

$$V_e = R_a + R_d - 1 = - R_f = - \frac{x-8}{12}$$

$$M_e = 16R_a + 8R_d - 1(16 - x) = 4 R_f = \frac{x-8}{3}$$

For the load between “ e “ and “ f “ ;

$$V_e = R_a + R_d = 1 - R_f = \frac{20-x}{12}$$

$$M_e = 16R_a + 8R_d = 4 R_f - 1 (x - 16) = 8 \left(\frac{20-x}{12} \right)$$

Influence Lines for Trusses

Trusses are frequently loaded with moving loads as in the case of bridges. In order to design individual truss members, it is necessary to know the largest tensile or compressive force they must sustain as the loading moves across the structure.

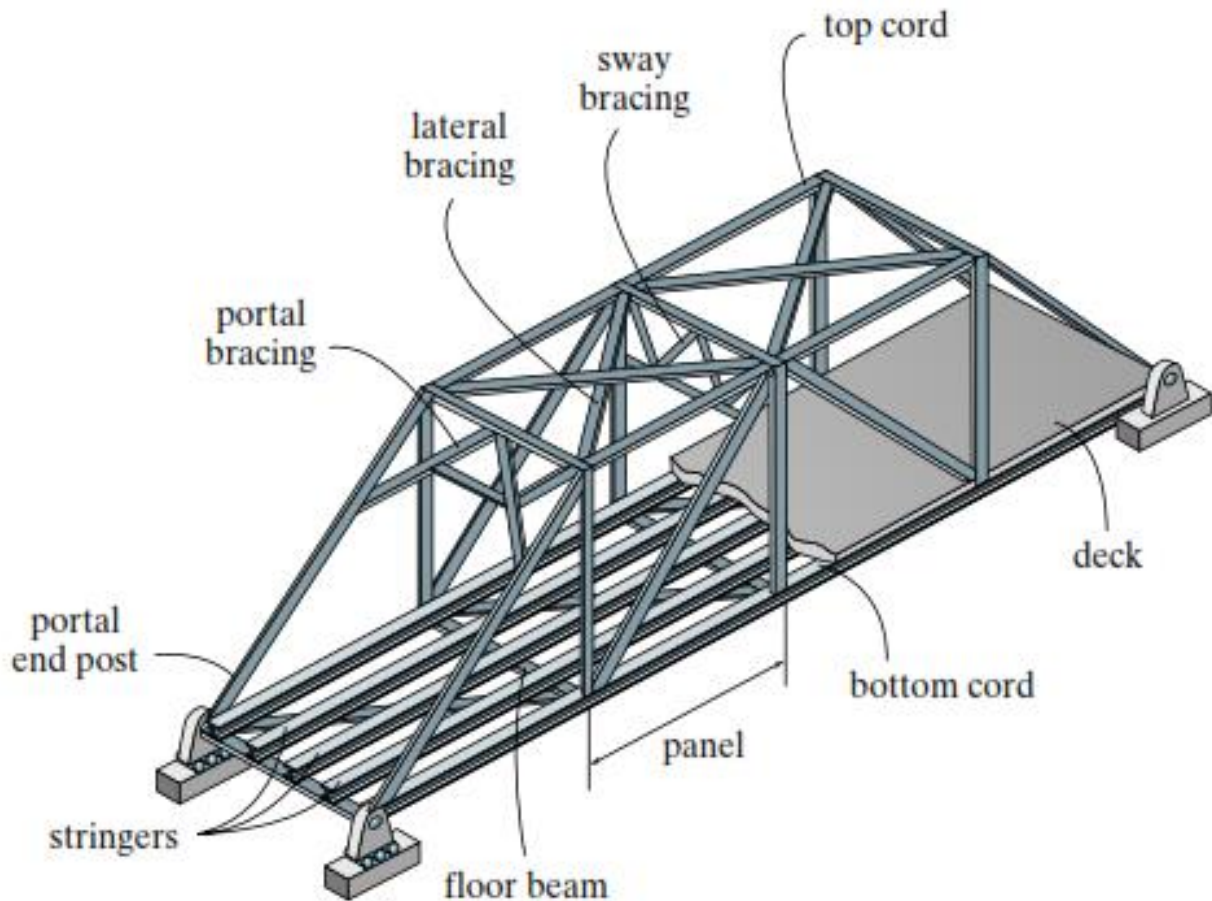

For the typical bridge truss shown in Figure above, the loading on the bridge deck is transmitted to stringers, which in turn transmit the loading to floor beams and then to the points along the bottom cord of the truss. Thus, the trusses in this case will be loaded only at points where the floor beams attached to the bottom cord of the truss. These points are termed "joints" or "panel points".

Example (1): Draw the influence lines for the members; ab, ac, bc, be, ce, and bd for the truss shown.

Solution

For the whole truss

$$\sum M_h = 0 \text{ [for whole truss] } \Rightarrow R_a = \frac{24-x}{24}$$

$$\sum M_a = 0 \Rightarrow \text{[for whole truss] } \Rightarrow R_h = \frac{x}{24}$$

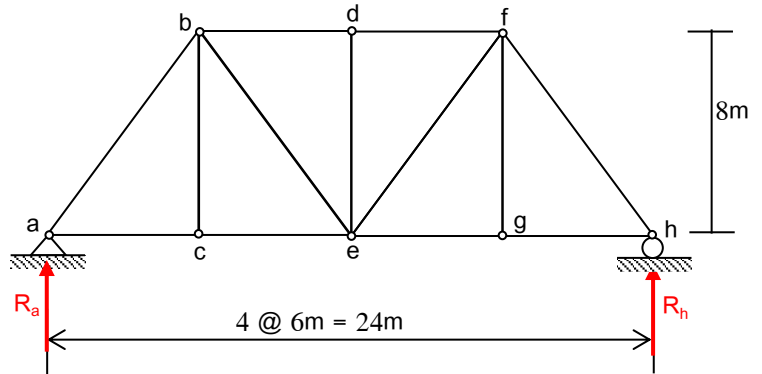

Influence lines for F_{ab} and F_{ac}

From F.B.D. for Joint " a "

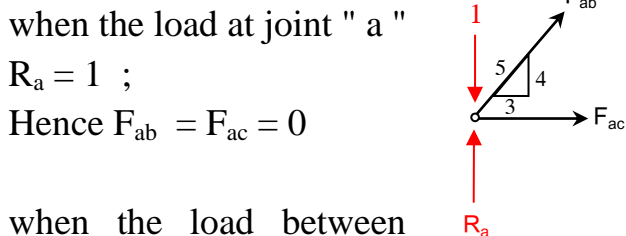

when the load between " c " and " h " ;

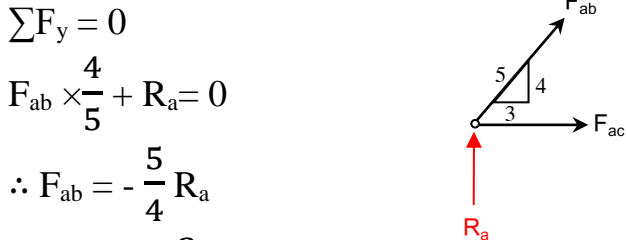

$\sum F_x = 0 \Rightarrow \frac{3}{5} F_{ab} + F_{ac} = 0$

$F_{ac} = -\frac{3}{5} F_{ab}$

x	R_a	F_{ab}	F_{ac}
0	1	0	0
6	0.75	-0.94	0.56
12	0.50	-0.63	0.38

Influence lines for F_{bc} and F_{ce}

From F.B.D. for Joint " c "

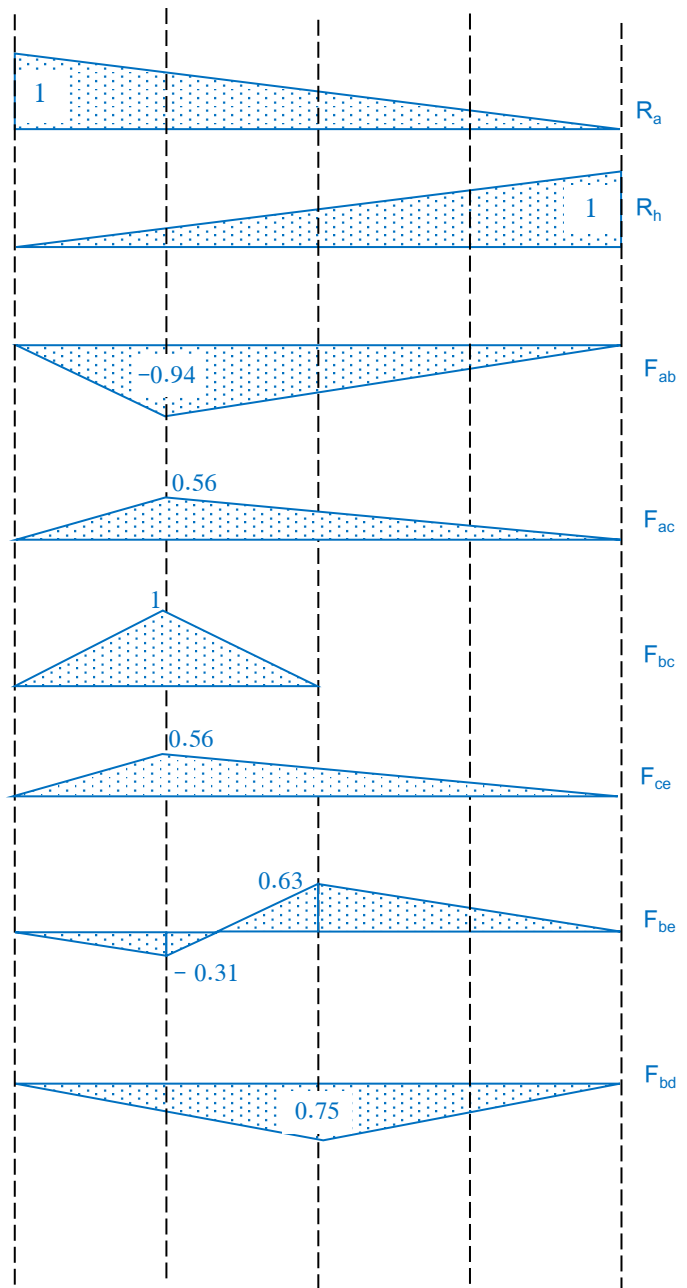
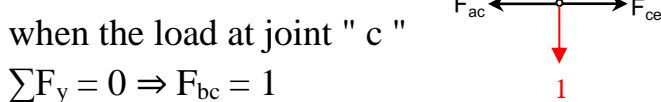

Theory of Structures

when the load at any joint except " c "

$$F_{bc} = 0$$

when the load at any joint

$$\sum F_x = 0 \Rightarrow F_{ac} = F_{ce}$$

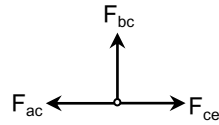

x	\$F_{ac}\$	\$F_{ac}\$	\$F_{ce}\$
0	0	0	0
6	1	0.56	0.56
12	0	0.38	0.38
18	0	0.19	0.19
24	0	0	0

Influence lines for \$F_{be}\$ and \$F_{bd}\$

From F.B.D. for Joint " b "

when the load between joint "

a " and " h "

$$\sum F_y = 0 \Rightarrow \frac{4}{5}F_{ab} + F_{bc} + \frac{4}{5}F_{be} = 0$$

$$F_{be} = -\frac{5}{4} \left(\frac{4}{5}F_{ab} + F_{bc} \right)$$

x	\$F_{ab}\$	\$F_{bc}\$	\$F_{be}\$	\$F_{bd}\$
0	0	0	0	0
6	-0.94	1	-0.31	-0.37
12	-0.63	0	0.63	-0.75
18	-0.31	0	0.31	-0.37
24	0	0	0	0

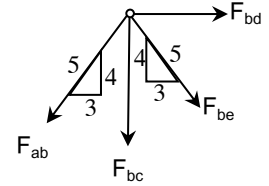

$$\sum F_x = 0 \Rightarrow -\frac{3}{5}F_{ab} + \frac{3}{5}F_{be} + F_{bd} = 0$$

$$F_{bd} = \frac{3}{5}F_{ab} - \frac{3}{5}F_{be}$$

Example (2): The truss has the vehicle load applied to the bottom panel points. Draw the influence lines for reactions R_a , R_g , ab , ac , bc , bd , cd , and ce .

Solution

For the whole truss

$$\sum M_g = 0 \text{ [for whole truss] } \Rightarrow R_a = \frac{6-x}{6}$$

$$\sum M_a = 0 \Rightarrow \text{ [for whole truss] } \Rightarrow R_g = \frac{x}{6}$$

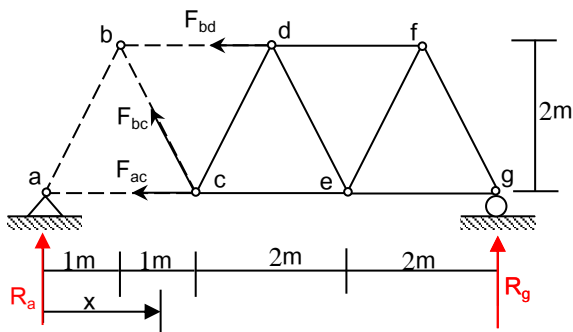
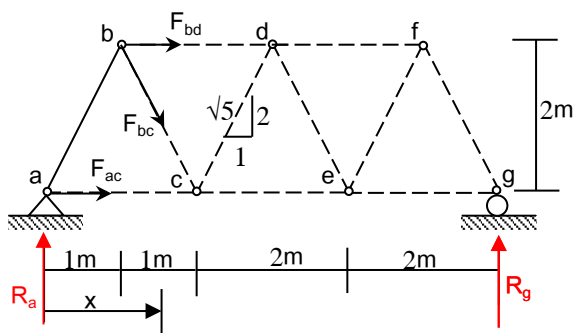

For section 1-1

when the load at joint " a "

$$\sum M_c = 0 \text{ [for right part]}$$

$$4R_g + 2F_{bd} = 0 \Rightarrow F_{bd} = -2R_g = 0$$

$$\sum M_b = 0 \text{ [for right part]}$$

$$5R_g - 2F_{ac} = 0 \Rightarrow F_{ac} = \frac{5}{2} R_g = 0$$

$$\sum F_y = 0 \text{ [for right part]}$$

$$R_g + \frac{2}{\sqrt{5}}F_{bc} = 0 \Rightarrow F_{bc} = -\frac{\sqrt{5}}{2} R_g = 0$$

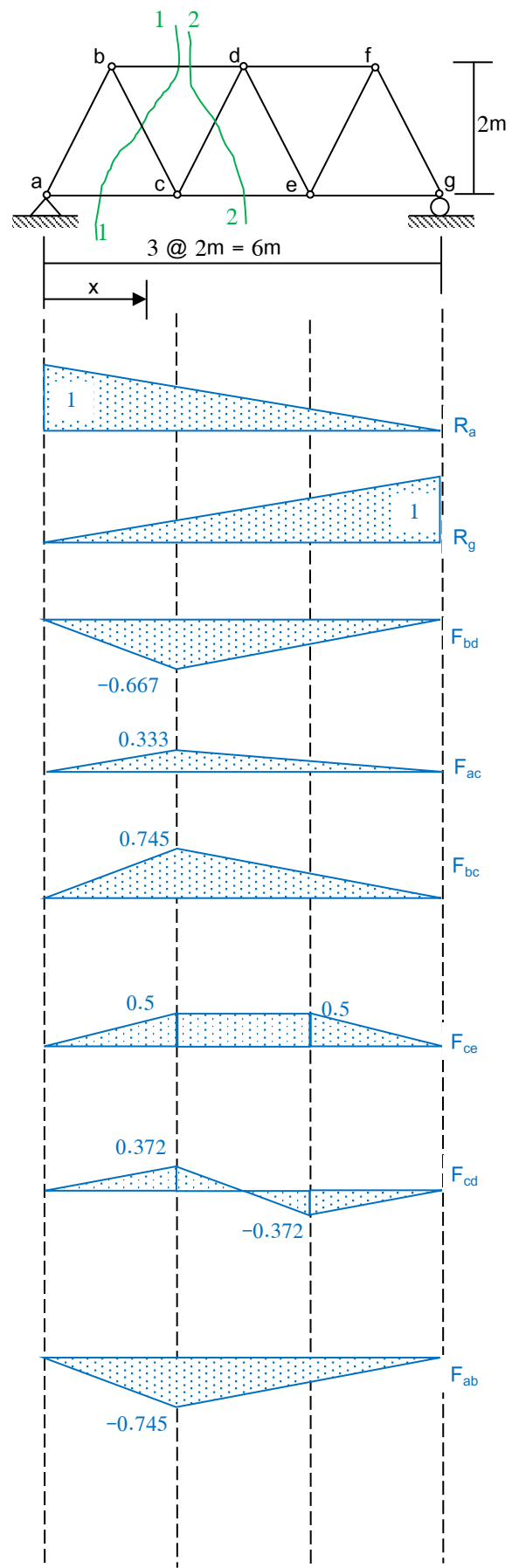

Theory of Structures

when the load between " c " and " g "

$$\sum M_c = 0 \text{ [for left part]}$$

$$2R_a + 2F_{bd} = 0 \Rightarrow F_{bd} = - R_a = - \frac{6-x}{6}$$

$$\sum M_b = 0 \text{ [for left part]}$$

$$R_a - 2F_{ac} = 0 \Rightarrow F_{ac} = \frac{R_a}{2} = \frac{6-x}{12}$$

$$\sum F_y = 0 \text{ [for left part]}$$

$$R_a - \frac{2}{\sqrt{5}}F_{bc} = 0 \Rightarrow F_{bc} = \frac{\sqrt{5}}{2} R_a = \frac{\sqrt{5}}{12} (6 - x)$$

For section 2-2

when the load between " a " and " c "

$$\sum M_d = 0 \text{ [for right part]}$$

$$3R_g - 2F_{ce} = 0 \Rightarrow F_{ce} = \frac{3}{2} R_g = \frac{x}{4}$$

$$\sum F_y = 0 \text{ [for right part]}$$

$$R_g - \frac{2}{\sqrt{5}}F_{cd} = 0 \Rightarrow F_{cd} = \frac{\sqrt{5}}{2} R_g = \frac{\sqrt{5} x}{12}$$

when the load between " e " and " g "

$$\sum M_d = 0 \text{ [for left part]}$$

$$3R_a - 2F_{ce} = 0 \Rightarrow F_{ce} = \frac{3}{2} R_a = \frac{6-x}{4}$$

$$\sum F_y = 0 \text{ [for left part]}$$

$$R_a + \frac{2}{\sqrt{5}}F_{cd} = 0 \Rightarrow F_{cd} = - \frac{\sqrt{5}}{2} R_a = - \frac{\sqrt{5} (6-x)}{12}$$

Influence lines for F_{ab}

From F.B.D. for Joint " a "

when the load at joint " a "

$$R_a = 1 ; \sum F_y = 0$$

$$F_{ab} \times \frac{2}{\sqrt{5}} - 1 + R_a = 0 ;$$

$$F_{ab} \times \frac{2}{\sqrt{5}} - 1 + 1 = 0 \Rightarrow F_{ab} = 0$$

when the load between " c " and " g " ;

$$\sum F_y = 0 ; F_{ab} \times \frac{2}{\sqrt{5}} + R_a = 0 \Rightarrow F_{ab} = - \frac{\sqrt{5}}{12} (6-x)$$

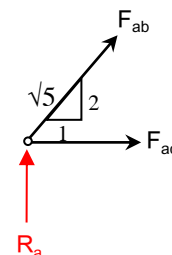
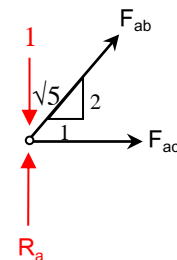
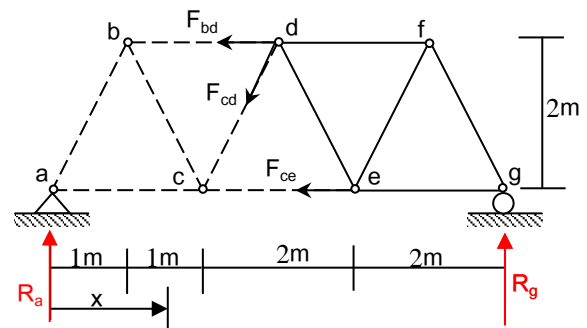
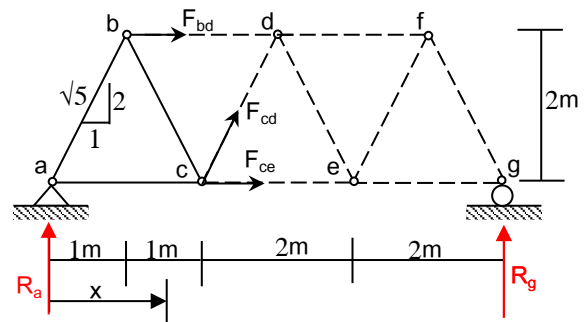

Moving Loads on Beams

Large vehicles, such as trucks or Lorries moving on a beam, impose a series of concentrated loads separated by fixed distances.

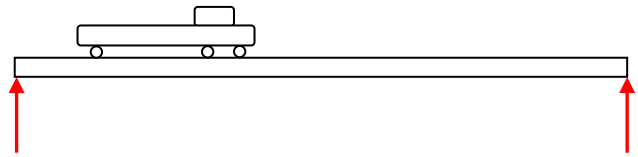

In order to design the beam, it is necessary to know the maximum shear and moment caused by the loads. This is possible only if it is known where the loading should be placed on the beam to cause maximum effect.

Absolute Maximum Moment in a Beam

For the beam subjected to a series of concentrated loads, the bending moment diagram consists of straight lines forming a polygon. Therefore, the section for maximum moment must be under one of the loads.

Consider a series of concentrated loads; P_1 , P_2 , P_3 , and P_4 separated by fixed distances, moving on a beam as shown in the figure.

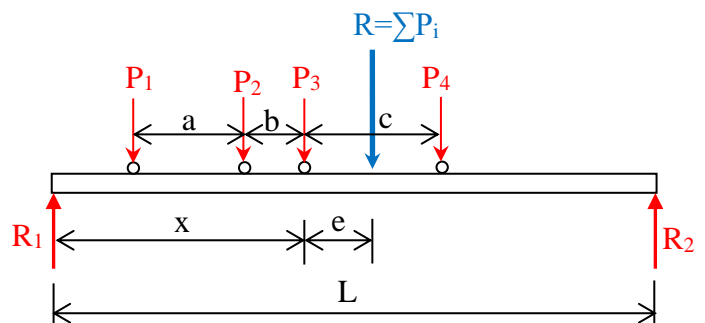

Suppose it is required to find the position of the section under the load P_3 in which maximum bending moment occurs.

Assuming a position of the loads such that the load under P_3 is at a distance " x " from R_1 .

Let $R = \sum P_i$ be the resultant of the loads and " e " its distance from P_3 , such that;

$$e = \frac{\sum P_i e_i}{R}$$

The bending moment at the section under P_3 is;

$$M_3 = R_1 \cdot x - P_1 (a + b) - P_2 \cdot b$$

From $\sum M = 0$ about R_2

$$R_1 = \frac{R}{L} (L - e - x)$$

Therefore,

$$\begin{aligned} M_3 &= \frac{R}{L} (L - e - x) \cdot x - P_1 (a + b) - P_2 \cdot b \\ &= \frac{R}{L} (L \cdot x - e \cdot x - x^2) - P_1 (a + b) - P_2 \cdot b \end{aligned}$$

For maximum value of M_3 ;

$$\frac{dM_3}{dx} = \frac{R}{L} (L - e - 2x) = 0$$

$$(L - e - 2x) = 0$$

$$x = \frac{L - e}{2}$$

This means that the section for maximum bending under the load P_3 is when the loads are positioned such that the beam centerline is at the midpoint between P_3 and the resultant of the loads.

As a general rule, though, the absolute maximum moment often occurs under the largest force lying nearest the resultant force of the system.

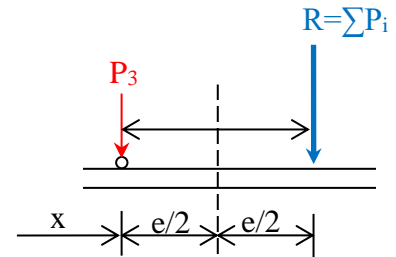

Absolute Maximum Shear

For a simply supported beam, the shear force is maximum at the ends (near the reactions). Therefore, it is necessary to maximize these reactions by positioning the loads as close as possible.

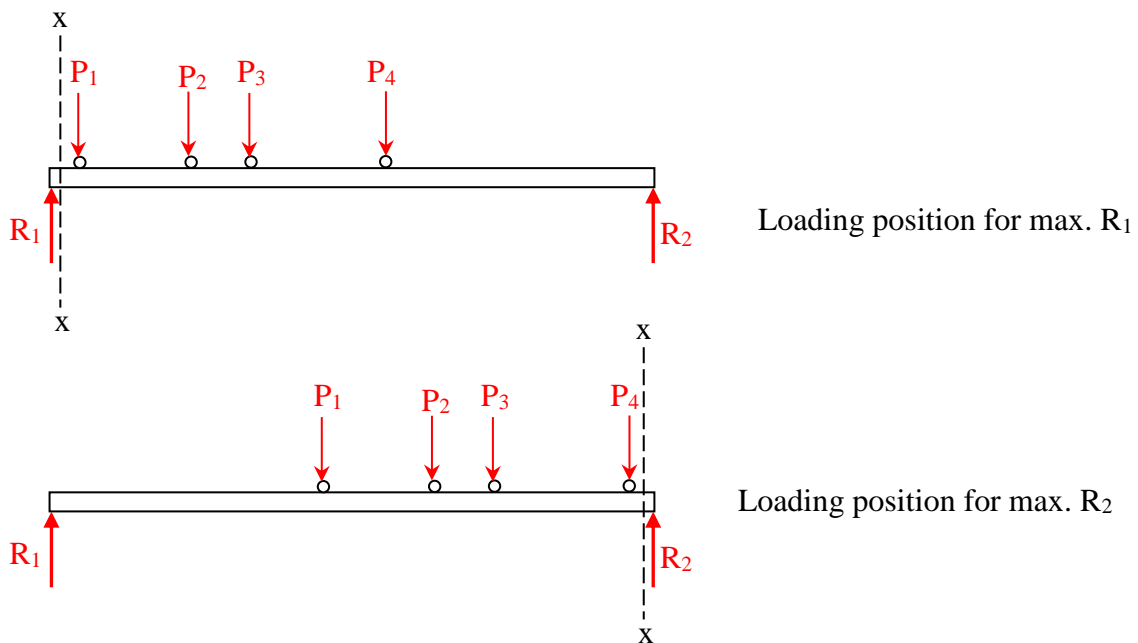

Example: Three wheel loads move on a beam of span 30m as shown in figure. Find the absolute maximum moment and shear for the beam.

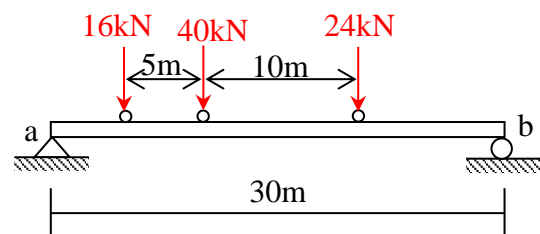

Solution

The resultant of the applied load is between wheel (2) and (3)

$$R = 16 + 40 + 24 = 80\text{kN}$$

To find the distance " y " from wheel (3) to the resultant, hence;

$$y = \frac{16 \times 15 + 40 \times 10}{80} = 8\text{m}$$

The maximum moment will occur under wheel (2).

According to the criterion for absolute maximum moment, the wheel (2) and the resultant should be placed equidistant from the centerline of the beam.

$$\sum M_b = 0$$

$$R_a = \frac{80 \times 14}{30} = 37.33\text{kN}$$

$$\sum M_b = 0$$

$$R_b = 80 - 37.33 = 42.67\text{kN}$$

$$M_{\text{max.}} = R_a \times 14 - 16 \times 5$$

$$= 37.33 \times 14 - 80 = 442.62 \text{ kN.m}$$

8m

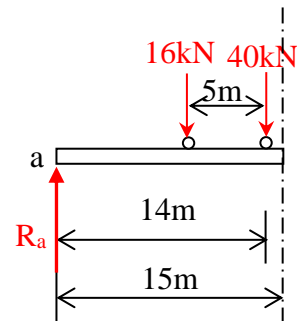
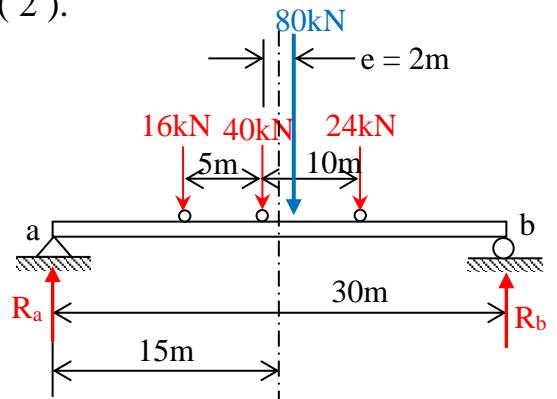
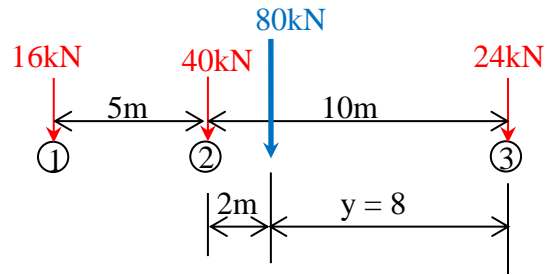

The maximum shear will occur near a reaction and is obtained by positioning the wheels as shown.

Thus with resultant as close as possible to one support and all wheels on the structure;

$$\sum M_b = 0$$

$$R_a = \frac{80 \times 23}{30} = 61.33\text{kN}$$

$$V_{\text{max.}} = R_a = 61.33\text{kN}$$

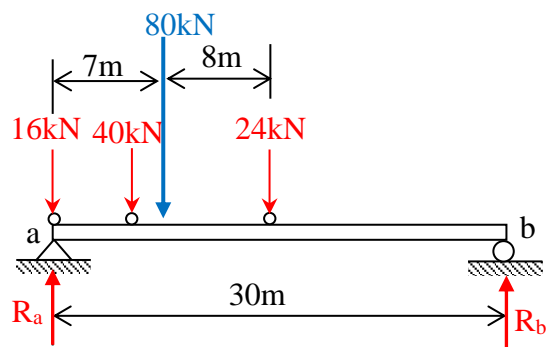

Chapter Six

Beam Deflections

Deflection of a Beam

The deformation which occur in a beam is expressed in terms of the " deflections " of the beam from its original unloaded configuration. Deflection is measured from the original position of the neutral surface to the neutral surface of the deformed beam.

The deformed shape taken by the neutral surface is known as the " elastic curve " of the beam.

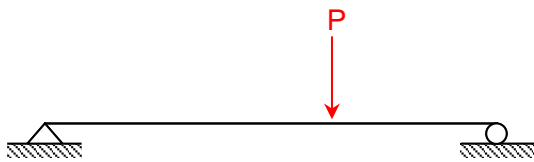

Fig. (a)

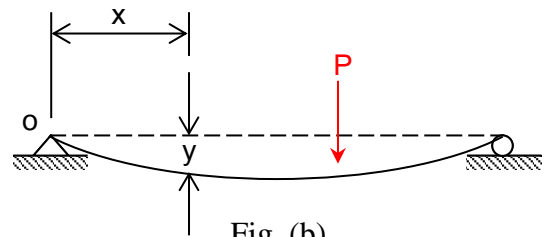

Fig. (b)

Figure (a) represents the beam in its original configuration, whereas Fig. (b) represents the deflected shape of the beam due to the applied loads.

The displacement " y " is known as " beam deflection ". it is often required to determine the deflection " y " for all values of " x " along the beam. This relationship may be written as an equation which is termed as the equation of the " deflection curve " or " elastic curve " of the beam.

Significance of Beam Deflections

Design specifications for beams usually impose limits on deflections in addition to stresses, therefore its necessary to calculate stresses and deflections for the design of beams, i.e. , a well-designed beam must not only be able to carry its imposed loading without failing. It should also not develop undesirable large deflections.

For example, in designing equipment for precision work, such as lathes, the deformations must be kept below the permissible tolerances of the work being machined. Floor beams carrying plastered ceilings beneath them are usually restricted to a maximum deflection of $\frac{1}{360}$ of their lengths in order to avoid cracks in the plaster.

And important application of beam deflections is to obtain equations with which, in combination with the conditions of static equilibrium, statically indeterminate beams can be analysed.

Methods for Determination of Beam Deflections

Several methods are available for the determination of deflections in beams. Among the most common are;

- i- **Double-integration method.**
- ii- **Singularity function (Macaulay) method.**
- iii- **Moment-area method.**
- iv- **Elastic energy methods.**

All above methods are applicable within the elastic range of behavior for beams.

Double-Integration Method

in derivation of the flexural formula, the following relation was obtained;

$$\frac{M}{I} = \frac{E}{\rho} \quad \text{----- (1)}$$

Where;

M is the bending moment at a given section of the beam.

I is the moment of inertia about the neutral axis.

E is the modulus of elasticity.

ρ is the radius of curvature.

Equation (1) may be rewritten as;

$$\frac{M}{EI} = \frac{1}{\rho} \quad \text{----- (2)}$$

EI is usually constant along beams and known as the " Flexural rigidity ".

$\frac{1}{\rho}$ is the curvature of the neutral surface of the beam.

From calculus;

$$\frac{1}{\rho} = \frac{\frac{d^2y}{dx^2}}{\left[1 + \left(\frac{dy}{dx}\right)^2\right]^{\frac{3}{2}}} \quad \text{----- (3)}$$

In the above expression, $\frac{dy}{dx}$ represents the slope of the elastic curve at any given point, for small deflections, the slope is very small, and its square is negligible compared with unity, and hence

$$\frac{1}{\rho} \approx \frac{d^2y}{dx^2} \quad \text{----- (4)}$$

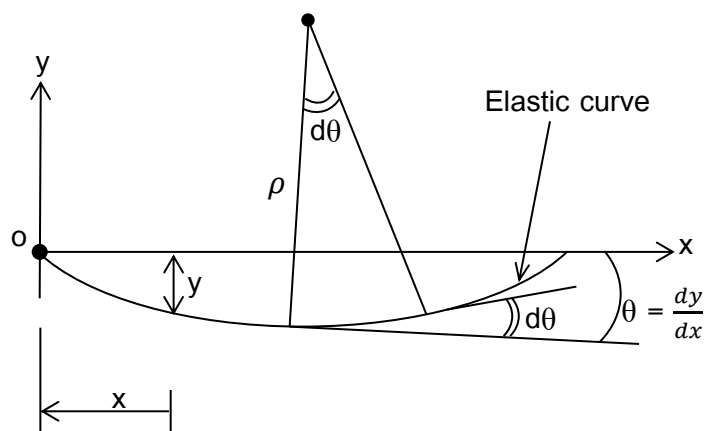

Substituting in Eq. (2) we finally obtain;

$$\frac{M}{EI} = \frac{d^2y}{dx^2}$$

or $M = EI \frac{d^2y}{dx^2}$ ----- (5)

This is known as the differential equation of the elastic curve of a beam.

Solution Procedure

The double-integration method for determination of beam deflections involves two integrations of Eq. (5). The first integration gives the slope $\theta = \frac{dy}{dx}$ at any point along the beam and the second integration gives the deflection " y " for any value of " x ". The bending moment " M " must be expressed as a function of " x " in order to perform the integration.

Since the differential Eq. (5) is of the second order, its solution must contain two constants of integration. These constants are determined from known conditions regarding the slope or deflection at given points on the beam, for example, in the case of a cantilever, both slope and the deflection are equal to zero at fixed end.

It is necessary in some cases to use two (or more) equations to describe the bending moment for different regions along the beam. In such cases Eq. (5) must be written for each region of the beam and the integration of such equations results of two integrations constants for each region. The constants of integration are then determined from conditions of continuity of slope and deflection at the common points between adjacent regions.

Sign Convention

The sign convention for the bending moment " M " will be the same as used in the previous chapters. The positive x-direction is taken towards the right along the beam, and upward deflections are considered positive, whereas downward deflections are considered negative.

Example (1): Determine the equations of slope and deflection for the cantilever of length (L) subjected to a concentrated load (P) at its free end.

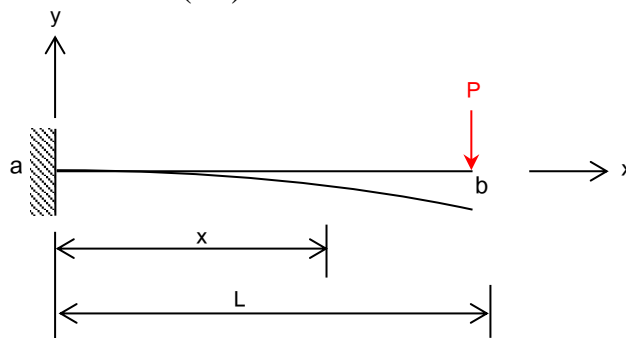

Solution



$$\sum F_y = 0 \Rightarrow R_a = P$$

$$\sum M_a = 0 \Rightarrow M_a = PL$$

The bending moment at a section " x " is;

$$M = -M_a + R_a \cdot x = -PL + Px$$

The differential equation of the bent beam is;

$$EI \frac{d^2y}{dx^2} = M$$

Substituting for M

$$EI \frac{d^2y}{dx^2} = -PL + Px \quad \text{----- (1)}$$

$$\text{Integrating; } EI \frac{dy}{dx} = -PLx + \frac{1}{2}Px^2 + C_1 \quad \text{----- (2)}$$

which represents the expression for slope along the cantilever.

To evaluate C_1 , the slope at the fixed end equals zero;

$$\left(\frac{dy}{dx} \right)_{x=0} = 0 = C_1 \Rightarrow C_1 = 0$$

$$EI \frac{dy}{dx} = -PLx + \frac{1}{2}Px^2 \quad \text{----- (3)}$$

$$\text{Integrating again; } EI y = -PL \cdot \frac{x^2}{2} + \frac{1}{6}Px^3 + C_2 \quad \text{----- (4)}$$

To evaluate C_2 , the deflection at the fixed end equals zero;

$$(y)_{x=0} = 0 = C_2 \Rightarrow C_2 = 0$$

$$EI y = -PL \cdot \frac{x^2}{2} + \frac{1}{6}Px^3 \quad \text{----- (5)}$$

Equations (3) and (5) give the slope and deflection respectively at any point " x " along the cantilever.

At the free end ($x = L$), both the slope and deflection are maximum and are given by;

$$EI \left(\frac{dy}{dx} \right)_{x=L} = -PL^2 + \frac{1}{2}PL^2$$

$$\left(\frac{dy}{dx}\right)_{x=L} = -\frac{PL^2}{2EI}$$

$$EI (y)_{x=L} = -PL \cdot \frac{L^2}{2} + \frac{1}{6} PL^3$$

$$(y)_{x=L} = y_{\max.} = -\frac{PL^3}{3EI} \text{ (downward)}$$

For $L = 3\text{m}$, $P = 50\text{kN}$, $E = 200\text{GPa}$, and $I = 300 \times 10^6 \text{mm}^4$

$$\left(\frac{dy}{dx}\right)_{x=3\text{m}} = -\frac{50 \times 10^3 \times (3000)^2}{2 \times 200 \times 10^3 \times 300 \times 10^6} = -0.00375 \text{ rad}$$

$$(y)_{x=3\text{m}} = -\frac{50 \times 10^3 \times (3000)^3}{3 \times 200 \times 10^3 \times 300 \times 10^6} = -7.5 \text{mm}$$

Example (2): Determine the equations of the elastic curve for the simply supported beam of span (L) subjected to a concentrated load " P " as shown in the figure.

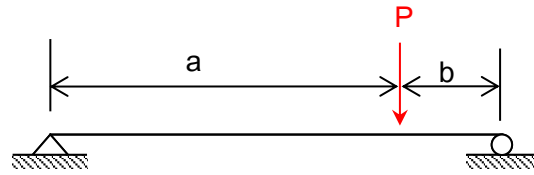

Solution

For $0 < x < a$

$$M = \frac{Pb}{L} \cdot x$$

Equation of the bent beam is;

$$EI \frac{d^2y}{dx^2} = \frac{Pb}{L} \cdot x \quad \text{----- (1)}$$

By integrating; $EI \frac{dy}{dx} = \frac{Pb}{2L} \cdot x^2 + C_1 \quad \text{----- (2)}$

Integrating again; $EI \cdot y = \frac{Pb}{6L} \cdot x^3 + C_1 \cdot x + C_2 \quad \text{----- (3)}$

At $x = 0$; deflection = 0 ; From Eq. (3) $\Rightarrow y = 0 \Rightarrow C_2 = 0$

Hence, the elastic curve is; $EI \cdot y = \frac{Pb}{6L} \cdot x^3 + C_1 \cdot x \quad \text{----- (4)}$

For $a < x < L$

$$M = \frac{Pb}{L} \cdot x - P(x - a)$$

$$EI \frac{d^2y}{dx^2} = \frac{Pb}{L} \cdot x - P(x - a) \quad \text{----- (5)}$$

By integrating; $EI \frac{dy}{dx} = \frac{Pb}{2L} \cdot x^2 - \frac{P(x-a)^2}{2} + C_3 \quad \text{----- (6)}$

Integrating again; $EI \cdot y = \frac{Pb}{6L} \cdot x^3 - \frac{P(x-a)^3}{6} + C_3 \cdot x + C_4 \quad \text{----- (7)}$

At $x = L$; deflection = 0 ; From Eq. (7) $\Rightarrow y = 0$;

$$\frac{PbL^2}{6} - \frac{P(L-a)^3}{6} + C_3 \cdot L + C_4 = 0$$

Hence, $C_3 \cdot L + C_4 = \frac{Pb^3}{6} - \frac{PbL^2}{6} \quad \text{----- (8)}$

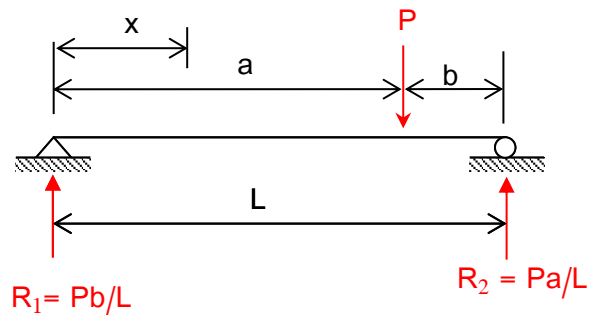

From Eq. (2); slope at $x = a$, $EI \left(\frac{dy}{dx} \right)_{x=a} = \frac{Pb}{2L} \cdot a^2 + C_1$

From Eq. (6); slope at $x = a$, $EI \left(\frac{dy}{dx} \right)_{x=a} = \frac{Pb}{2L} \cdot a^2 + C_3$

Due to continuity, the above expressions for slope at ($x = a$) must be equal,

$$\frac{Pb}{2L} \cdot a^2 + C_3 = \frac{Pb}{2L} \cdot a^2 + C_1 \quad ; \quad \text{Hence} \quad C_3 = C_1 \quad \text{----- (9)}$$

From Eq. (4); deflection at $x = a$, $EI \cdot (y)_{x=a} = \frac{Pba^3}{6L} + C_1 \cdot a$

From Eq. (7); deflection at $x = a$, $EI \cdot (y)_{x=a} = \frac{Pba^3}{6L} + C_3 \cdot a + C_4$

Due to continuity, the above expressions for deflection at ($x = a$) must be equal,

$$\frac{Pba^3}{6L} + C_1 \cdot a = \frac{Pba^3}{6L} + C_3 \cdot a + C_4 \quad \text{----- (10)}$$

From Eqs. (9) and (10) $\Rightarrow C_4 = 0$

From Eq. (8); $\Rightarrow C_3 = \frac{Pb^3}{6L} - \frac{PbL}{6} = \frac{Pb}{6L} (b^2 - L^2)$

Substituting in Eqs. (4) and (7), respectively;

$$EI \cdot y = \frac{Pb}{6L} \cdot x^3 + \frac{Pb}{6L} (b^2 - L^2) \cdot x = \frac{Pb}{6L} [x^3 - (L^2 - b^2) \cdot x] \quad \text{For } 0 < x < a$$

$$EI \cdot y = \frac{Pb}{6L} \cdot x^3 - \frac{P(x-a)^3}{6} + \frac{Pb}{6L} (b^2 - L^2) \cdot x = \frac{Pb}{6L} \left[x^3 - \frac{L}{b} (x-a)^3 - (L^2 - b^2) \cdot x \right]$$

For $a < x < L$

Example (3): Determine the displacement at point C in the beam shown in the figure.

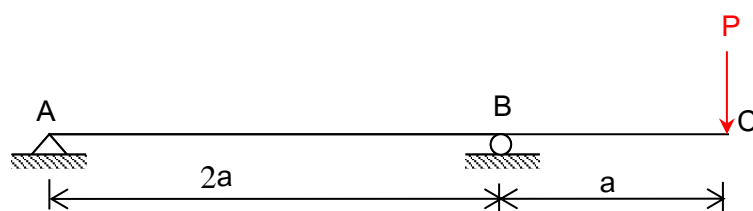

EI = Constant

The Moment - Area Method

Consider a segment of the elastic curve of a beam shown in figure in a general deformed shape.

This member was initially straight and continuous.

For a small angle $d\theta$,

$$R \cdot d\theta = dx$$

or
$$d\theta = \frac{1}{R} \cdot dx$$

Integrating between the two points x_a and x_b .

$$\theta_{ba} = \int_{x_a}^{x_b} \frac{1}{R} \cdot dx$$

For an elastic beam;

$$\frac{1}{R} = \frac{M}{EI}$$

Therefore,

$$\theta_{ba} = \int_{x_a}^{x_b} \frac{M}{EI} \cdot dx$$

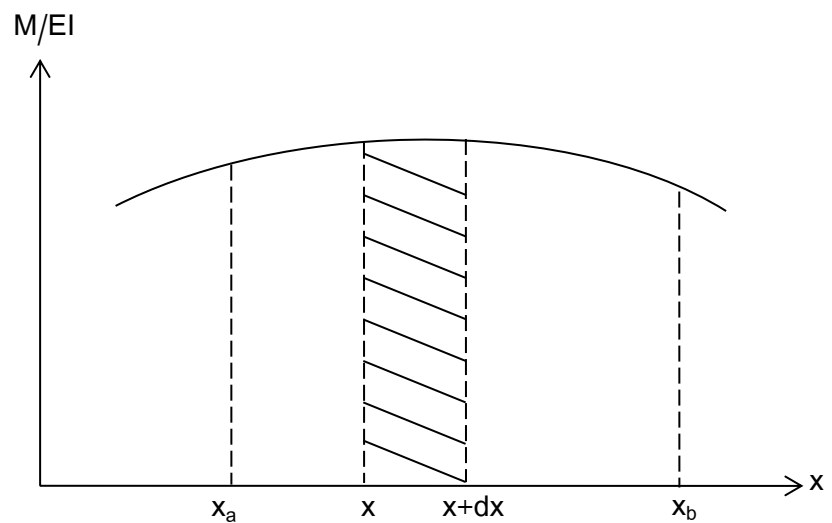
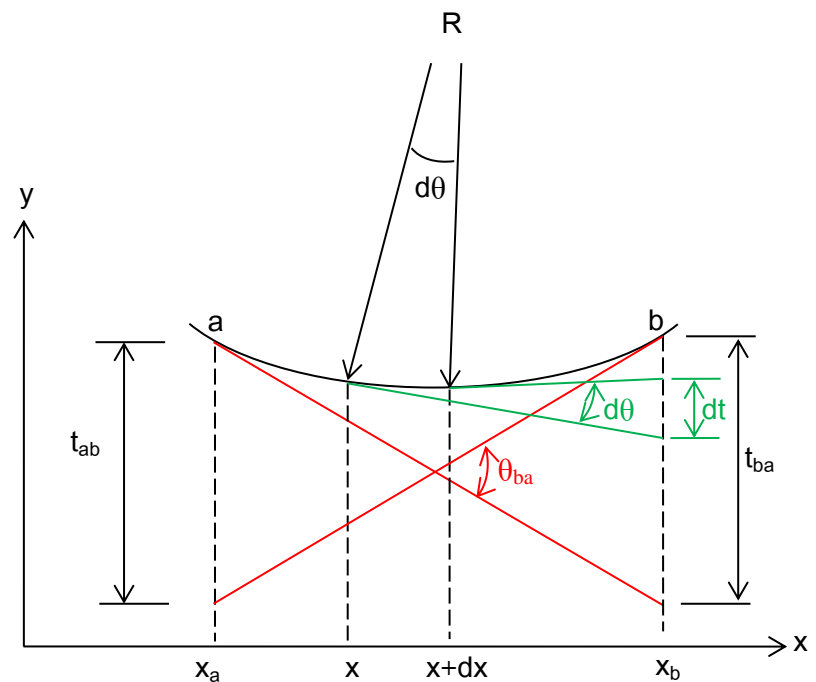

The right-hand side of the above equation represents the area under the $\frac{M}{EI}$ diagram between x_a and x_b , and the left-hand side is the change in slope of the tangents at points x_a and x_b . This equation is the statement of the first moment-area theorem.

First-Moment Area Theorem: The change in slope between the tangents of the elastic curve at two points is equal to the area of the $\frac{M}{EI}$ diagram between the two points.

Consider the tangents to the elastic curve in figure, at two points along the beam located at x and $x+dx$. The change in the slope over this small length of beam is $d\theta$.

Let (dt) is the vertical deviation of the tangents on each side of the differential element dx, this deviation is measured along a vertical line passing through x_b is.

For small angles $dt = (x_b - x) \cdot d\theta$

Substituting $d\theta = \frac{1}{R} dx$

Integrating between x_a and x_b ;

$$t_{ba} = \int_{x_a}^{x_b} dt = \int_{x_a}^{x_b} (x_b - x) \frac{1}{R} dx$$

The tangential deviation t_{ba} is the deflection at x_b measured relative to the tangent at x_a .

For an elastic beam $\frac{1}{R} = \frac{M}{EI}$

Therefore; $t_{ba} = \int_{x_a}^{x_b} (x_b - x) \frac{M}{EI} dx$

The right-side of the equation is the first moment about x_b of the area under the $\frac{M}{EI}$ diagram between points x_a and x_b .

Second-Moment Area Theorem: The vertical deviation of the tangent at a point (b) on the elastic curve with respect to the tangent extended from another point (a) equals the “moment” of the area under the $\frac{M}{EI}$ diagram between the two points " a " and " b " taken about point " b ".

Sign Convention

The figure shows the algebraic signs of the slopes and tangent deviation distances for the moment-area method: a positive slope change implies an increase in the slope between the two points, and a tangent deviation is positive if the elastic curve lies above the tangent reference line; i.e., in the positive coordinate direction.

Theory of Structures

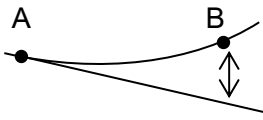

+ ve dev.

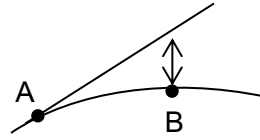

- ve dev.

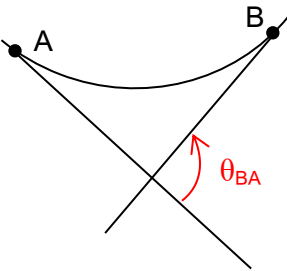

+ ve change of slope

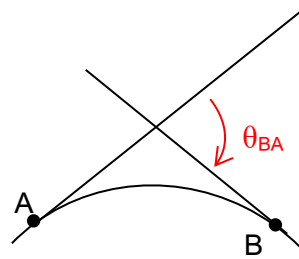

- ve change of slope

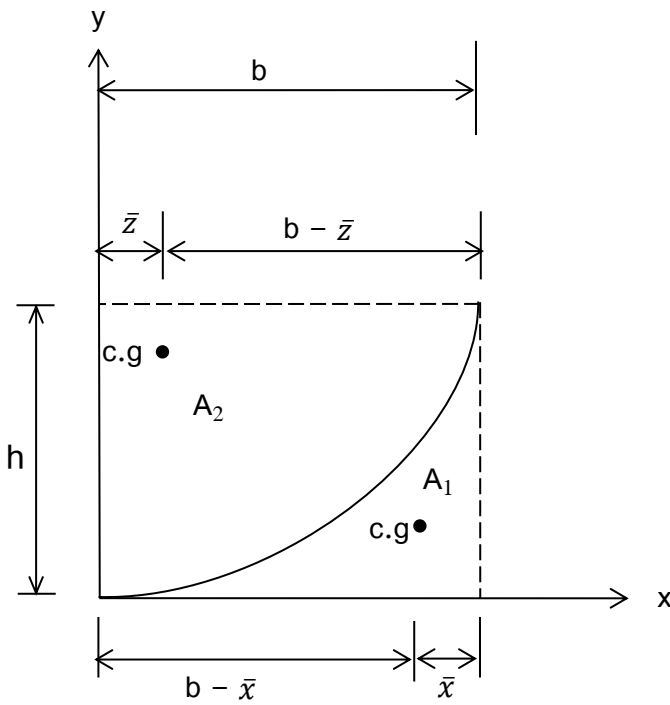

$$A_1 = \frac{1}{n+1} bh$$

$$\bar{x} = \frac{b}{n+2}$$

$$A_2 = bh - A_1$$

$$\bar{z} = \frac{b - \bar{x}}{2}$$

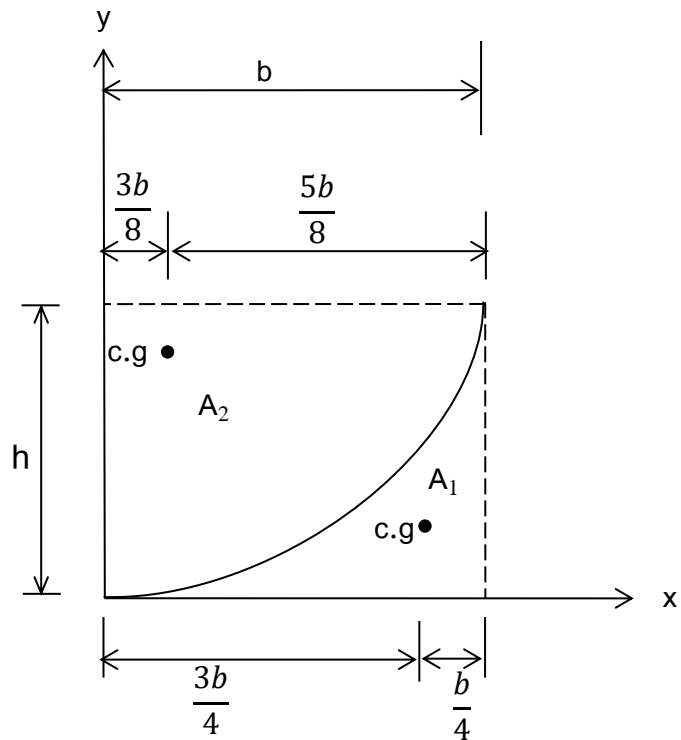

$$A_1 = \frac{1}{3} bh$$

$$\bar{x} = \frac{b}{4}$$

$$A_2 = \frac{2}{3} bh$$

$$\bar{z} = \frac{3b}{8}$$

Example (1): Use the Moment-Area method to calculate the slope and deflection at the free end of the cantilever shown in Figure.

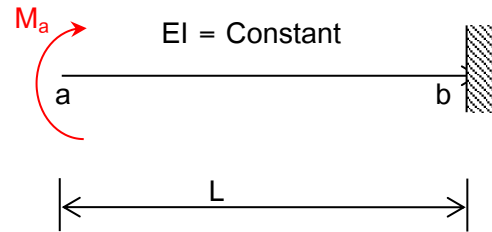

Solution

From the 1st moment-area theorem;

$$\theta_a = \theta_{ba} = \frac{1}{EI} M_a \cdot L$$

$$\theta_a = \frac{M_a \cdot L}{EI} \quad (\curvearrowleft)$$

From the 2nd moment-area theorem

$$t_{ab} = \Delta_a = \frac{1}{EI} (M_a \cdot L) \cdot \left(\frac{L}{2}\right) = \frac{M_a L^2}{2EI}$$

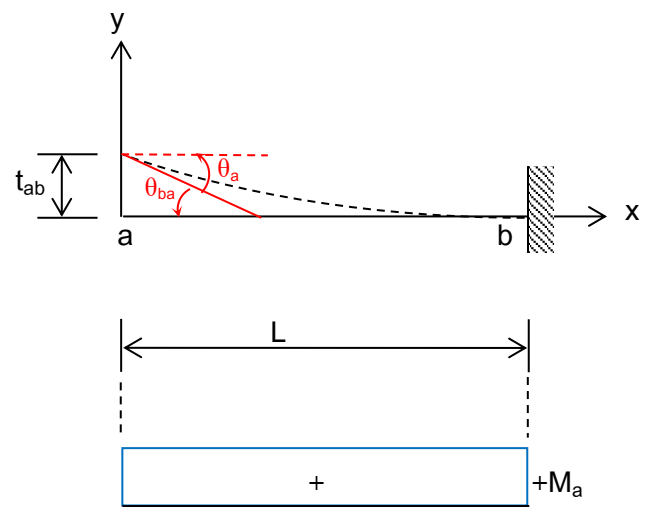

Example (2): Use the moment-area method to calculate the rotations and mid-span deflection for the simply supported beam subjected to a uniformly distributed load.

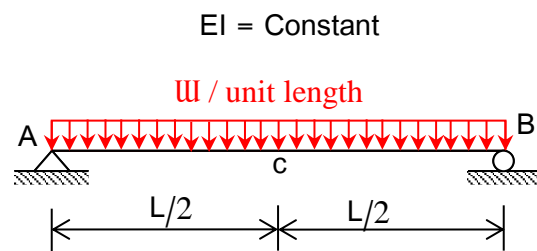

Solution

Applying 1st moment-area theorem;

$$\theta_{BA} = \theta_A + \theta_B \quad , \quad \theta_A = \theta_B \quad (\text{from symmetry})$$

$$\theta_{BA} = \frac{1}{EI} \left(\frac{2}{3} \cdot \frac{\omega L^2}{8} \cdot L \right) = \frac{1}{EI} \left(\frac{\omega L^3}{12} \right)$$

Theory of Structures

$$\theta_A = \frac{1}{2} \theta_{BA} = \frac{1}{24} \left(\frac{\omega L^3}{EI} \right) \quad (\curvearrowleft)$$

$$\theta_B = -\theta_A = -\frac{1}{24} \left(\frac{\omega L^3}{EI} \right) \quad (\curvearrowright)$$

From 2nd moment-area theorem

$$\Delta_C = t_{bc}$$

$$t_{bc} = \frac{1}{EI} \left(\frac{2}{3} \cdot \frac{\omega L^2}{8} \cdot \frac{L}{2} \right) \left(\frac{5}{8} \cdot \frac{L}{2} \right) = \frac{5}{384} \left(\frac{\omega L^4}{EI} \right)$$

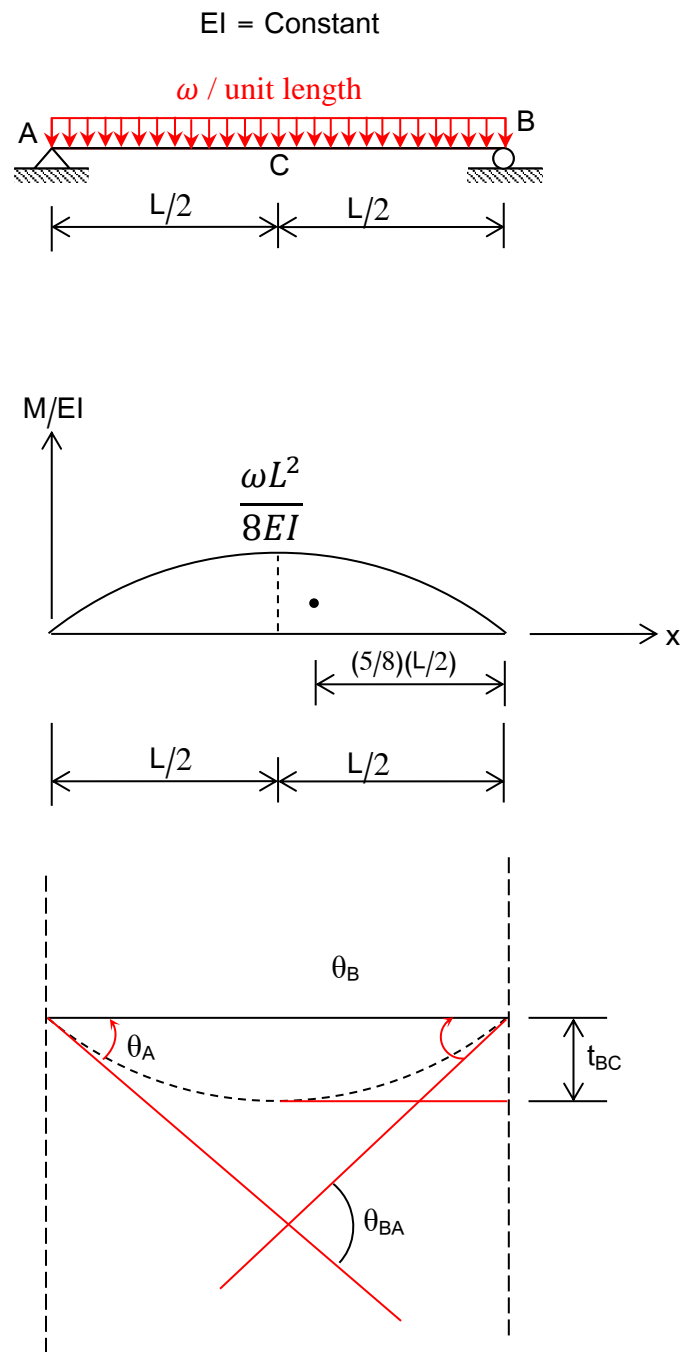

Example (3): Use the moment-area method to calculate the end slopes and deflection under the concentrated load for the simply supported beam shown in figure.

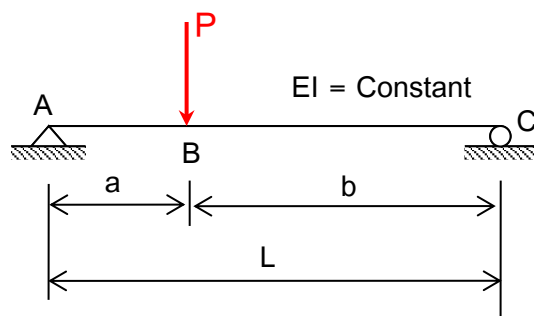

Chapter Seven

Force Methods

To analyse a linear elastic statically indeterminate structure, the concepts of static equilibrium must be combined with the procedures for calculating displacements. These two sets of principles are combined to give the " Force methods " .

In this approach, compatibility conditions (deflection constraint conditions) are enforced throughout the structure by superposing a set of partial solutions, all of which satisfy equilibrium, force deflection relations, and boundary conditions.

This results in a set of equations with forces as unknowns.

One of the widely used force methods is the " Method of Consistent Deformations " .

Method of Consistent Deformations

The method of consistent deformations involves invoking compatibility using various loading conditions for a statically determinate structure that is derived from the structure being investigated.

It may be considered to consist of five basic steps:

- 1- Remove reaction forces to make the remaining structure, called the " primary structure , statically determinate and stable.
- 2- Calculate the deflection caused by the actual loading on the primary structure at the location and along the line of action of the reaction component that was removed.
- 3- Applying the redundant reaction with all other loads removed.
- 4- Enforce the deflection constraints (Compatibility).
- 5- Calculate the Unknowns for the actual structure.

Example (1): Determine the reaction components and draw the shear force and bending moment diagrams for the beam shown in figure.

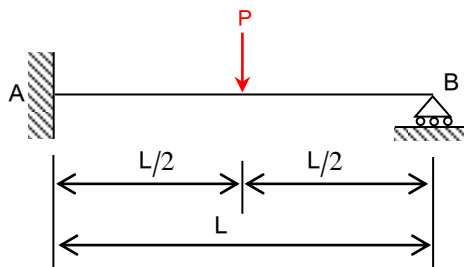

Solution

If the primary determinate beam is the cantilever beam AB, while the redundant is the vertical reaction at B (V_B). The compatibility condition is the deflection at B equals to zero.

The deflections Δ_{BP} and Δ_{BV} can be found by the moment-area theorem

$$(t_{AB})_P = \Delta_{BP} = \frac{-1}{EI} \left(\frac{1}{2} \times \frac{PL}{2} \times \frac{L}{2} \right) \left(\frac{L}{2} + \frac{2}{3} \times \frac{L}{2} \right) = \frac{5PL^3}{48EI}$$

$$(t_{AB})_V = \Delta_{BV} = \frac{1}{EI} \left(\frac{1}{2} \times V_B \cdot L \times L \right) \left(\frac{2}{3} \cdot L \right) = \frac{V_B L^3}{3EI}$$

$$-\Delta_{BP} + \Delta_{BV} = -\frac{5PL^3}{48EI} + \frac{V_B L^3}{3EI} = 0$$

$$V_B = \frac{5}{16} P \quad (\uparrow)$$

From statically equilibrium,

$$V_A = \frac{11}{16} P \quad (\uparrow)$$

$$M_A = \frac{P \cdot L}{2} - \frac{5P \cdot L}{16} = \frac{3P \cdot L}{16}$$

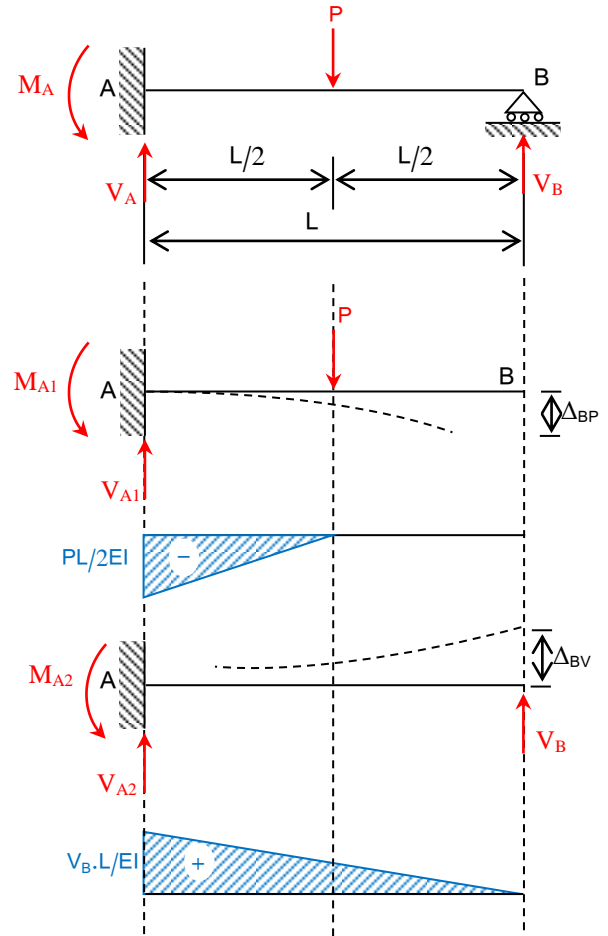

Example (2): Determine the reaction components and draw the shear force and bending moment diagrams for the beam shown in Figure. [$EI = \text{Constant}$]

Solution

The beam is fixed at both ends and it is statically indeterminate to the second degree.

From symmetry: $V_A = V_B = \omega L/2$

The only unknown is the fixed-end moment at each end; $M_A = M_B = M$

A simply supported beams AB is chosen as the primary determinate beam under action of the uniform load and the redundant is M;

The compatibility condition is

$$\theta_{A\omega} + \theta_{AM} = 0$$

Using 2st moment-area theorem;

$$t_{(BA)\omega} = \frac{1}{EI} \left(\frac{2}{3} \cdot \frac{\omega L^2}{8} \cdot L \right) \left(\frac{L}{2} \right) = \frac{\omega L^4}{24EI}$$

$$\Theta_{A\omega} = \frac{t_{(BA)\omega}}{L} = \frac{\omega L^3}{24EI}$$

$$t_{(BA)M} = \frac{-1}{EI} (M \cdot L) \left(\frac{L}{2} \right) = \frac{-ML^2}{2EI}$$

$$\theta_{AM} = \frac{t_{(BA)M}}{L} = \frac{-ML}{2EI}$$

$$\frac{\omega L^3}{24EI} - \frac{ML}{2EI} = 0 \Rightarrow M = \frac{\omega L^2}{12}$$

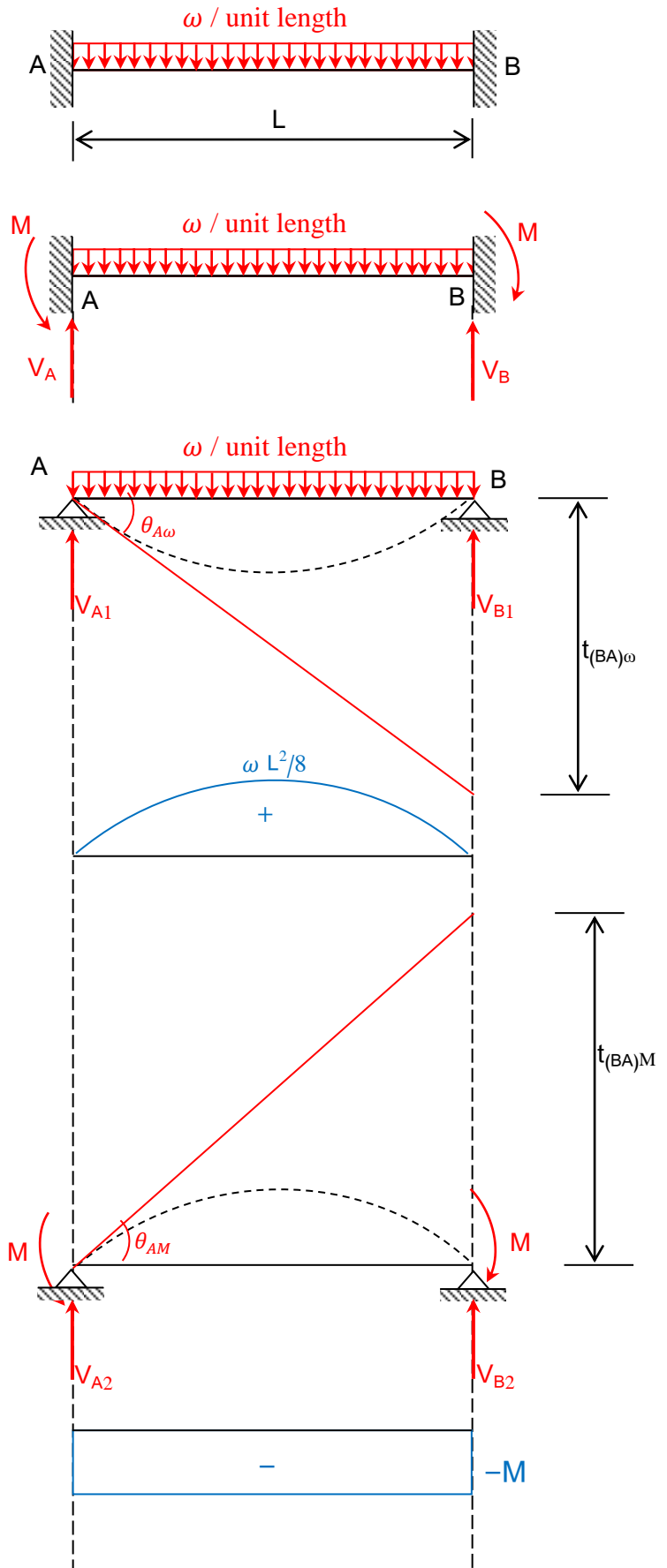

Example (3): Determine the reaction components and draw the shear force and bending moment diagrams for the beam shown in figure. [$EI = \text{Constant}$]

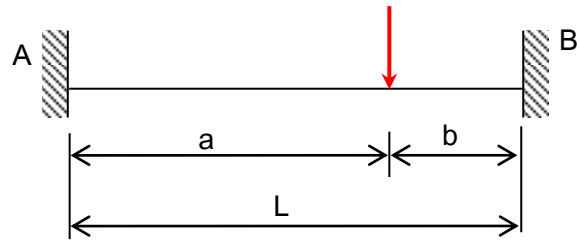

Solution

The beam is statically indeterminate to the second degree.

Using Singularity Functions;

The moment at section x is;

$$M = V_A \cdot x - M_A - P \langle x-a \rangle$$

$$EI \frac{d^2y}{dx^2} = V_A \cdot x - M_A - P \langle x-a \rangle$$

$$EI \frac{dy}{dx} = \frac{V_A \cdot x^2}{2} - M_A \cdot x - \frac{P}{2} \langle x-a \rangle^2 + C_1 \quad \text{-----(1)}$$

$$EI y = \frac{V_A \cdot x^3}{6} - M_A \cdot \frac{x^2}{2} - \frac{P}{6} \langle x-a \rangle^3 + C_1 \cdot x + C_2 \quad \text{----- (2)}$$

$$\left(EI \frac{dy}{dx} \right)_{x=0} = 0 \Rightarrow C_1 = 0$$

$$(EI y)_{x=0} = 0 \Rightarrow C_2 = 0$$

$$EI \frac{dy}{dx} = \frac{V_A \cdot x^2}{2} - M_A \cdot x - P \langle x-a \rangle^2 + C_1$$

$$\left(EI \frac{dy}{dx} \right)_{x=L} = \frac{V_A \cdot L^2}{2} - M_A \cdot L - \frac{P}{2} \langle L-a \rangle^2 = 0$$

$$\frac{V_A \cdot L^2}{2} - M_A \cdot L - \frac{Pb^2}{2} = 0 \quad \text{----- (3)}$$

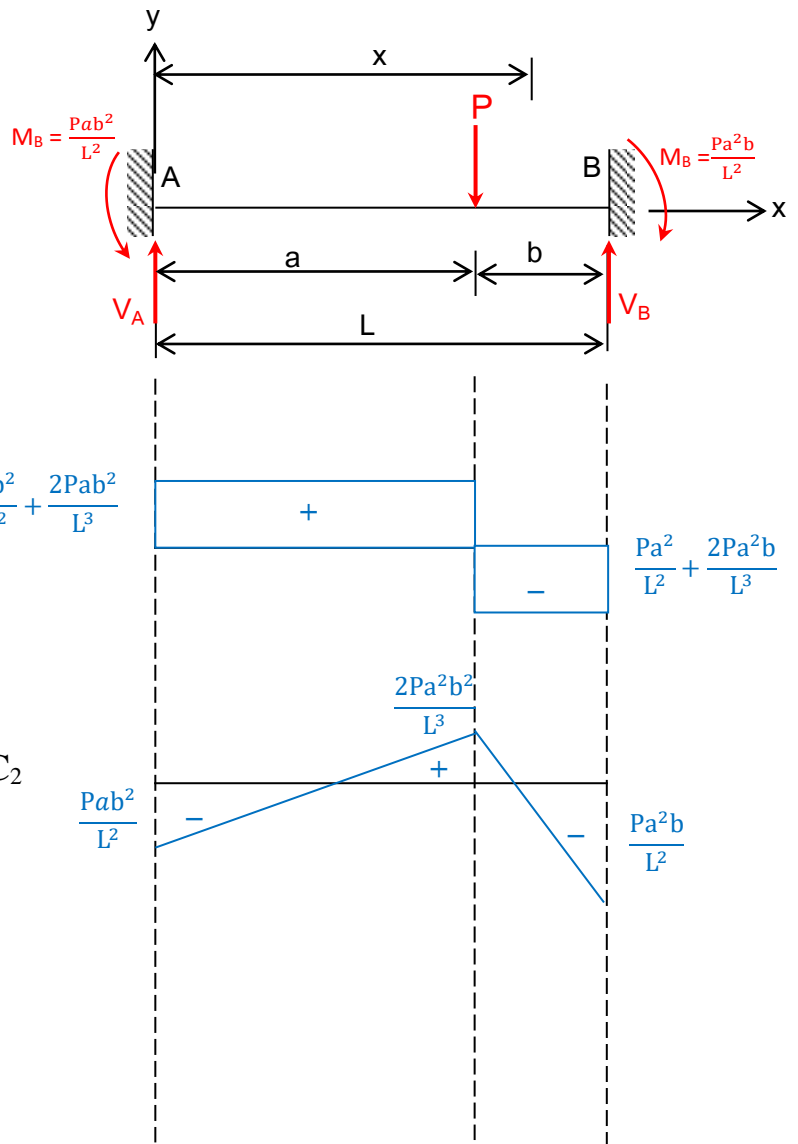

$$(EIy)_{x=L} = \frac{V_A \cdot L^3}{6} - \frac{M_A L^2}{2} - \frac{P}{6} \langle L-a \rangle^3 = 0$$

$$\frac{V_A \cdot L^3}{6} - \frac{M_A L^2}{2} - \frac{Pb^2}{6} = 0 \quad \text{----- (4)}$$

Solving;

$$M_A = \frac{Pab^2}{L^2}$$

$$V_A = \frac{Pb^2}{L^2} + \frac{2Pab^2}{L^3}$$

From equilibrium;

$$M_B = \frac{Pa^2b}{L^2}$$

$$V_B = \frac{Pa^2}{L^2} + \frac{2Pa^2b}{L^3}$$

For $a = b = L/2$, i.e. load is at mid-span;

$$M_A = M_B = \frac{PL}{8}$$

$$V_A = V_B = \frac{P}{2}$$

Example (4): Determine the reactions and draw the shear force and bending moment diagrams for the beam shown in figure by the method of consistent deformations. [$E = 70 \text{ GPa}$, $I = 1250 \times 10^6 \text{ mm}^4$]

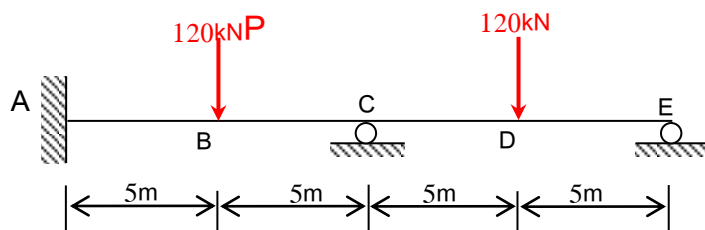

Solution

The beam is statically indeterminate to the second degree. Accordingly we need two compatibility equations.

If the primary determinate beam is selected as the cantilever beam, fixed at A and free at E with two concentrated loads. The redundant are V_C and V_E at supports C and E respectively.

Theory of Structures

The two compatibility equations are;

$$(t_{CA})_{P1} + (t_{CA})_{P2} + (t_{CA})_{VC} + (t_{CA})_{VE} = 0 \quad \text{----- (1)}$$

$$(t_{EA})_{P1} + (t_{EA})_{P2} + (t_{EA})_{VC} + (t_{EA})_{VE} = 0 \quad \text{----- (2)}$$

$$(t_{CA})_{P1} = \frac{-1}{EI} \left[\left(\frac{1}{2} \times 600 \times 5 \right) \left(\frac{2}{3} \times 5 + 5 \right) \right]$$

$$= \frac{-12500}{EI}$$

$$(t_{CA})_{P2} = \frac{-1}{EI} \left[(600 \times 10 \times 5) + \left(\frac{1}{2} \times 1200 \times 10 \right) \left(\frac{2}{3} \times 10 \right) \right]$$

$$= \frac{-70000}{EI}$$

$$(t_{CA})_{VC} = \frac{1}{EI} \left[\left(\frac{1}{2} \times 10V_C \times 10 \right) \left(\frac{2}{3} \times 10 \right) \right]$$

$$= \frac{333.33V_C}{EI}$$

$$(t_{CA})_{VE} = \frac{1}{EI} \left[(10V_E \times 10 \times 5) + \left(\frac{1}{2} \times 10V_E \times 10 \right) \left(\frac{2}{3} \times 10 \right) \right]$$

$$= \frac{833.33V_E}{EI}$$

Substituting in Eq. (1);

$$833.33V_E + 333.33V_C = 82500 \quad \text{----- (3)}$$

$$(t_{EA})_{P1} = \frac{-1}{EI} \left[\left(\frac{1}{2} \times 600 \times 5 \right) \left(\frac{2}{3} \times 5 + 15 \right) \right]$$

$$= \frac{-27500}{EI}$$

$$(t_{EA})_{P2} = \frac{-1}{EI} \left[\left(\frac{1}{2} \times 1800 \times 15 \right) \left(\frac{2}{3} \times 15 + 5 \right) \right] = \frac{-202500}{EI}$$

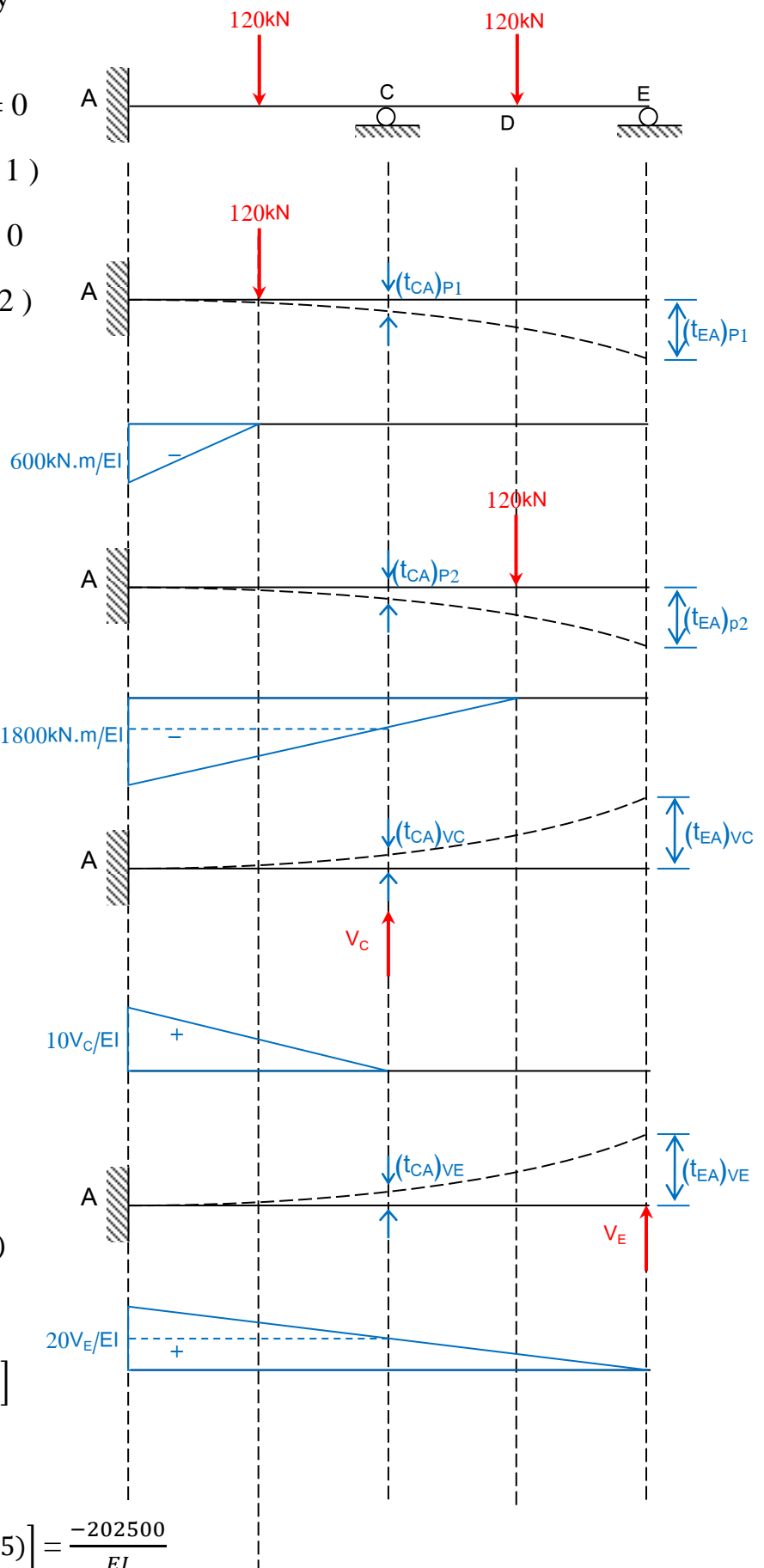

Theory of Structures

$$(t_{EA})_{VC} = \frac{1}{EI} \left[\left(\frac{1}{2} \times 10V_C \times 10 \right) \left(\frac{2}{3} \times 10 + 10 \right) \right] = \frac{833.33V_C}{EI}$$

$$(t_{EA})_{VE} = \frac{1}{EI} \left[\left(\frac{1}{2} \times 20V_E \times 20 \right) \left(\frac{2}{3} \times 20 \right) \right] = \frac{2666.67V_E}{EI}$$

Substituting in Eq. (2);

$$2666.67V_E + 833.33V_C = 230000 \text{ ----- (4)}$$

Solving, $V_C = 145.72 \text{ kN (} \uparrow \text{)}$

$V_E = 40.72 \text{ kN (} \uparrow \text{)}$

From equilibrium; $\sum F_V = 0 \Rightarrow V_A = 53.57 \text{ kN (} \uparrow \text{)}$

$$\sum M_A = 0 \Rightarrow M_A = 128.58 \text{ kN (} \curvearrowright \text{)}$$

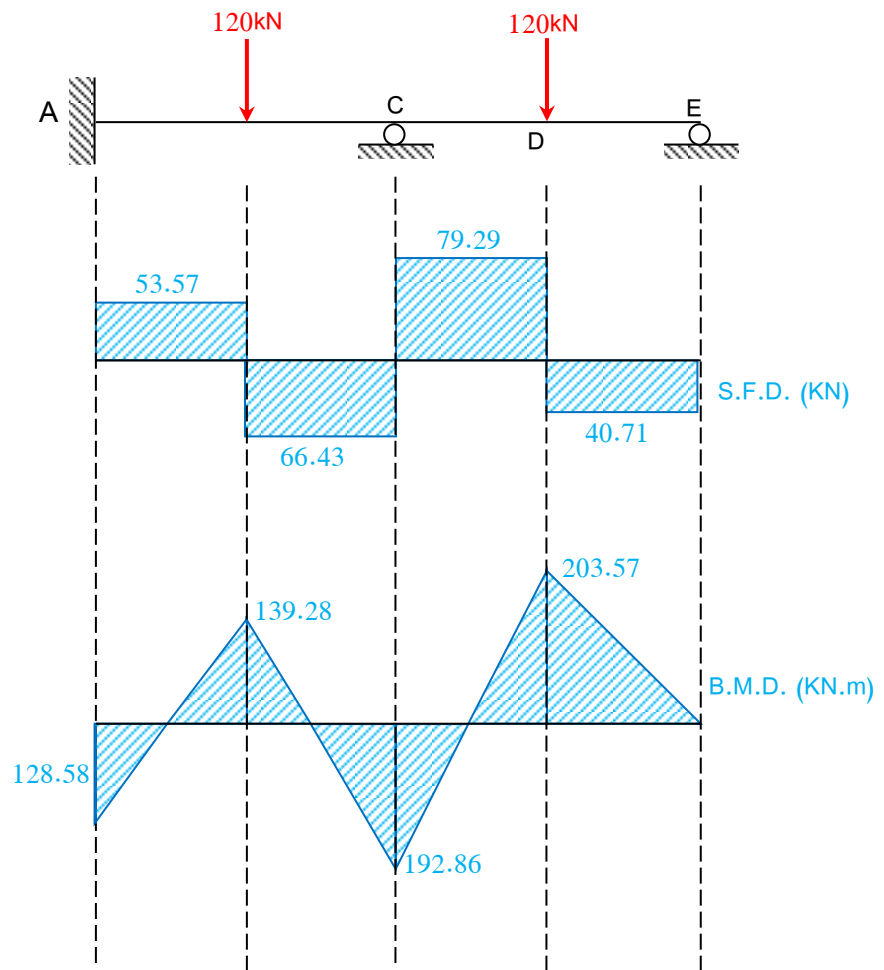

Chapter Eight

Displacement (Equilibrium) Methods

In the previous chapter the governing equations were obtained by the enforcing compatibility at discrete points on the structure.

For displacement (equilibrium) methods, the conditions of equilibrium are explicitly enforced to give solutions for beams and rigid frames that are statically indeterminate.

In this approach the Force-displacement relations, equilibrium, and boundary conditions are imposed on individual beam members, and the equilibrium conditions are enforced at points of connectivity. This results in a set of equations with the displacements as the unknowns and the stiffness quantities as the coefficients.

To displacement (equilibrium) methods suitable for hand calculations are; " The slope-deflection method " and " The moment-distribution method ".

Both methods use moment equilibrium at discrete points to yield the governing equations. The first method gives a set of simultaneous linear algebraic equations that must be solved explicitly, whereas the second poises an iterative solution procedure.

The Slope-Deflection Method

In the slope-deflection method, equilibrium is used to formulate the governing equations for structures composed of flexural members.

The resulting set of simultaneous equations is cast with the angles of rotation and displacements at discrete points as the unknowns and the stiffness quantities as the coefficients. For structures with relatively few unknowns the method is useful and it can also be used to explain the moment-distribution method.

Derivation of the Slope-Deflection Equations

Consider loaded flexural member, and its corresponding bending moment diagram shown in figure below.

The moments at the ends are prescribed using the two subscripts. Together they describe the member; the first indicates the end at which the moment is acting, e.g. M_{ab} is the moment at end " a " of the member ab.

The sign convention is as follows;

- 1- Clockwise rotations (θ) as positive.
- 2- Clockwise member end moments (M) as positive.

The loading on the beam is considered to be the superposition of two load cases. The first load case, consisting of only the applied transverse loads has the moment diagram shown, with " A " denoting the area under the moment diagram and \bar{x} and \bar{x}' the distances from points a and b, respectively, to the centroid of the area.

Using the moment-area theorem, the angles of rotation for this case are given as;

$$\theta_{a1} = \frac{A\bar{x}'}{EIL} \quad , \quad \theta_{b1} = \frac{-A\bar{x}}{EIL} \quad \text{----- (1)}$$

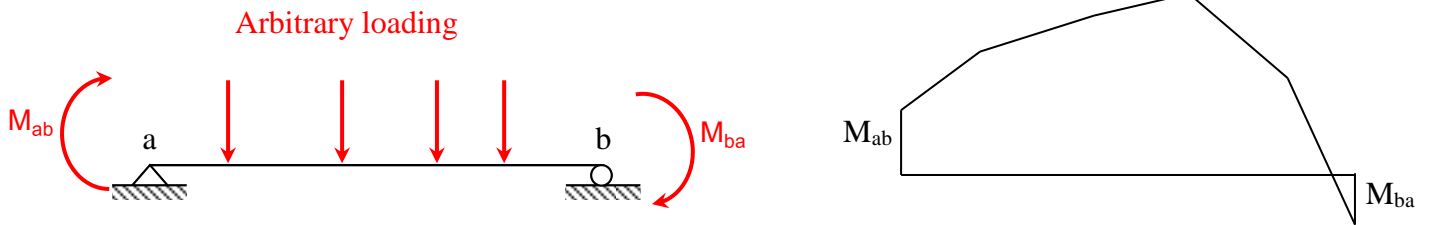

Fig. 1

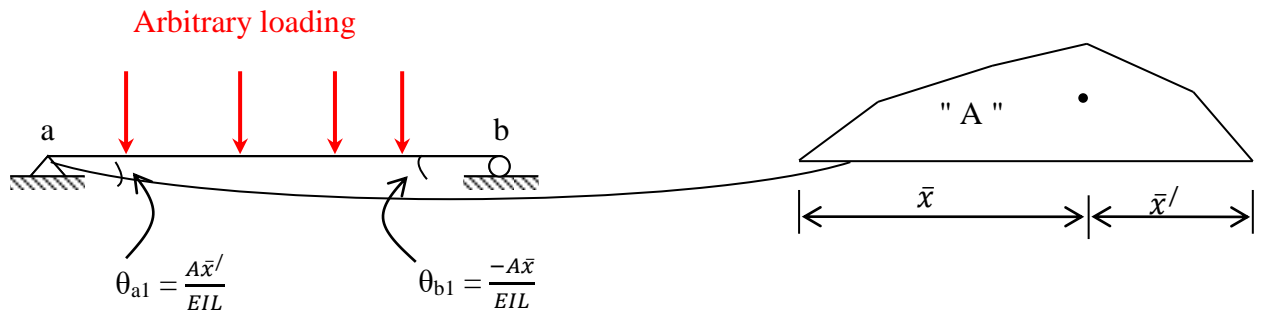

Fig. 2

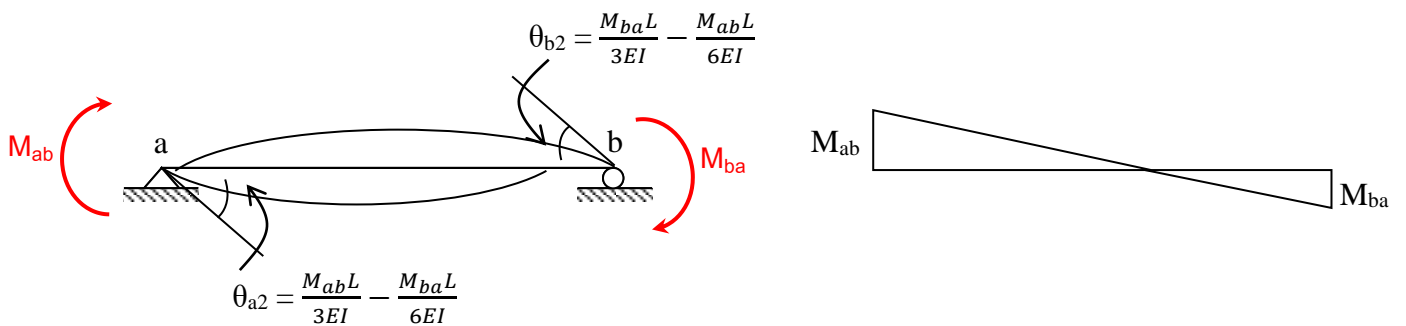

Fig. 3

The moments applied at the ends of the member are the only loads imposed on the beam in the second case, they give the moment diagrams in Fig. (2)

The angles of rotation are;

$$\theta_{a2} = \frac{M_{ab}L}{3EI} - \frac{M_{ba}L}{6EI}$$

$$\theta_{b2} = \frac{M_{ba}L}{3EI} - \frac{M_{ab}L}{6EI} \quad \text{-----} \quad (2)$$

From superposition of the two load cases, the angles of rotation are;

$$\theta_a = \frac{M_{ab}L}{3EI} - \frac{M_{ba}L}{6EI} + \frac{A\bar{x}'}{EIL}$$

$$\theta_b = \frac{M_{ba}L}{3EI} - \frac{M_{ab}L}{6EI} - \frac{A\bar{x}}{EIL} \quad \text{-----} \quad (3)$$

Solving Eq. (3) for the moments gives;

$$M_{ab} = \frac{2EI}{L} (2\theta_a + \theta_b) + \frac{2A}{L^2} (\bar{x} + 2\bar{x}')$$

$$M_{ba} = \frac{2EI}{L} (2\theta_b + \theta_a) + \frac{2A}{L^2} (2\bar{x} + \bar{x}') \quad \text{-----} \quad (4)$$

The terms with $\frac{2A}{L^2}$ in the above equations represents the effect of the applied loads.

They must be computed for each individual loading. If $\theta_a = \theta_b = 0$, the member corresponds to fixed-end beam, and the load terms are the only effects contributing to the end moments. Thus these two terms are the " Fixed-end moment ", and are denoted as;

$$FEM_{ab} = \frac{2A}{L^2} (\bar{x} + 2\bar{x}')$$

$$FEM_{ba} = \frac{2A}{L^2} (2\bar{x} + \bar{x}') \quad \text{-----} \quad (5)$$

Substituting Eq. (5) into Eq. (4), gives;

$$M_{ab} = \frac{2EI}{L} (2\theta_a + \theta_b) + FEM_{ab}$$

$$M_{ba} = \frac{2EI}{L} (2\theta_b + \theta_a) + FEM_{ba} \quad \text{-----} \quad (6)$$

Equations (6) are the slope-deflection equations which express the end moments in terms of the rotations and the applied loading.

They can be written in a convenient form by adopting a near end " a " and far end " f ", hence

$$M_{nf} = 2EK(2\theta_n + \theta_f) + FEM_{nf} \text{ ----- (7)}$$

Where $K = \frac{I}{L}$ is the " Stiffness factor " .

Application of the Slope-Deflection Method to the Analysis of Statically Indeterminate Beams

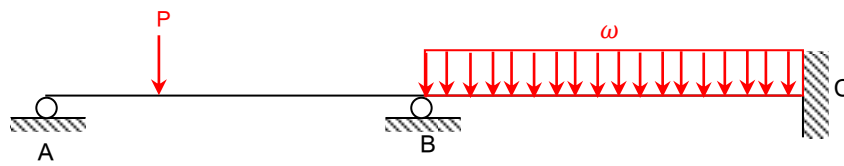

The procedure of the analysing statically indeterminate beams by the slope-deflection method is as follows;

- 1- Determine the fixed-end moments at the ends of each span, using the formula;

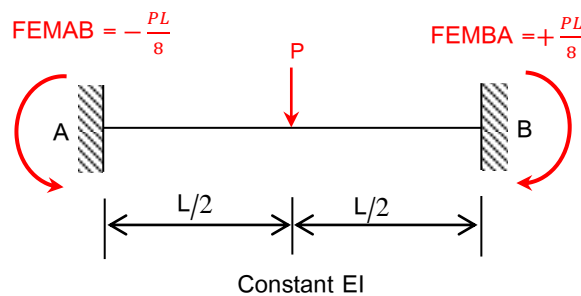
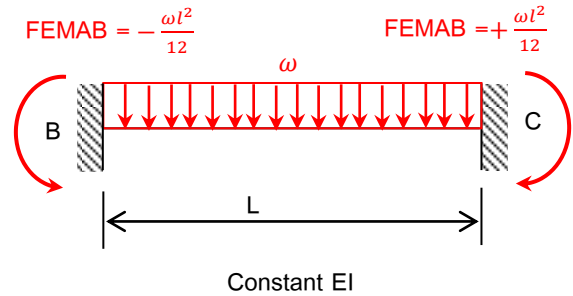
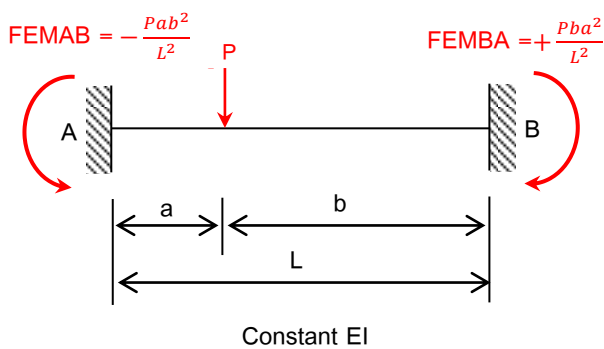

- 2- Express all end moments in terms of the fixed-end moments and the joint rotations by using the slope-deflection equations.

- 3- Establish simultaneous equations with the rotations at the supports as unknowns by applying conditions that the sum of the end moments acting on the ends of the two members meeting at the support should be zero.
- 4- Solve for all the rotations at all supports.
- 5- Substitute the rotations back into the slope-deflection equations, and compute the end moments.

Example (1): Analyse the continuous beam shown in the figure using the slope-deflection method. Draw the bending moment diagram.

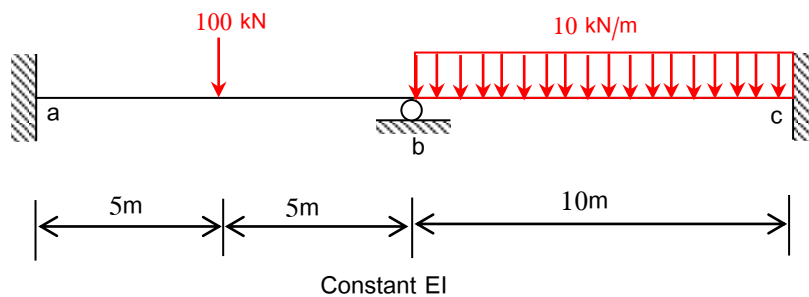

Solution

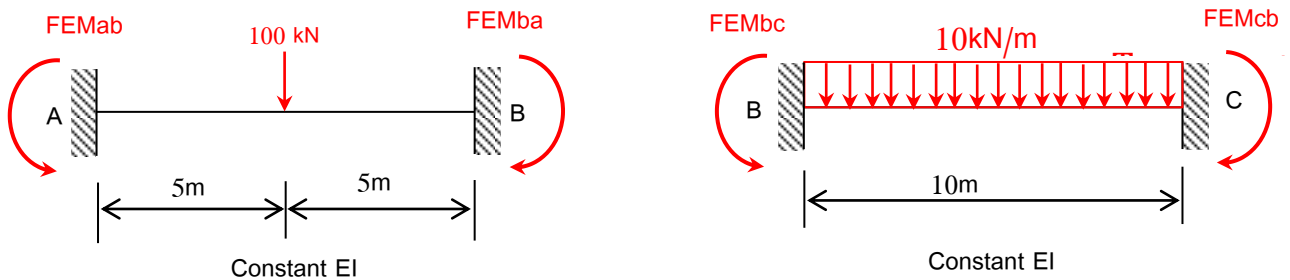

$$FEM_{ab} = - \frac{PL}{8} = - \frac{100 \times 10}{8} = - 125 \text{ kN.m}$$

$$FEM_{ba} = + \frac{PL}{8} = + \frac{100 \times 10}{8} = + 125 \text{ kN.m}$$

$$FEM_{bc} = - \frac{\omega L^2}{12} = - \frac{10 \times 10^2}{12} = - 83.33 \text{ kN.m}$$

$$FEM_{cb} = + \frac{\omega L^2}{12} = + \frac{10 \times 10^2}{12} = + 83.33 \text{ kN.m}$$

For span ab;

$$M_{ab} = \frac{2EI}{10} (2\theta_a + \theta_b) - 125 = \frac{2EI}{10} (\theta_b) - 125$$

$$M_{ba} = \frac{2EI}{10} (2\theta_b + \theta_a) + 125 = \frac{2EI}{10} (2\theta_b) + 125$$

For span bc;

$$M_{bc} = \frac{2EI}{10} (2\theta_b + \theta_c) - 83.33 = \frac{2EI}{10} (2\theta_b) - 83.33$$

$$M_{cb} = \frac{2EI}{10} (2\theta_c + \theta_b) + 83.33 = \frac{2EI}{10} (\theta_b) + 83.33$$

From equilibrium at joint " b " ;

$$M_{ba} + M_{bc} = 0$$

$$\frac{2EI}{10} (2\theta_b) + 125 + \frac{2EI}{10} (2\theta_b) - 83.33 = 0$$

$$\frac{8EI}{10} (\theta_b) + 44.67 = 0$$

$$\theta_b = - \frac{52.09}{EI}$$

Substituting;

$$M_{ab} = \frac{2}{10} (- 52.09) - 125 = -135.42 \text{ kN.m}$$

$$M_{ba} = \frac{4}{10} (- 52.09) + 125 = +104.16 \text{ kN.m}$$

$$M_{bc} = \frac{4}{10} (- 52.09) - 83.33 = -104.16 \text{ kN.m}$$

$$M_{cb} = \frac{2}{10} (- 52.09) + 83.33 = +72.91 \text{ kN.m}$$

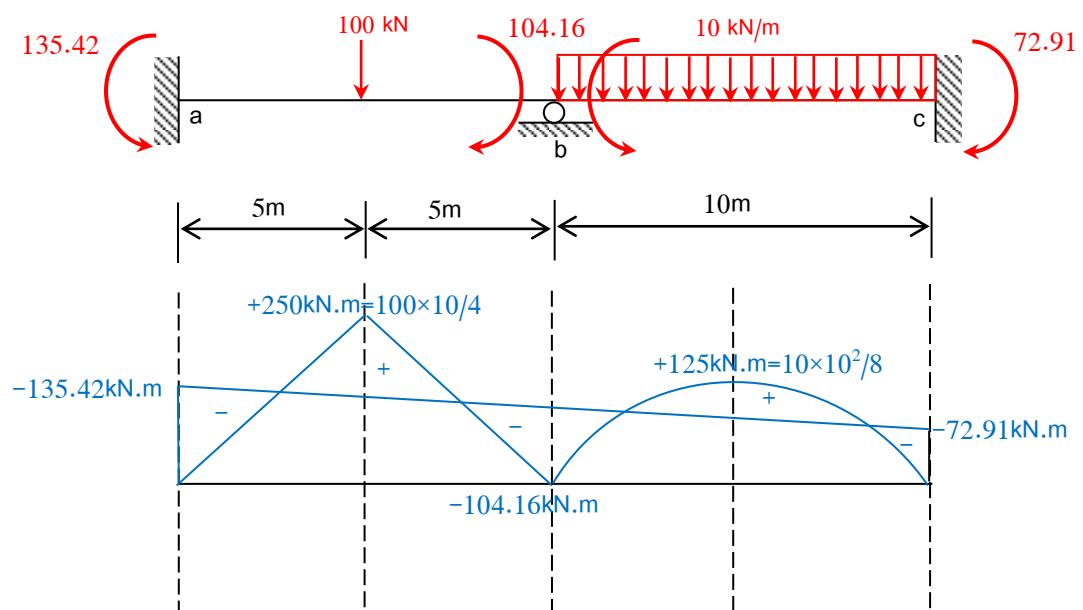

Analysis of Rigid Frames without Joint Translation

In some types of frames, the joints are not free to translate, such as Figs. (a) and (b), whereas in Figs. (c) and (d), the joints are free to move but don't due to symmetry of the frame and loads about an axis. For each cases the equations (6) can be applied directly for analysis.

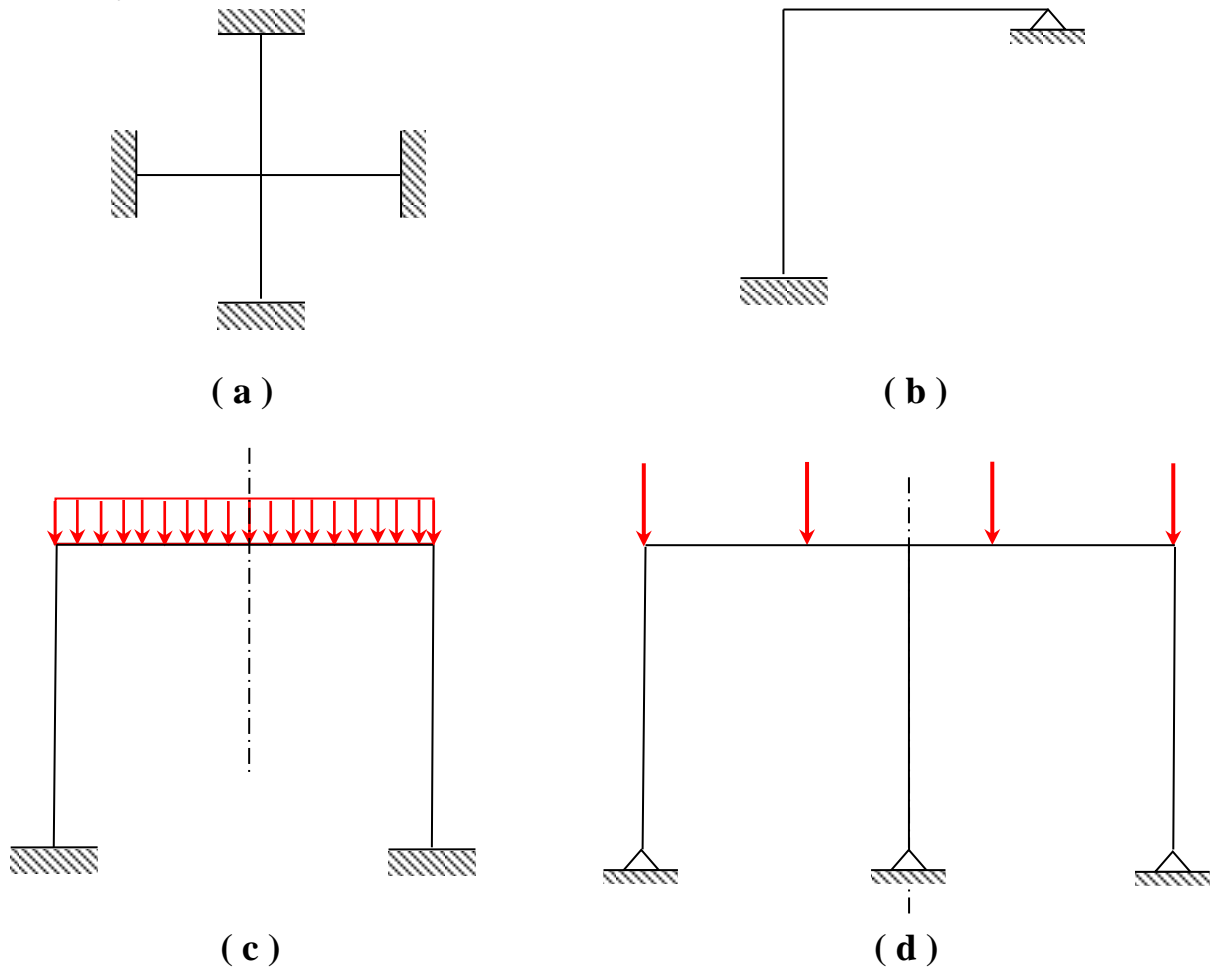

Example (2): The frame shown in the figure is fixed at " A " and hinged at " C " and " D ". Analyse the frame using the slope-deflection method and draw the shear force and bending moment diagrams.

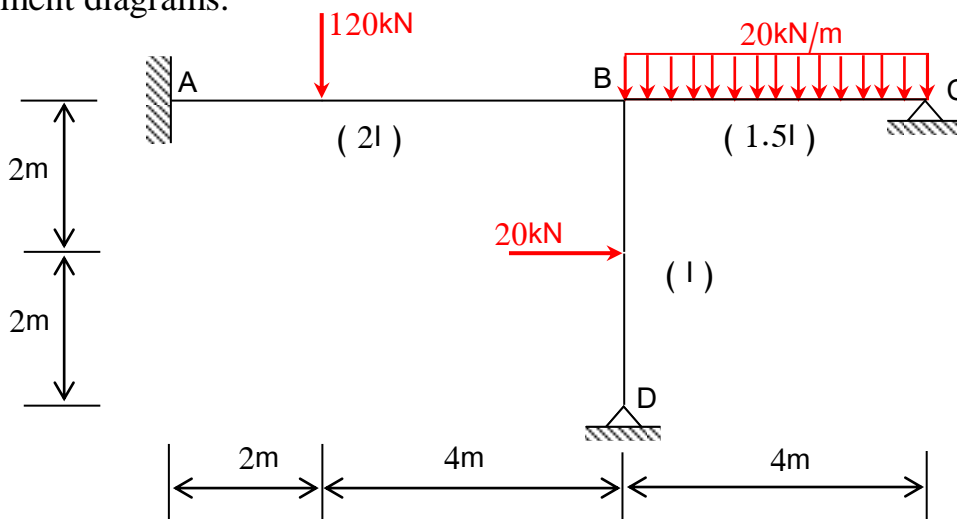

Solution

$$FEM_{AB} = - \frac{Pab^2}{L^2} = - \frac{120 \times 2 \times 4^2}{6^2} = - 106.67 \text{ kN.m}$$

$$FEM_{BA} = + \frac{Pba^2}{L^2} = + \frac{120 \times 4 \times 2^2}{6^2} = + 53.33 \text{ kN.m}$$

$$FEM_{BC} = - \frac{\omega L^2}{12} = - \frac{20 \times 4^2}{12} = - 26.67 \text{ kN.m}$$

$$FEM_{CB} = + \frac{\omega L^2}{12} = + \frac{20 \times 4^2}{12} = + 26.67 \text{ kN.m}$$

$$FEM_{BD} = + \frac{PL}{8} = + \frac{20 \times 4}{8} = + 10 \text{ kN.m}$$

$$FEM_{DB} = - \frac{PL}{8} = - \frac{20 \times 4}{8} = - 10 \text{ kN.m}$$

In this problem $\theta_A = 0$;

The slope-deflection equations are;

$$M_{AB} = \frac{2EI_{AB}}{L_{AB}} (2\theta_A + \theta_B) - FEM_{AB} = \frac{2(2EI)}{6} (\theta_B) - 106.67$$

$$M_{BA} = \frac{2EI_{AB}}{L_{AB}} (2\theta_B + \theta_A) - FEM_{BA} = \frac{2(2EI)}{6} (2\theta_B) + 53.33$$

$$M_{BC} = \frac{2EI_{BC}}{L_{BC}} (2\theta_B + \theta_C) - FEM_{BC} = \frac{2(1.5EI)}{4} (2\theta_B + \theta_C) - 26.67$$

$$M_{CB} = \frac{2EI_{BC}}{L_{BC}} (2\theta_C + \theta_B) - FEM_{CB} = \frac{2(1.5EI)}{4} (2\theta_C + \theta_B) + 26.67$$

$$M_{BD} = \frac{2EI_{BD}}{L_{BD}} (2\theta_B + \theta_D) + FEM_{BD} = \frac{2(EI)}{4} (2\theta_B + \theta_D) + 10$$

$$M_{DB} = \frac{2EI_{BD}}{L_{BD}} (2\theta_D + \theta_B) + FEM_{DB} = \frac{2(EI)}{4} (2\theta_D + \theta_B) - 10$$

In the above equations, there are three unknown rotations θ_B , θ_C , θ_D , and from equilibrium;

$$M_{BA} + M_{BC} + M_{BD} = 0 \quad \text{----- (1)}$$

$$M_{CB} = 0 \quad \text{----- (2)}$$

$$M_{DB} = 0 \quad \text{----- (3)}$$

From Eq. (1);

$$\frac{2(2EI)}{6} (2\theta_B) + 53.33 + \frac{2(1.5EI)}{4} (2\theta_B + \theta_C) - 26.67 + \frac{2(EI)}{4} (2\theta_B + \theta_D) + 10 = 0$$

$$36.66 + \frac{23}{6} EI \theta_B + \frac{3}{4} EI \theta_C + \frac{1}{2} EI \theta_D = 0 \quad \text{----- (4)}$$

From Eq. (2);

$$M_{CB} = \frac{2(1.5EI)}{4} (2\theta_C + \theta_B) + 26.67 = 26.67 + \frac{3}{4} EI \theta_B + \frac{3}{2} EI \theta_C = 0 \quad \text{----- (5)}$$

From Eq. (3);

$$M_{DB} = \frac{2(EI)}{4} (2\theta_D + \theta_B) - 10 = -10 + \frac{1}{2} EI \theta_B + EI \theta_D = 0 \quad \text{----- (6)}$$

Solving Eqs. (4) , (5), and (6);

$$EI \theta_B = - 8.83$$

$$EI \theta_C = - 13.36$$

$$EI \theta_D = + 14.42$$

Substituting in the slope-deflection equations;

$$M_{AB} = - 112.56 \text{ kN.m}$$

$$M_{BA} = + 41.56 \text{ kN.m}$$

$$M_{BC} = - 49.94 \text{ kN.m}$$

$$M_{CB} = 0 \text{ kN.m}$$

$$M_{BD} = + 8.38 \text{ kN.m}$$

$$M_{DB} = 0 \text{ kN.m}$$

Span AB;

$$\sum M_A = 0 \Rightarrow V_{B1} (6) - 41.56 - 120 (2) + 112.56 = 0$$

$$V_{B1} = 28.17 \text{ kN}$$

$$\sum V_y = 0 \Rightarrow V_A + 28.17 - 120 = 0$$

$$V_A = 91.8 \text{ kN}$$

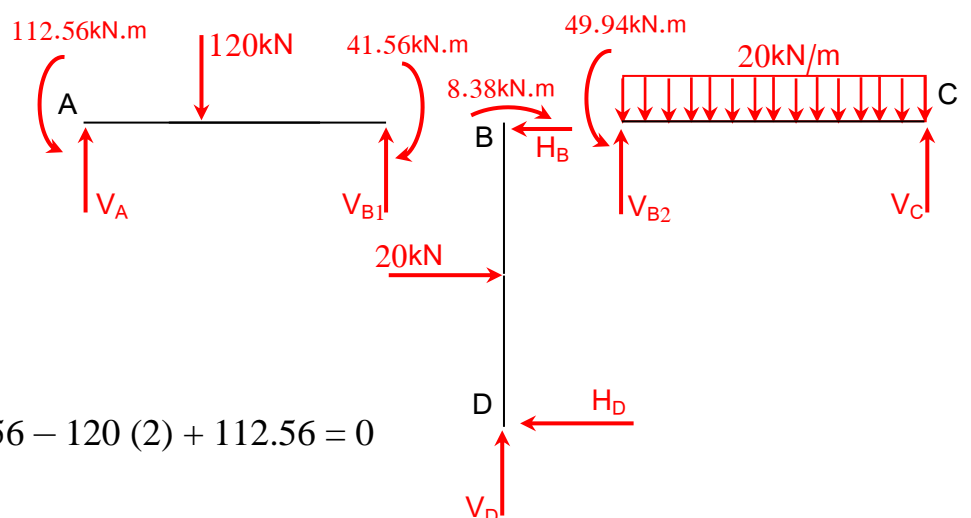

Theory of Structures

Span BC;

$$\sum M_B = 0 \Rightarrow V_C (4) - 20 (4)(2) + 49.94 = 0$$

$$V_C = 27.52 \text{ kN}$$

$$\sum V_y = 0 \Rightarrow V_{B2} - 20 (4) + 27.52 = 0$$

$$V_{B2} = 52.48$$

Column BD;

$$\sum M_B = 0 \Rightarrow H_D (4) - 20 (2) + 8.38 = 0$$

$$H_D = 7.91 \text{ kN}$$

$$H_B = 12.09 \text{ kN}$$

For the whole frame;

$$\sum V = 0 \Rightarrow V_D \text{ will be found}$$

$$\sum H = 0 \text{ and } \sum M_D = 0 \Rightarrow H_A \text{ \& } H_C \text{ will be found}$$

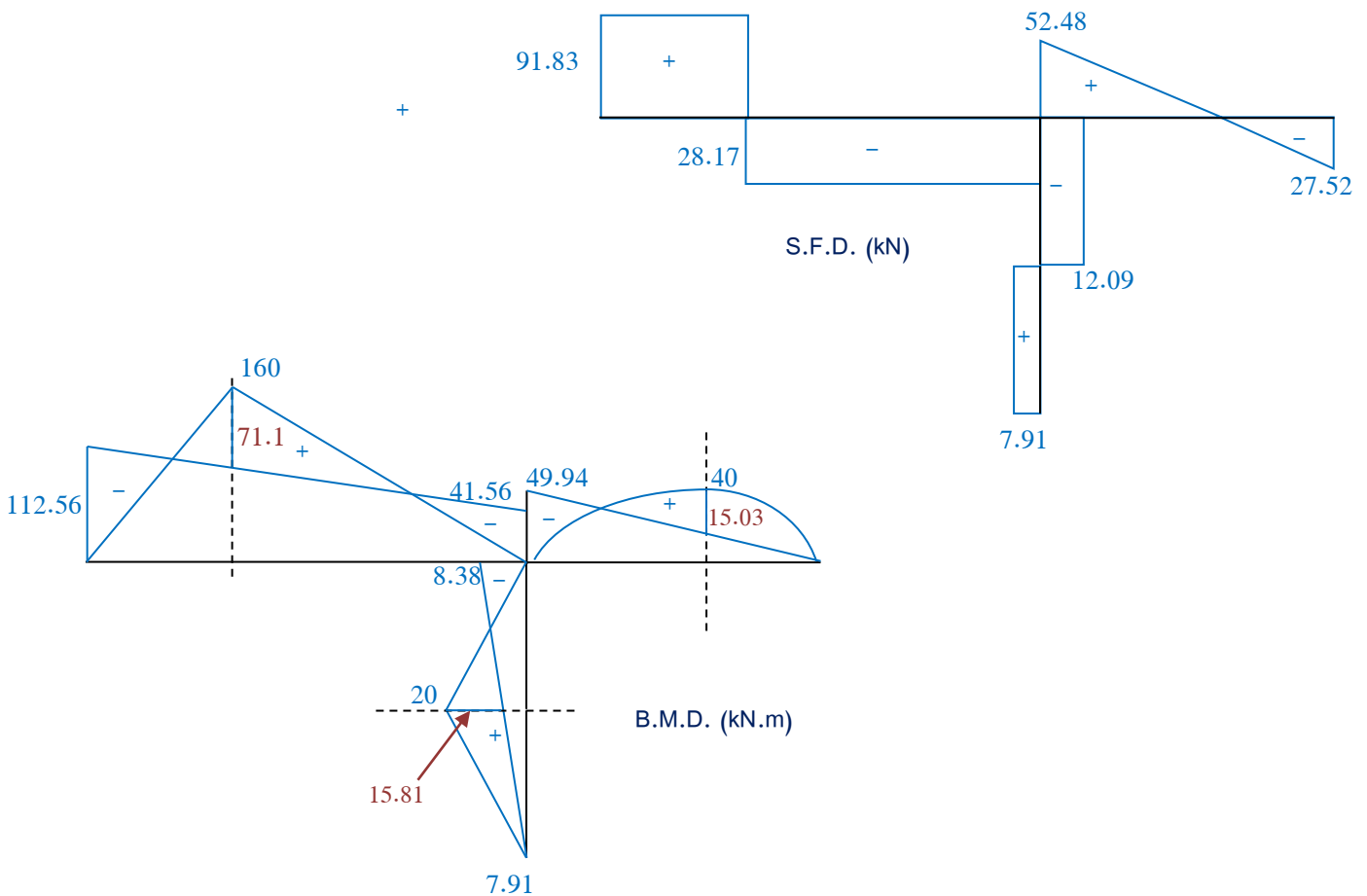

The Moment-Distribution Method

General Description of the Moment-Distribution Method

The moment-distribution method can be used to analyse all types of statically indeterminate beams or rigid frames. Essentially it consists of solving the simultaneous equations in the slope-deflection method by successive approximations.

Consider the following problem:

If a clockwise moment M_A is applied at the simple support of a straight member of constant cross-section simply supported at one end and fixed at the other, find the rotation θ_A at the simple support and the moment M_B at the fixed end.

The method of consistent deformation will be used. The condition of the geometry required is:

$$\theta_{B1} + \theta_{B2} = \theta_B = 0$$

From the second moment-area theorem ;

$$(t_{AB})_1 = \frac{1}{EI} \left(\frac{1}{2} M_A \cdot L \right) \left(\frac{L}{3} \right) = \frac{M_A L^2}{6EI}$$

$$\theta_{B1} = \frac{(t_{AB})_1}{L} = \frac{M_A L}{6EI}$$

$$(t_{AB})_2 = \frac{1}{EI} \left(\frac{-1}{2} M_B \cdot L \right) \left(\frac{2L}{3} \right) = \frac{-M_B L^2}{3EI}$$

$$\theta_{B2} = \frac{(t_{AB})_2}{L} = \frac{-M_B L}{3EI}$$

$$\text{hence; } \frac{M_A L}{6EI} - \frac{M_B L}{3EI} = 0$$

$$M_B = \frac{1}{2} M_A$$

Also, $\theta_A = \theta_{A1} + \theta_{A2}$

$$\theta_{A1} = \frac{(t_{BA})_1}{L}$$

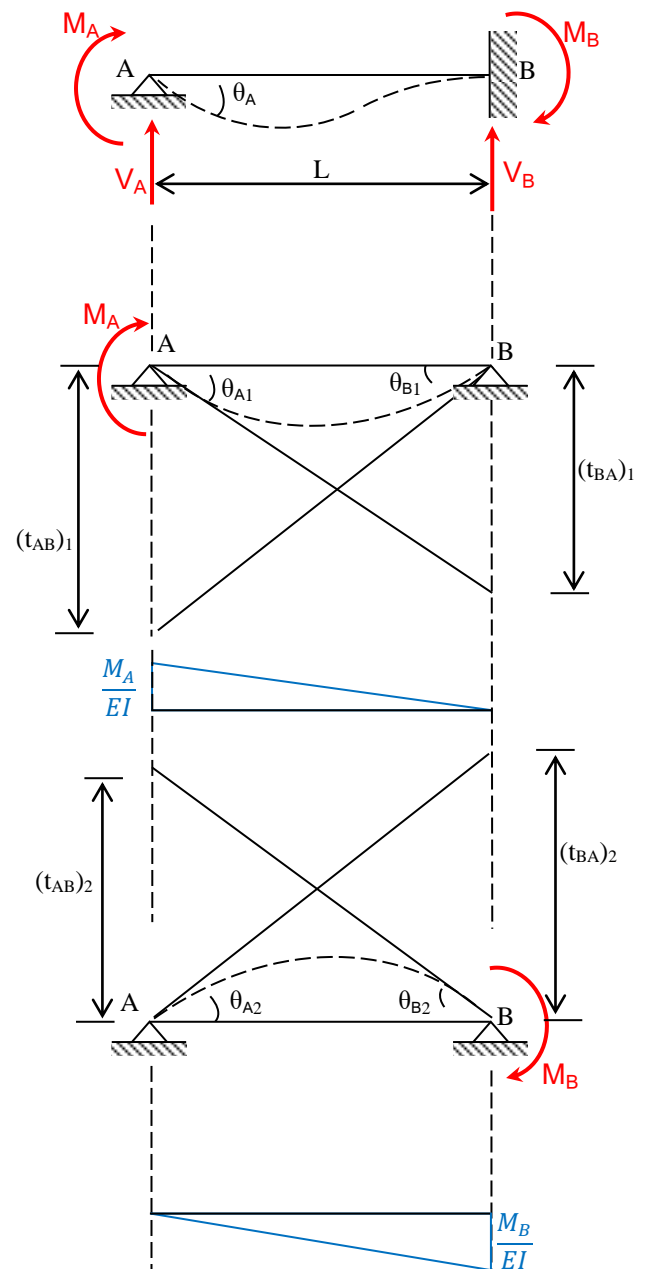

$$(t_{BA})_1 = \frac{1}{EI} \left(\frac{1}{2} M_A \cdot L \right) \left(\frac{2L}{3} \right) = \frac{M_A L^2}{3EI}$$

$$\theta_{A1} = \frac{M_A L}{3EI}$$

$$\theta_{A2} = \frac{(t_{BA})_2}{L}$$

$$(t_{BA})_2 = \frac{1}{EI} \left(\frac{-1}{2} M_B \cdot L \right) \left(\frac{L}{3} \right) = \frac{-M_B L^2}{6EI}$$

$$\theta_{B2} = \frac{-M_B L}{6EI}$$

$$\theta_A = \frac{M_A L}{3EI} - \frac{M_B L}{6EI} = \frac{M_A L}{3EI} - \frac{(\frac{1}{2} M_A) L}{6EI} = \frac{M_A L}{3EI} - \frac{M_A L}{12EI}$$

$$\theta_A = M_A \cdot \frac{L}{4EI}$$

$$M_A = \frac{4EI}{L} \cdot \theta_A$$

Thus, for a span AB which is simply supported at A and fixed at B, a clockwise rotation of θ_A can be effected by applying a clockwise moment of $M_A = \left(\frac{4EI}{L} \right) \cdot \theta_A$ at A, which in turn induces a clockwise of $M_B = \frac{1}{2} M_A$ on the member at B. The expression $\left(\frac{4EI}{L} \right)$ is usually called " Stiffness factor, k ", which is defined as the moment required to be applied at A to cause a rotation of 1 rad at A of a span AB simply supported at A and fixed at B, the number $\left(+ \frac{1}{2} \right)$ is the " carry-over factor, CO ", which is the ratio of the moment induced at B to the moment applied at A.

Note that the same sign convention is used in the moment-distribution method as in the slope-deflection method.

Modified stiffness Factor at the near End of a Member When the Far End is Hinged

It has been shown that the stiffness factor " k " for a member with constant cross-section is given by $(\frac{4EI}{L})$ when the far end is fixed.

If the far end is hinged, the stiffness factor is given by $(\frac{3EI}{L})$ or $(\frac{3}{4})$ of that when the far end is fixed $(\frac{3}{4}k)$. This can be derived by the moment-area method.

$$t_{BA} = \frac{1}{EI} \left(\frac{1}{2} M_A \cdot L \right) \left(\frac{2L}{3} \right) = \frac{M_A L^2}{3EI}$$

$$\theta_A = \frac{t_{BA}}{L} = \frac{M_A L}{3EI}$$

$$M_A = \left(\frac{3EI}{L} \right) \cdot \theta_A = \left(\frac{3}{4} \right) \left(\frac{4EI}{L} \right) \cdot \theta_A$$

$$M_A = \left(\frac{3}{4} \right) k \cdot \theta_A$$

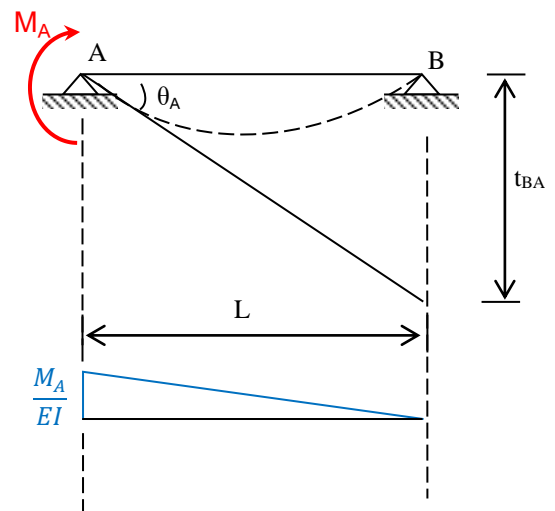

Distribution Factor

Consider the three members AB, DB, and CB rigidly joined at B.

When a moment (M) is applied at (B), the joint will rotate a small angle (θ), and this is the same for all the members at the joint.

The stiffness of each member is given by $k = \frac{M}{\theta}$.

The distributed to each member is M_{BA} , M_{BC} , and M_{BD} .

$$k_{BA} = \frac{M_{BA}}{\theta} \quad , \quad k_{BC} = \frac{M_{BC}}{\theta} \quad , \quad k_{BD} = \frac{M_{BD}}{\theta}$$

At the joint the sum of all the moments is zero,

$$M_{BA} + M_{BC} + M_{BD} = M$$

$$(k_{BA}) \cdot \theta + (k_{BC}) \cdot \theta + (k_{BD}) \cdot \theta = M$$

$$k_{BA} + k_{BC} + k_{BD} = \frac{M}{\theta}$$

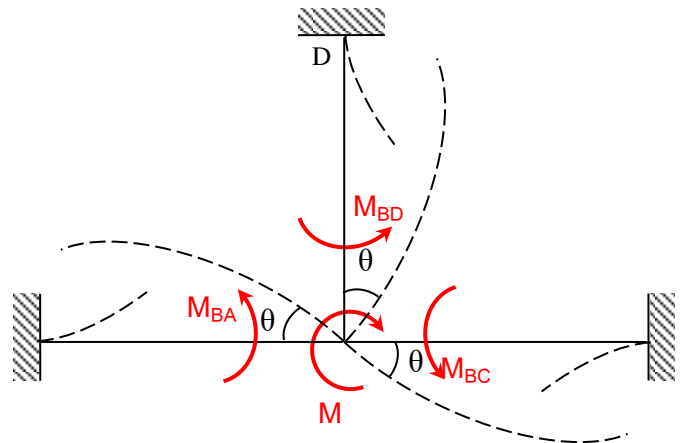

$$\theta = \frac{M}{\sum k}$$

$$M_{BA} = (k_{BA}) \cdot \theta = \frac{k_{BA}}{\sum k} \cdot M$$

$$M_{BC} = (k_{BC}) \cdot \theta = \frac{k_{BC}}{\sum k} \cdot M$$

$$M_{BD} = (k_{BD}) \cdot \theta = \frac{k_{BD}}{\sum k} \cdot M$$

i.e. the moment is distributed to each member by the distribution factor $DF = \frac{k}{\sum k}$.

$$M_{BA} = (DF)_{BA} \cdot M$$

$$M_{BC} = (DF)_{BC} \cdot M$$

$$M_{BD} = (DF)_{BD} \cdot M$$

At the case when the far end is a simply supported as shown, its distribution factor could be computed as below;

$$DF = \frac{k_{CB}}{\sum k} = \frac{k_{CB}}{k_{CB}+0} = 1$$

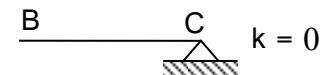

At the case when the far end is a fixed as shown, its distribution factor could be computed as below;

$$DF = \frac{k_{AB}}{\sum k} = \frac{k_{AB}}{k_{AB}+\infty} = 0$$

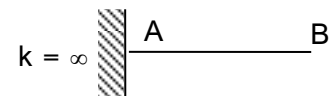

Procedure

The moment-distribution method consists in solving the slope-deflection equations by a system of successive approximations. The procedure is as follows;

- 1- Determine the terminal moments on the assumption that all rotational or translational movements are prevented, i.e. determine the "Fixed-end moments".
- 2- Distribute the unbalanced moments so found at any support to each adjacent span in a definite proportion. These moments are termed "distribution" or "balancing" moments.
- 3- Due to application of a "distribution" or "balancing" moment at one terminal of a beam there is induced a moment at the other terminal. This moment is termed the "carry-over" moment.
- 4- This "carry-over" moment added now gives an out-of-balance condition at a common support and the "out-of-balance" moment is "distributed" or "balanced" as in (2).
- 5- "carry-over" and "distribution" is continued until there is a very small residual unbalanced moment at any support.

Example (1): The beam ABC is loaded as shown in Figure. Analyse the beam using the moment-distribution method, and draw the shear force and bending moment diagrams.

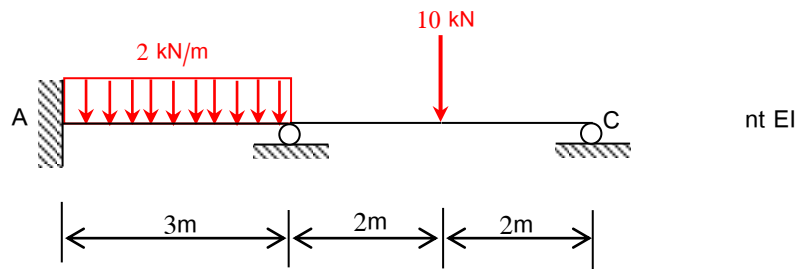

Solution

The fixed-end moments are;

$$FEM_{AB} = -\frac{\omega L^2}{12} = -\frac{2 \times 3^2}{12} = -1.5 \text{ kN.m}$$

$$FEM_{BA} = +\frac{\omega L^2}{12} = +\frac{2 \times 3^2}{12} = +1.5 \text{ kN.m}$$

$$FEM_{BC} = -\frac{PL}{8} = -\frac{10 \times 4}{8} = -5 \text{ kN.m}$$

$$FEM_{CB} = +\frac{PL}{8} = +\frac{10 \times 4}{8} = +5 \text{ kN.m}$$

The stiffness factors for the members are;

$$k_{AB} = \frac{4EI}{L} = \frac{4EI}{3}, \quad k_{BC} = \frac{4EI}{4}$$

The distribution factors are;

$$DF_{AB} = 0$$

$$DF_{BA} = \frac{\left(\frac{4EI}{3}\right)}{\left(\frac{4EI}{3}\right) + \left(\frac{4EI}{4}\right)} = 0.571$$

$$DF_{Bc} = \frac{\left(\frac{4EI}{4}\right)}{\left(\frac{4EI}{3}\right) + \left(\frac{4EI}{4}\right)} = 0.429$$

$$DF_{CB} = 1$$

Joint	A	B		C
Member	AB	BA	BC	CB
DF	0	0.571	0.429	1
FEM	-1.5	+1.5	-5	+5
Dist. Moment	0	+1.998	+1.502	-5
CO	+0.999	0	-2.5	+0.751
Dist. Moment	0	+1.428	+1.072	-0.751
CO	+0.714	0	-0.375	+0.536
Dist. Moment	0	+0.214	+0.161	-0.536
CO	+0.107	0	-0.268	+0.081
Dist. Moment	0	+0.153	+0.115	-0.081
CO	+0.076	0	-0.041	+0.057
Dist. Moment	0	+0.023	+0.018	-0.057
CO	+0.012	0	-0.029	+0.009
Dist. Moment	0	+0.016	+0.013	-0.009
CO	+0.008	0	-0.005	+0.007
Dist. Moment	0	+0.003	+0.002	-0.007
CO	+0.002	0	-0.004	+0.001
Dist. Moment	0	+0.002	+0.002	-0.001
CO	+0.001	0	0.000	+0.001
Dist. Moment	0	0	0	-0.001
End moments	+ 0.419	+5.337	-5.337	0

To determine the reactions;

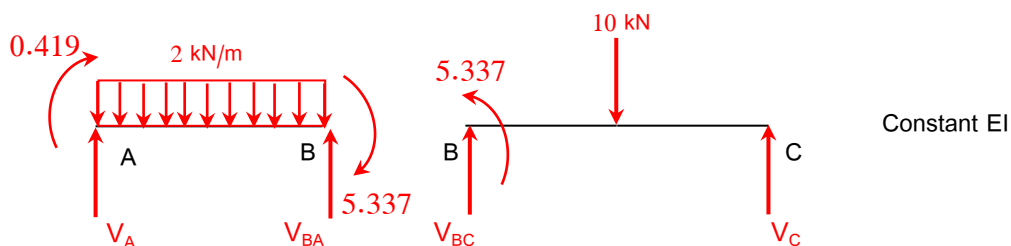

Member AB;

$$\sum M_B = V_A (3) + 0.419 - 2(3)1.5 + 5.337 = 0$$

$$\Rightarrow V_A = 1.081 \text{ kN (}\uparrow\text{)}$$

$$\sum M_A = V_{BA} (3) - 0.419 - 2(3)1.5 - 5.337 = 0$$

$$\Rightarrow V_{BA} = 4.919 \text{ kN (}\uparrow\text{)}$$

Member BC;

$$\sum M_B = V_C (4) - 10(2) + 5.337 = 0$$

$$\Rightarrow V_C = 3.666 \text{ kN (}\uparrow\text{)}$$

$$\sum M_C = V_{BC} (4) - 10(2) - 5.337 = 0$$

$$\Rightarrow V_{BC} = 6.334 \text{ kN (}\uparrow\text{)}$$

$$\text{Hence } V_B = 6.334 + 4.919 = 11.253$$

For check; $1.081 + 3.666 + 11.253 = 2 \times 3 + 10 = 16 \text{ kN}$ OK

Theory of Structures

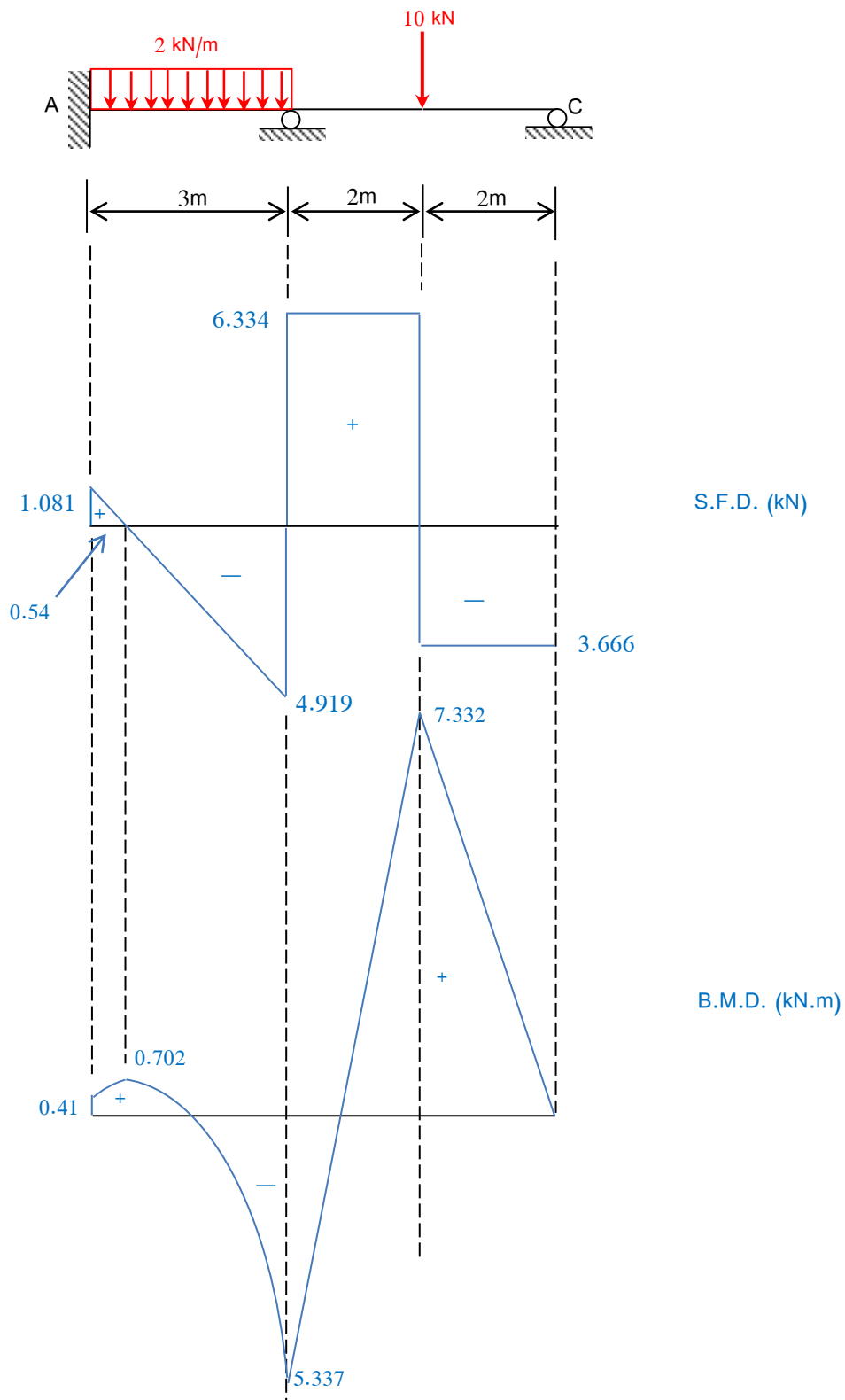

Example (2): Analyse the beam ABC given in Example (1) using modified stiffness factor.

The stiffness factors for the members are;

$$k_{AB} = \frac{4EI}{L} = \frac{4EI}{3} \quad , \quad k_{BC} = \frac{3}{4} \left(\frac{4EI}{4} \right) = \frac{3EI}{4}$$

The distribution factors are;

$$DF_{AB} = 0$$

$$DF_{BA} = \frac{\left(\frac{4EI}{3}\right)}{\left(\frac{4EI}{3}\right) + \left(\frac{3EI}{4}\right)} = 0.64$$

$$DF_{Bc} = \frac{\left(\frac{3EI}{4}\right)}{\left(\frac{4EI}{3}\right) + \left(\frac{3EI}{4}\right)} = 0.36$$

$$DF_{CB} = 1$$

Joint	A	B		C
Member	AB	BA	BC	CB
DF	0	0.64	0.36	1
FEM	-1.5	+1.5	-5	+5
Dist. Moment	0	+2.24	+1.26	-5
CO	+1.12	0	-2.5	0
Dist. Moment	0	+1.6	+0.9	0
CO	+0.8	0	0	0
Dist. Moment	0	0	0	0
End moments	+ 0.42	+5.34	-5.34	0

Joint (C) is balanced only once in the first cycle, and no moments are carried to it.

In general, simple or hinged supports need to be balanced only once, and no carry-over moments are ever brought back to them.

Example (3): The beam ABCD is loaded as shown in the figure. Analyse the beam using the moment-distribution method, and draw the shear and bending moment diagrams.

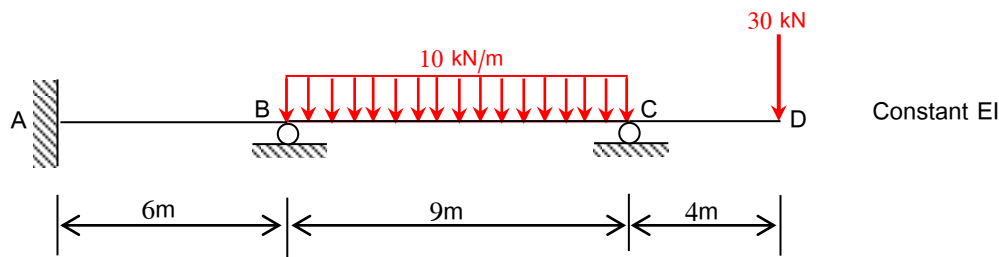

Solution

Notes

- 1- Since we know in advance the final moment at the end of a cantilever, we do not distribute moments into a cantilever. Therefore a cantilever has a distribution factor of zero;

$$DF(\text{cantilever}) = 0$$

This is implemented by considering cantilevers to have zero stiffness, $k = 0$

- 2- We consider the cantilever moment as a fixed end moment applied to the joint and then balance the joint as normal. The adjacent span does not therefore have continuity and takes modified stiffness, $(\frac{3}{4}k)$.

The fixed-end moments are;

$$FEM_{AB} = FEM_{BA} = 0$$

$$FEM_{BC} = -\frac{\omega L^2}{12} = -\frac{10 \times 9^2}{12} = -67.5 \text{ kN.m}$$

$$FEM_{CB} = +\frac{\omega L^2}{12} = +\frac{10 \times 9^2}{12} = +67.5 \text{ kN.m}$$

$$FEM_{CD} = -30 \times 4 = -120 \text{ kN.m}$$

The stiffness factors for the members are;

$$k_{AB} = \frac{4EI}{L} = \frac{4EI}{6} = \frac{2EI}{3}$$

$$k_{BC} = \frac{3EI}{L} = \frac{3EI}{9} = \frac{EI}{3}$$

$$k_{CD} = 0$$

The distribution factors are;

$$DF_{AB} = 0$$

$$DF_{BA} = \frac{\left(\frac{2EI}{3}\right)}{\left(\frac{2EI}{3}\right) + \left(\frac{EI}{3}\right)} = 0.667$$

$$DF_{BC} = \frac{\left(\frac{EI}{3}\right)}{\left(\frac{2EI}{3}\right) + \left(\frac{EI}{4}\right)} = 0.333$$

$$DF_{CB} = \frac{\left(\frac{EI}{3}\right)}{\left(\frac{EI}{3}\right) + 0} = 1$$

$DF_{CD} = 0$

Joint	A	B		C	
Member	AB	BA	BC	CB	CD
DF	0	0.667	0.333	1	0
FEM	0	0	-67.5	+67.5	-120
Dist. Moment	0	+45.022	+22.478	+52.5	0
CO	+22.511	0	+26.25	0	0
Dist. Moment	0	-17.509	-8.741	0	0
CO	-8.754	0	0	0	0
Dist. Moment	0	0	0	0	0
End moments	+13.757	+27.513	-27.013	+120	-120

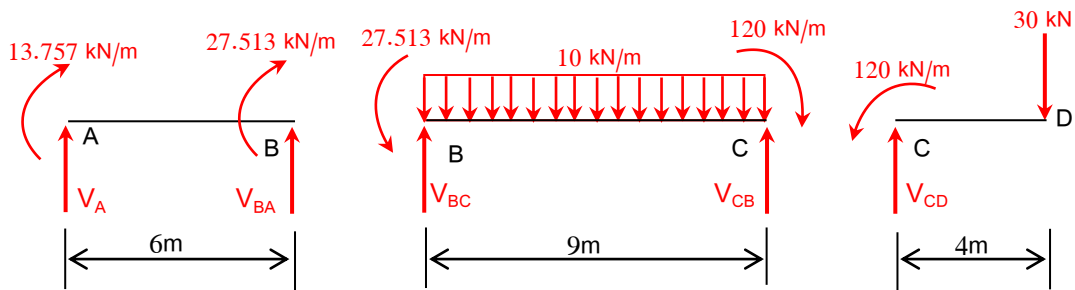

Member AB;

$$\sum M_B = V_A (6) + 13.757 + 27.513 = 0 \Rightarrow V_A = -6.878 \text{ kN (}\downarrow\text{)}$$

$$\sum F_y = -6.878 + V_{BA} = 0 \Rightarrow V_{BA} = +6.878 \text{ kN (}\uparrow\text{)}$$

Member BC;

$$\sum M_C = V_{BC} (9) - \frac{10 \times 9^2}{2} + 120 - 27.513 = 0 \Rightarrow V_{BC} = +34.724 \text{ kN (}\uparrow\text{)}$$

$$\sum F_y = 34.724 - 10 \times 9 + V_{CB} = 0 \Rightarrow V_{CB} = +55.276 \text{ kN (}\uparrow\text{)}$$

Member CD;

$$V_{CD} = 30 \text{ kN (}\uparrow\text{)}$$

$$\text{Hence } V_B = 6.878 + 34.724 = 41.602 \text{ kN (}\uparrow\text{)}$$

$$\text{and } V_C = 55.276 + 30.0 = 85.276 \text{ kN (}\uparrow\text{)}$$

$$\text{For check; } -6.878 + 41.602 + 85.276 = 120 = 30 + 10 \times 9 = 120 \text{ kN OK}$$

Theory of Structures

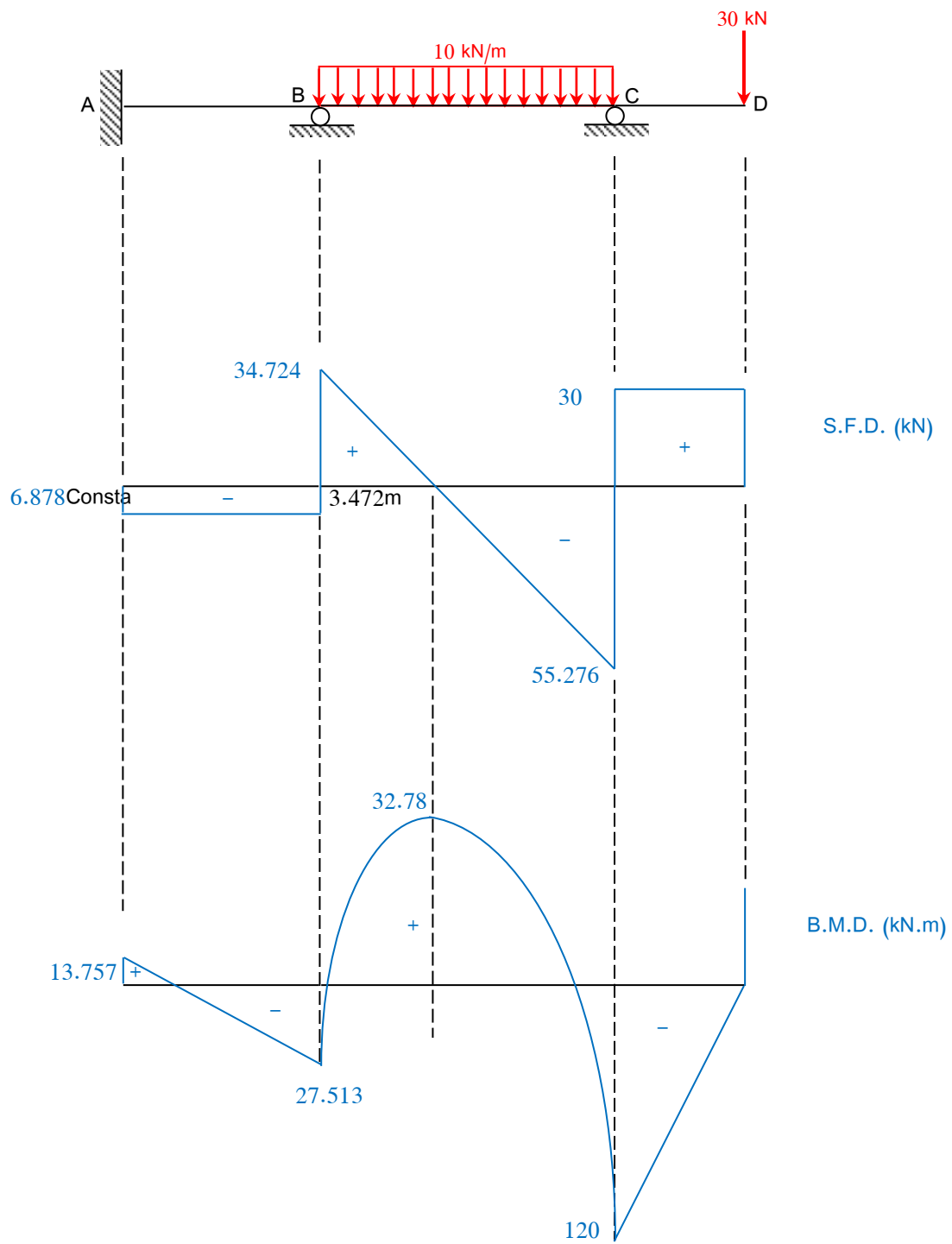

Support Settlement

The moment of the supports is an important design consideration, especially in bridges, as the movements can impose significant additional moments in the structure.

Consider the following movement which imposes moments on the beam;

$$t_{CA} = \frac{-FEM_{AB}}{EI} \left(\frac{1}{2}\right) \cdot \left(\frac{L}{2}\right) \cdot \left(\frac{2}{3} \times \frac{L}{2}\right)$$

$$= \frac{-FEM_{AB} \cdot L^2}{12EI}$$

$$t_{CA} = -\frac{\Delta}{2}$$

$$\frac{\Delta}{2} = \frac{FEM_{AB} \cdot L^2}{12EI}$$

$$FEM_{AB} = \frac{6EI\Delta}{L^2} = FEM_{BA}$$

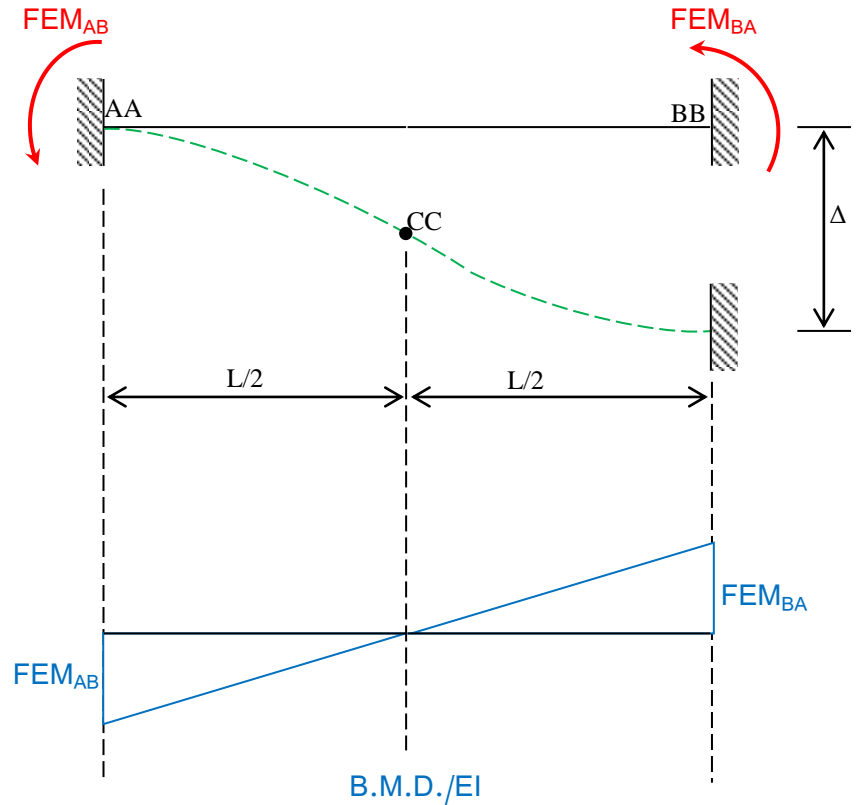

Example (4): Analyse the continuous beam ABC shown in figure using the moment-distribution method. Support " B " settles by (5mm) below A and C, EI is constant for all members, $E = 200\text{GPa}$ and $I = 8 \times 10^6 \text{ mm}^4$.

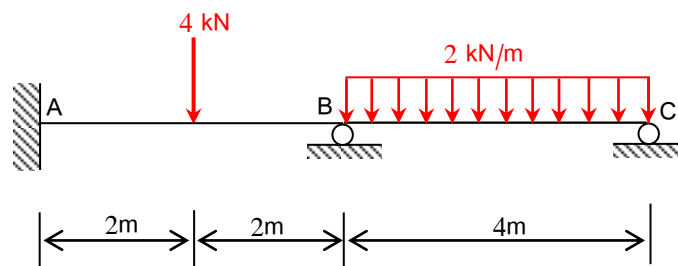

Solution

The fixed-end moments are;

$$FEM_{AB} = -\frac{PL}{8} - \frac{6EI\Delta}{L^2} = -\frac{4 \times 4}{8} - \frac{6 \times 200 \times 10^3 \times 8 \times 10^6 \times 5}{(4000)^2} \times 10^{-6} = -2 - 3 = -5 \text{ kN.m}$$

$$FEM_{BA} = +\frac{PL}{8} - \frac{6EI\Delta}{L^2} = +\frac{4 \times 4}{8} - \frac{6 \times 200 \times 10^3 \times 8 \times 10^6 \times 5}{(4000)^2} \times 10^{-6} = +2 - 3 = -1 \text{ kN.m}$$

$$FEM_{BC} = -\frac{\omega L^2}{12} + \frac{6EI\Delta}{L^2} = -\frac{2 \times 4^2}{12} + \frac{6 \times 200 \times 10^3 \times 8 \times 10^6 \times 5}{(4000)^2} \times 10^{-6} = -2.67 + 3 = +0.33 \text{ kN.m}$$

$$FEM_{CB} = +\frac{\omega L^2}{12} + \frac{6EI\Delta}{L^2} = +\frac{2 \times 4^2}{12} + \frac{6 \times 200 \times 10^3 \times 8 \times 10^6 \times 5}{(4000)^2} \times 10^{-6} = +2.67 + 3 = +5.67 \text{ kN.m}$$

The stiffness factors for the members are;

$$k_{AB} = \frac{4EI}{L} = \frac{4EI}{4} = EI$$

$$k_{BC} = \frac{3EI}{L} = \frac{3EI}{4}$$

The distribution factors are;

$$DF_{AB} = 0, DF_{CB} = 1$$

$$DF_{BA} = \frac{EI}{EI + (\frac{3EI}{4})} = 0.571$$

$$DF_{BC} = \frac{(\frac{3EI}{4})}{EI + (\frac{3EI}{4})} = 0.429$$

Joint	A	B		C
Member	AB	BA	BC	CB
DF	0	0.571	0.429	1
FEM	-5	-1	+0.33	+5.67
Dist. Moment	0	+0.383	+0.287	-5.67
CO	+0.191	0	-2.835	0
Dist. Moment	0	+1.619	+1.216	0
CO	+0.809	0	0	0
Dist. Moment	0	0	0	0
End moments	-4	+1.002	-1.002	0

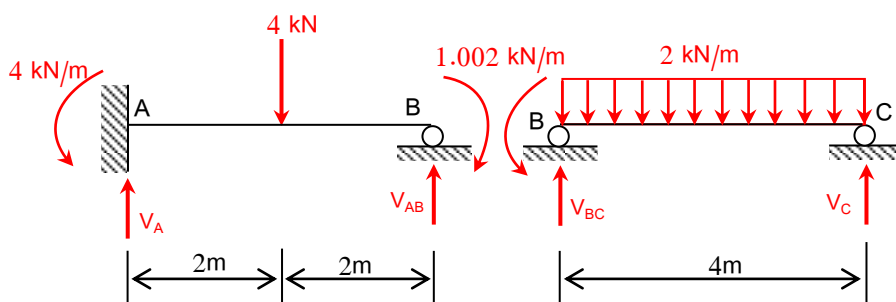

Member AB;

$$\sum M_B = V_A (4) - 4 \times 2 - 4 + 1.002 = 0 \quad \Rightarrow V_A = + 2.75 \text{ kN } (\uparrow)$$

$$\sum F_y = +2.75 - 4 + V_{BA} = 0 \quad \Rightarrow V_{BA} = + 1.25 \text{ kN } (\uparrow)$$

Member BC;

$$\sum M_B = V_C (4) - \frac{2 \times 4^2}{2} + 1.002 = 0 \quad \Rightarrow V_C = + 3.75 \text{ kN } (\uparrow)$$

$$\sum F_y = 3.75 - 4 \times 2 + V_{BC} = 0 \quad \Rightarrow V_{BC} = + 4.25 \text{ kN } (\uparrow)$$

Hence $V_B = 1.25 + 4.25 = 5.5 \text{ kN } (\uparrow)$

For check; $2.75 + 5.5 + 2.75 = 12 = 4 + 2 \times 4 = 12 \text{ kN } \quad \text{OK}$

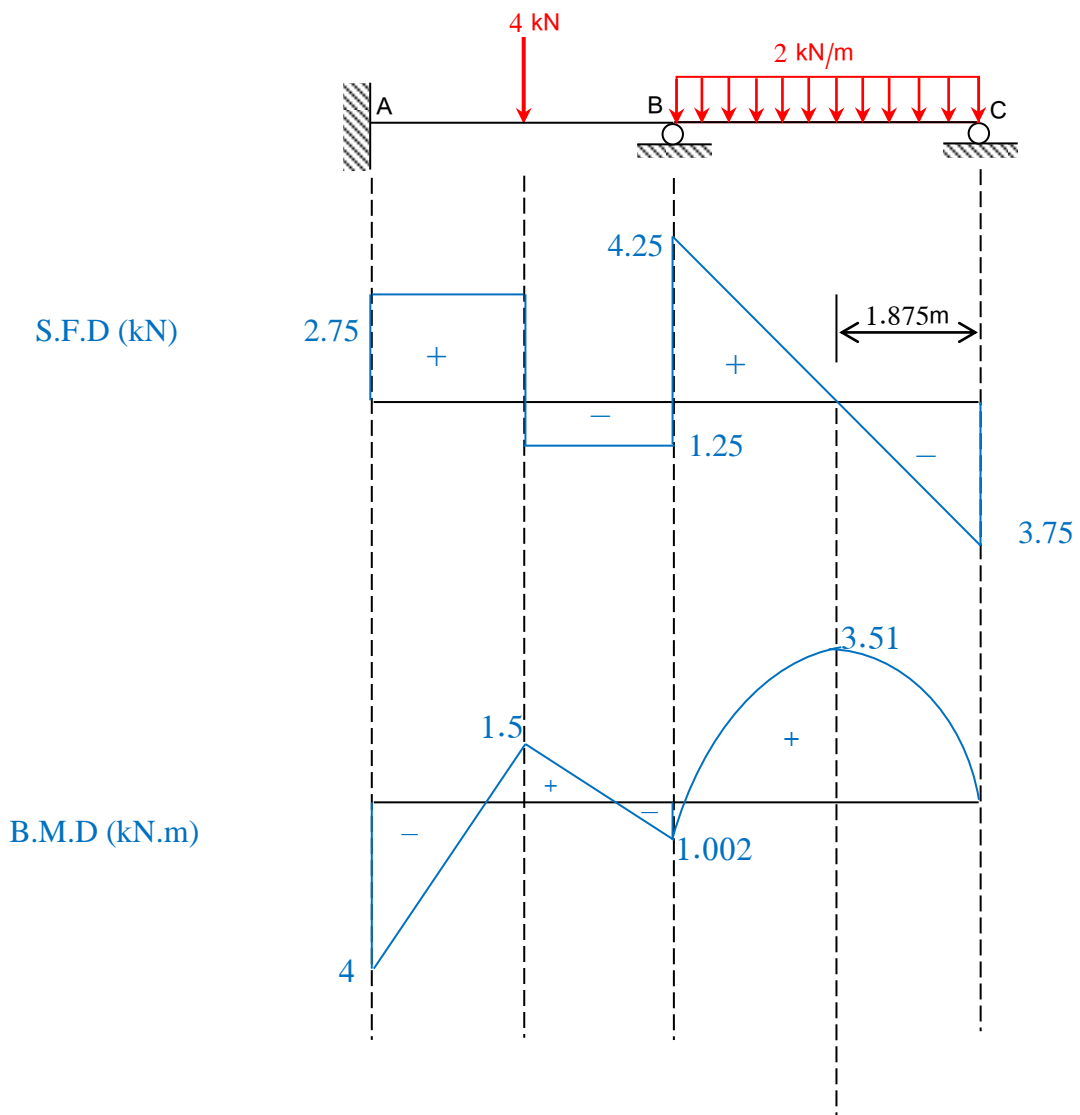

Application of moment-Distribution to Frames without Sidesway

The application of the moments distribution method to the analysis of statically indeterminate frames where no sidesway is involved is similar to that of beams, except that in the case of frames there are more than two members meeting in one joint.

Example (5): Analyse the frame shown in the figure using the moment-distribution method and draw the shear force and bending moment diagrams.

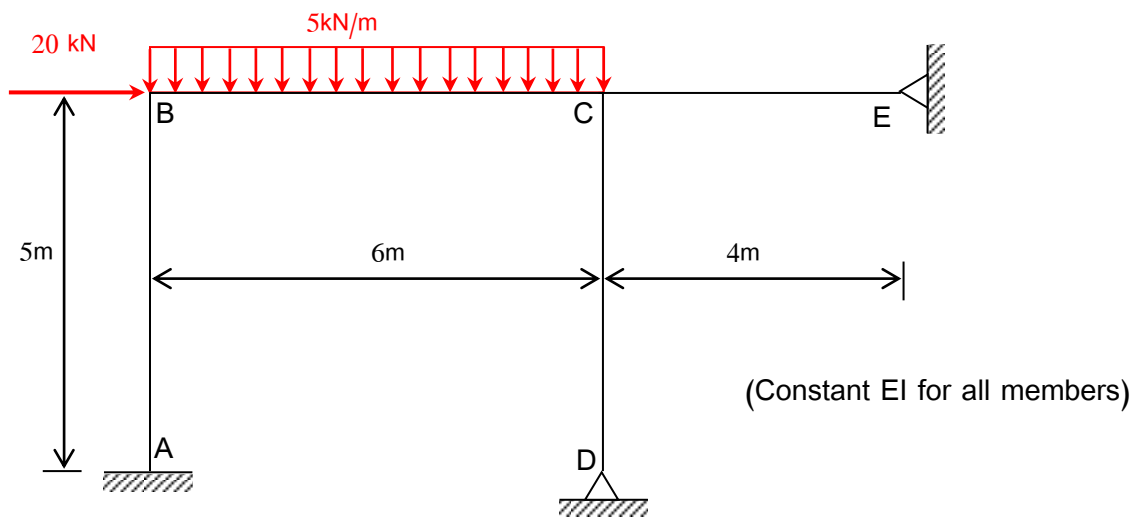

Solution

The fixed-end moments are;

$$FEM_{AB} = FEM_{BA} = FEM_{CD} = FEM_{DC} = FEM_{CE} = FEM_{EC} = 0$$

$$FEM_{BC} = -\frac{\omega L^2}{12} = -\frac{5 \times 6^2}{12} = -15 \text{ kN.m}$$

$$FEM_{CB} = +\frac{\omega L^2}{12} = +\frac{5 \times 6^2}{12} = +15 \text{ kN.m}$$

The stiffness factors for the members are;

$$k_{AB} = \frac{4EI}{5} \quad , \quad k_{BC} = \frac{4EI}{6} \quad , \quad k_{CD} = \frac{3EI}{5} \quad , \quad k_{CE} = \frac{3EI}{4}$$

The distribution factors are;

$$DF_{AB} = 0 \quad , \quad DF_{DC} = DF_{EC} = 1$$

$$DF_{BA} = \frac{\frac{4EI}{5}}{\frac{4EI}{5} + \frac{4EI}{6}} = 0.545$$

$$DF_{BC} = \frac{\frac{4EI}{6}}{\frac{4EI}{5} + \frac{4EI}{6}} = 0.455$$

Theory of Structures

$$DF_{CB} = \frac{\frac{4EI}{6}}{\frac{4EI}{6} + \frac{3EI}{5} + \frac{3EI}{4}} = 0.330$$

$$DF_{CD} = \frac{\frac{3EI}{5}}{\frac{4EI}{6} + \frac{3EI}{5} + \frac{3EI}{4}} = 0.298$$

$$DF_{CE} = \frac{\frac{3EI}{4}}{\frac{4EI}{6} + \frac{3EI}{5} + \frac{3EI}{4}} = 0.372$$

Joint	A	B		C			D	E
Member	AB	BA	BC	CB	CD	CE	DC	EC
DF	0	0.545	0.455	0.330	0.298	0.372	1	1
FEM	0	0	-15	+15	0	0	0	0
Dist. Moment	0	+8.175	+6.825	- 4.95	- 4.47	- 5.58	0	0
CO	+4.087	0	- 2.475	+3.412	0	0	0	0
Dist. Moment	0	+1.349	+1.126	-1.126	- 1.017	- 1.269	0	0
CO	+0.674	0	- 0.563	+0.563	0	0	0	0
Dist. Moment	0	+0.307	+0.256	-0.186	-0.168	-0.209	0	0
CO	+0.153	0	-0.093	+0.128	0	0	0	0
Dist. Moment	0	+0.051	+0.042	-0.042	-0.038	-0.048	0	0
CO	+0.025	0	-0.021	+0.021	0	0	0	0
Dist. Moment	0	+0.011	+0.010	-0.007	-0.006	-0.008	0	0
CO	+0.005	0	-0.003	+0.005	0	0	0	0
Dist. Moment	0	+0.002	+0.001	-0.002	-0.001	-0.002	0	0
CO	+0.001	+0.000	-0.001	0.000	0	0	0	0
Dist. Moment	0	0.000	0.000	0.000	0.000	0.000	0	0
End moments	+4.945	+9.895	-9.896	+12.816	-5.700	-7.116	0	0

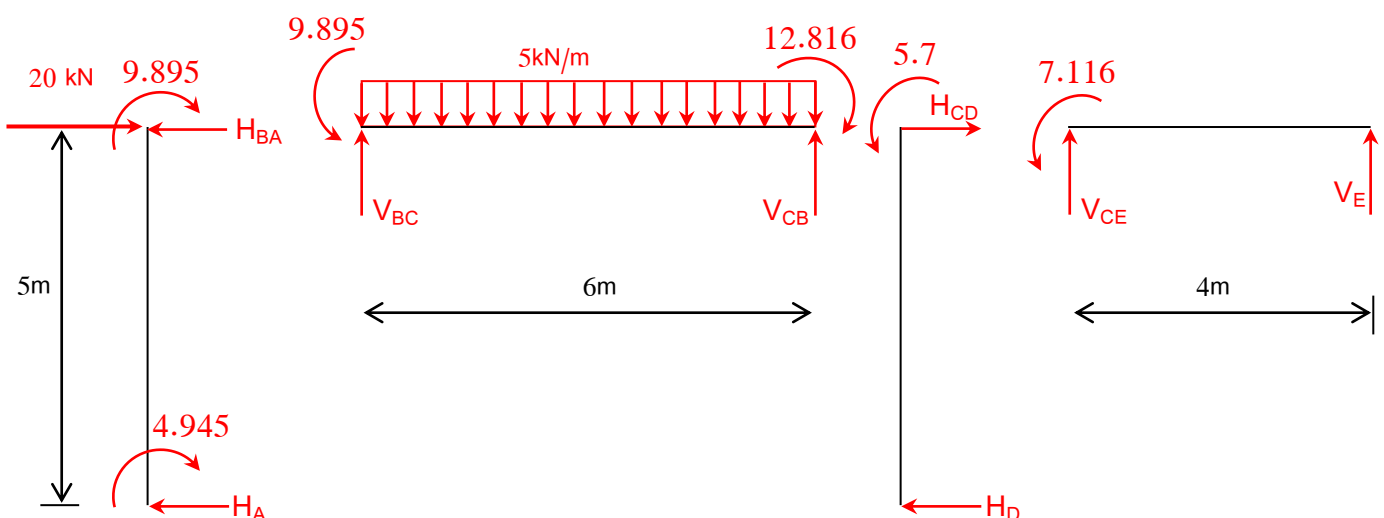

Member AB;

$$\sum M_B = H_A (5) + 4.945 + 9.895 = 0$$

$$\Rightarrow H_A = - 2.968 \text{ kN (} \rightarrow \text{)}$$

$$\sum F_x = +20.0 + 2.968 - H_{BA} = 0$$

$$\Rightarrow H_{BA} = + 22.968 \text{ kN (} \leftarrow \text{)}$$

Member BC;

$$\sum M_C = V_{BC} (6) - \frac{5 \times 6^2}{2} - 9.895 + 12.816 = 0$$

$$\Rightarrow V_{BC} = + 14.51 \text{ kN (} \uparrow \text{)}$$

$$\sum F_y = +14.51 - 5 \times 6 + V_{CB} = 0$$

$$\Rightarrow V_{CB} = + 15.49 \text{ kN (} \uparrow \text{)}$$

Member CD;

$$\sum M_C = H_D (5) - 5.7 = 0$$

$$\Rightarrow H_D = + 1.14 \text{ kN (} \leftarrow \text{)}$$

$$\sum F_x = H_{CD} - 1.14 = 0$$

$$\Rightarrow H_{CD} = + 1.14 \text{ kN (} \rightarrow \text{)}$$

Member CE;

$$\sum M_C = V_E (4) + 7.116 = 0$$

$$\Rightarrow V_E = - 1.779 \text{ kN (} \downarrow \text{)}$$

$$\sum F_y = - 1.779 + V_{CE} = 0$$

$$\Rightarrow V_{CE} = + 1.779 \text{ kN (} \uparrow \text{)}$$

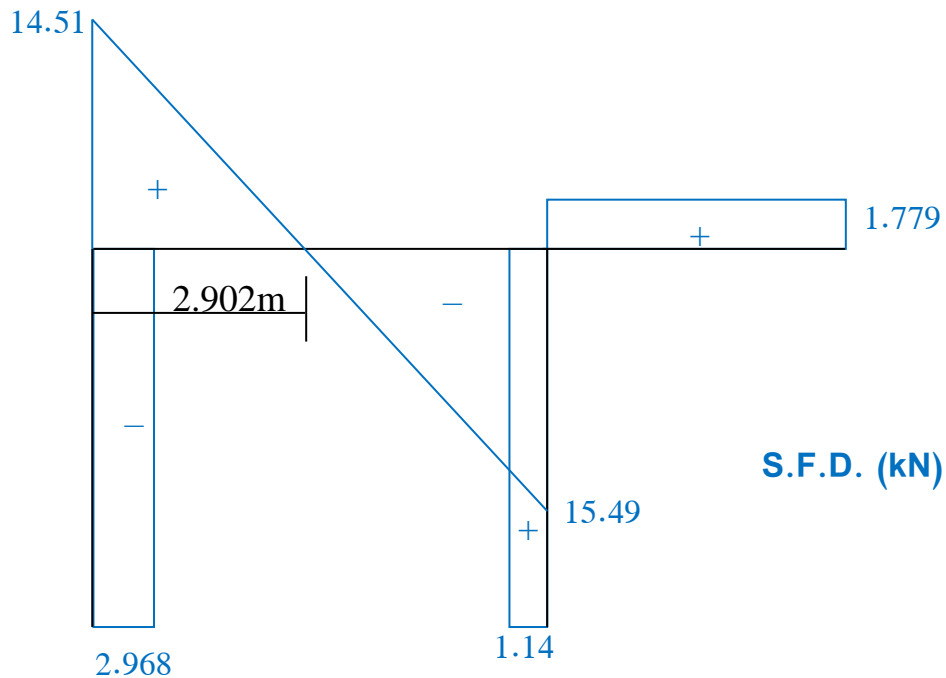

$$14.51 \times 2.902 - 9.895 - [5 \times (2.902)^2] / 2 = 11.15$$

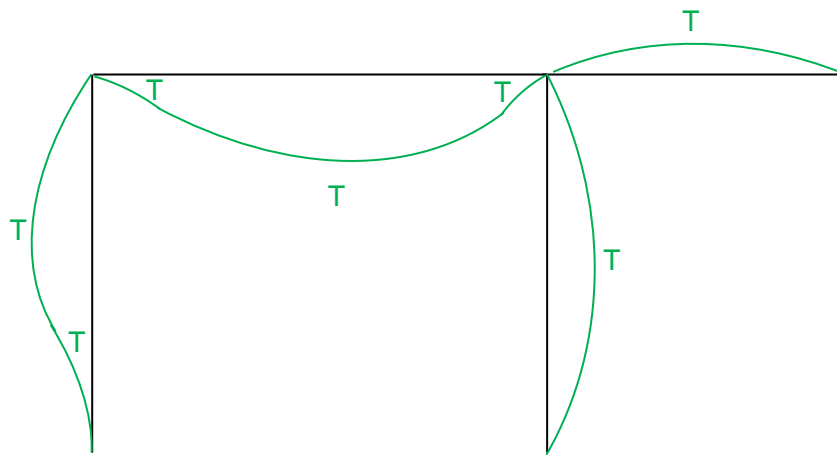
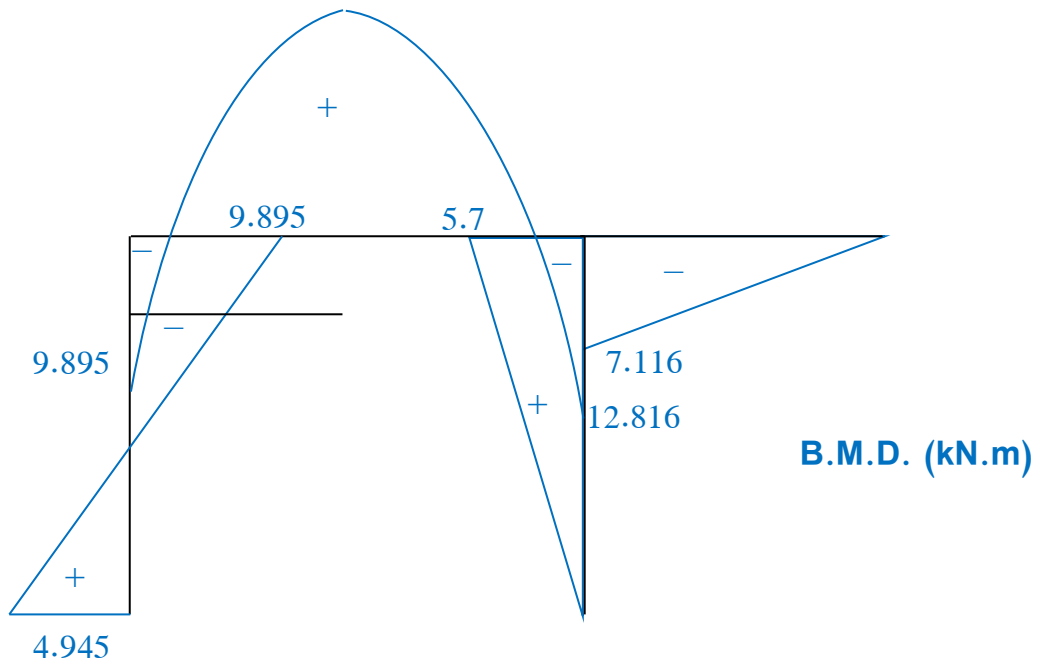

Deflected Shape Diagram

Chapter Nine

Energy Methods

General

When an external force (i.e. axial load or moment) acts on an elastic body, it deforms. If the elastic limit is not exceeded, the work done in straining the material is stored in the form of strain energy. By equating the external work done by applied loads as they deform the elastic body to the internal strain energy stored in the body, we obtain a method of determining deflections that is based on the principle of conservation of energy.

The energy principles are also applied to the analysis of redundant systems.

In pin-jointed structures, where the members are in tension or compression, the energy stored depends on direct forces only. However, in beams and rigid-joint frames, shear stress and bending stress may also occur at any section, and the total strain energy store depends on the magnitudes of direct force, shear, and moment.

In the analysis of statically indeterminate structures, the work done by direct and shear forces is *neglected* since it is very small compared to that done by bending

Strain Energy in Linear Elastic system

i – Axial Loading

If an axial load " P " is applied gradually, and if the bar undergoes a deformation (Δ), the (Load) work done stored as strain energy (u) in the body, will be equal to the average force ($\frac{1}{2} P$) multiplied by the deformation (Δ).

$$\text{Thus } u = \frac{1}{2} P \cdot \Delta$$

$$\text{But } \Delta = \frac{PL}{AE} \quad \text{from Hooke's Law}$$

$$u = \frac{1}{2} P \cdot \frac{PL}{AE} = \frac{P^2 L}{2AE}$$

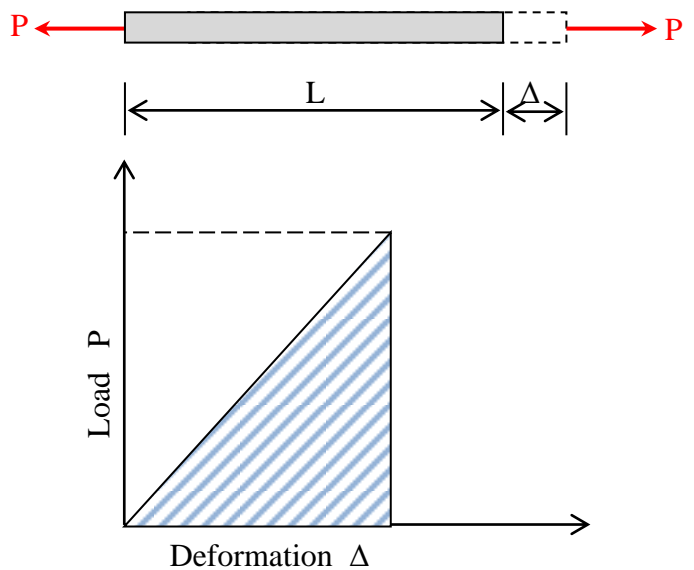

If the bar has variable area of cross-section, consider a small section of length " dx " and area of cross-section " A_x ". The strain energy stored in this small element " dx " will be;

$$du = \frac{P^2}{2A_x E} \cdot dx$$

and the total strain energy " u " will be

$$u = \int_0^L \frac{P^2}{2A_x E} \cdot dx$$

ii- Flexural Loading (Moment or Couple):

Consider a member of length " L " subjected to uniform bending moment " M ". For an element of length " dx ", let " dθ " be the change in slope due to the applied moment " M ". If " M " is applied gradually, the strain energy stored in the small

element $du = \frac{1}{2} M \cdot d\theta$

$$\text{But } \frac{d\theta}{dx} = \frac{d}{dx} \left(\frac{dy}{dx} \right) = \frac{d^2y}{dx^2} = \frac{M}{EI}$$

$$d\theta = \frac{M}{EI} \cdot dx$$

$$\text{Hence; } du = \frac{1}{2} M \cdot \frac{M}{EI} \cdot dx = \frac{M^2}{2EI} \cdot dx$$

Integrating over the entire length, we get the total strain energy stored in the member.

$$u = \int_0^L \frac{M^2}{2EI} \cdot dx$$

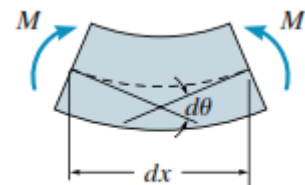
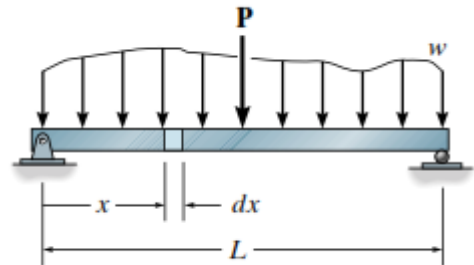

Castigliano's Theorem Method

The concept of the elastic strain energy can be very useful in the study of deflections of various points of structure under load.

Instead of directly equating the external work to the internal strain energy, considerable simplification is obtained by " Castigliano's Theorem " which states that the deflection caused by any external force is equal to the partial derivative of the strain energy with respect to that force, i.e.

$$\frac{\partial u}{\partial P_i} = \Delta_i$$

Proof:

Consider an elastic body subjected to loads $P_1, P_2, P_3, P_i, \dots$ each applied independently. Let $\Delta_1, \Delta_2, \Delta_3, \Delta_i, \dots$ be the deflection of points 1, 2, 3, 3, i, in the direction of the loads at these points.

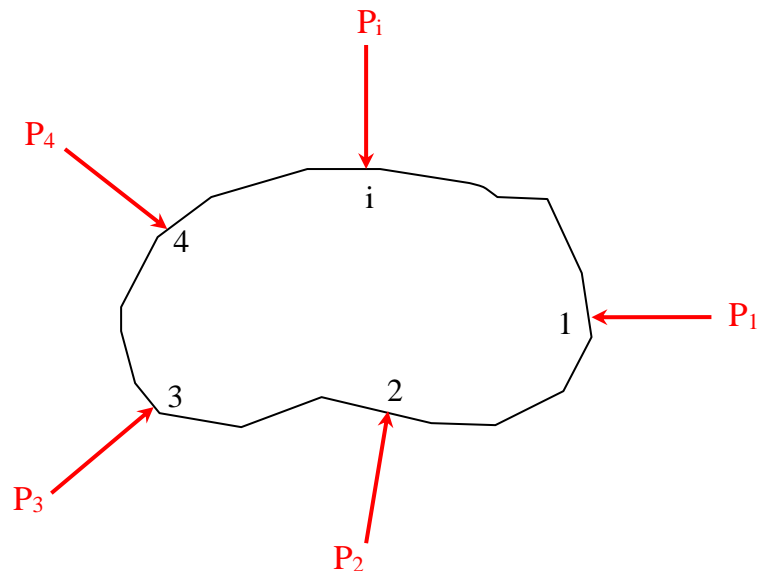

If all the loads are applied simultaneously, the total strain energy is given by;

$$u = \frac{1}{2}P_1\Delta_1 + \frac{1}{2}P_2\Delta_2 + \frac{1}{2}P_3\Delta_3 + \frac{1}{2}P_i\Delta_i + \dots \quad \text{----- (1)}$$

If the load " P_1 " is increased by an amount " dP_1 ", after the loads have been applied, there will be a slight increase in the strain energy given by;

$$du = \frac{\partial u}{\partial P_1} \cdot dP_1 \quad \text{----- (2)}$$

and the new strain energy will be;

$$u + \frac{\partial u}{\partial P_1} \cdot dP_1 \quad \text{----- (3)}$$

Assuming that dP_1 acts on the body prior to the application of $P_1, P_2, P_3, P_i, \dots$, the strain energy due to these loads will be the same as given in expression (1).

However, the small load dP_1 which acts prior to the application of P_1 , rides through the displacement Δ_1 and produces the energy increase;

$$du = (dP_1) \cdot \Delta_1 \quad \text{----- (4)}$$

and the new strain energy is given by;

$$u + (dP_1) \cdot \Delta_1 \quad \text{----- (5)}$$

Since the final strain energy does not depend on the order in which the forces are applied, we obtain by equating (3) and (5);

$$u + \frac{\partial u}{\partial P_1} \cdot dP_1 = u + (dP_1) \cdot \Delta_1$$

$$\text{or } \Delta_1 = \frac{\partial u}{\partial P_1}$$

Similarly, it can be proved that $\theta = \frac{\partial u}{\partial M_1}$

Example (1): calculate the deflection under the load " P " for the cantilever shown in figure.

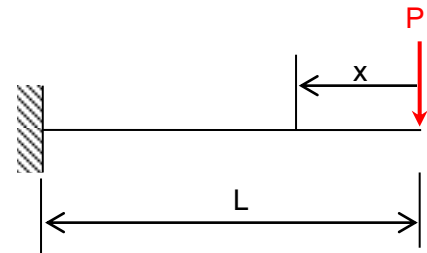

$EI = \text{Constant}$

Solution

The strain energy; $u = \int_0^L \frac{M^2}{2EI} \cdot dx$

$$M = - P \cdot x$$

$$u = \int_0^L \frac{P^2 x^2}{2EI} \cdot dx$$

The deflection under " P " is;

$$\Delta = \frac{\partial u}{\partial P}$$

$$= \frac{\partial}{\partial P} \int_0^L \frac{P^2 x^2}{2EI} \cdot dx$$

The above expression is easier to evaluate by differentiating inside the integral sign before integrating. This is permissible because " P " is not a function of " x " .

$$\Delta = \frac{1}{2EI} \int_0^L \frac{\partial}{\partial P} (P^2 x^2) \cdot dx$$

$$= \frac{1}{2EI} \int_0^L 2P \cdot x^2 dx = \frac{P}{EI} \cdot \frac{L^3}{3} = \frac{PL^3}{3EI}$$

Example (2): Calculate the vertical deflection under the 1kN shown in Figure.

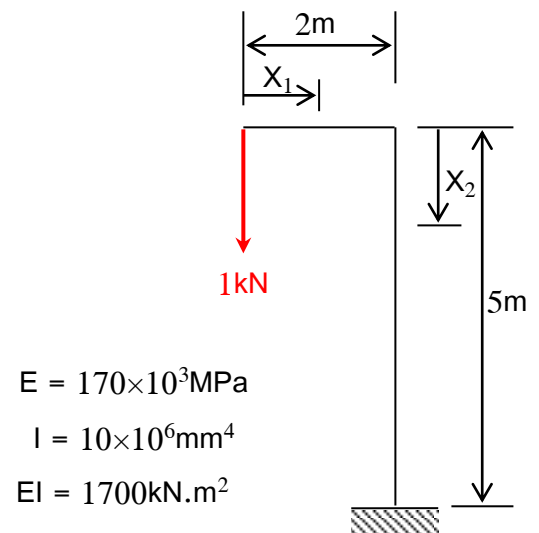

Solution

The energy calculations are performed in terms of " P " instead of (1kN) load, so that differentiation may be carried out in terms of " P ", and $P = 1 \text{ kN}$ is substituted in the final expression.

The strain energy stored in the structure;

$$u = u_1 + u_2$$

$$u_1 = \int_0^2 \frac{M_1^2}{2EI} dx_1 = \int_0^2 \frac{(-P \cdot x_1)^2}{2EI} dx_1$$

$$u_2 = \int_0^5 \frac{M_2^2}{2EI} dx_2 = \int_0^5 \frac{(-2P)^2}{2EI} dx_2$$

The deflection is $\Delta = \frac{\partial u}{\partial P} = \frac{\partial u_1}{\partial P} + \frac{\partial u_2}{\partial P}$

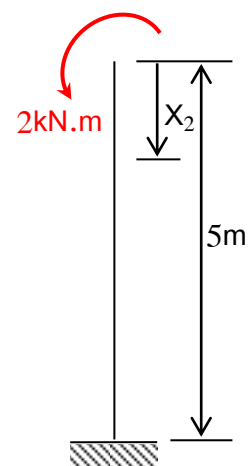

$$\begin{aligned}
 \Delta &= \frac{\partial}{\partial P} \int_0^2 \frac{(-P \cdot x_1)^2}{2EI} dx_1 + \frac{\partial}{\partial P} \int_0^5 \frac{(-2P)^2}{2EI} dx_2 \\
 &= \int_0^2 \frac{\partial}{\partial P} \cdot \frac{P^2 \cdot x_1^2}{2EI} dx_1 + \int_0^5 \frac{\partial}{\partial P} \cdot \frac{4P^2}{2EI} dx_2 \\
 &= \frac{P}{EI} \int_0^2 x_1^2 dx_1 + \frac{4P}{EI} \int_0^5 dx_2 = \frac{P}{EI} \left[\frac{x_1^3}{3} \right]_0^2 + \frac{4P}{EI} [x_2]_0^5 = \frac{P}{EI} \left[\frac{8}{3} + 4(5) \right] \\
 &= \frac{1}{1700} (22.667) = 0.013\text{m}
 \end{aligned}$$

Example (3): Calculate the deflection at the free end for the cantilever shown in figure.

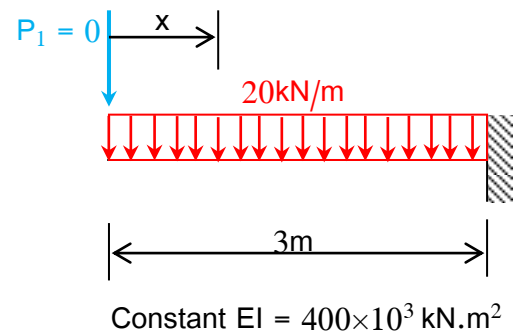

Solution

Assume a fictitious load $P_1 = 0$ at the free end, and calculate the strain energy in terms of the uniform load (20 kN/m) and P_1 .

$$\begin{aligned}
 M &= -P_1 \cdot x - 20 \left(\frac{x^2}{2} \right) = -P_1 \cdot x - 10x^2 \\
 u &= \int_0^3 \frac{M^2}{2EI} dx \\
 \Delta &= \frac{\partial u}{\partial P_1} \\
 &= \frac{\partial}{\partial P_1} \int_0^3 \frac{M^2}{2EI} dx = \int_0^3 \frac{\partial}{\partial P_1} \left(\frac{M^2}{2EI} \right) dx \\
 &= \int_0^3 \frac{2M}{2EI} \cdot \frac{\partial M}{\partial P_1} dx = \int_0^3 \frac{M}{EI} \cdot \frac{\partial M}{\partial P_1} dx \\
 \frac{\partial M}{\partial P_1} &= -x \\
 \Delta &= \int_0^3 \frac{(-P_1 \cdot x - 10x^2)}{EI} \cdot (-x) dx \\
 \text{Substitute } P_1 &= 0 \text{ in the above expression,} \\
 \Delta &= \int_0^3 \frac{10x^3}{EI} dx = \frac{10}{EI} \cdot \left[\frac{x^4}{4} \right]_0^3 = \frac{10}{400 \times 10^3} \cdot \frac{81}{4} = 0.506 \times 10^{-3} \text{ m} = 0.506 \text{ mm}
 \end{aligned}$$

Example (4): Calculate the rotation at the free end for the cantilever shown in figure.

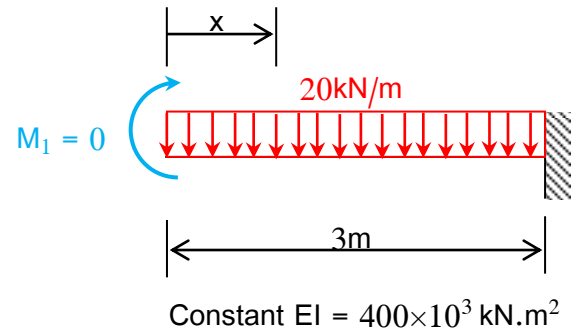

Solution

Assume a fictitious moment $M_1 = 0$ at the free end.

The rotation at the free end is given by;

$$\theta = \frac{\partial u}{\partial M_1}$$

Where $u = \int_0^3 \frac{M^2}{2EI} dx$

$$\begin{aligned} \text{Hence, } \theta &= \frac{\partial}{\partial M_1} \int_0^3 \frac{M^2}{2EI} dx = \int_0^3 \frac{\partial}{\partial M_1} \left(\frac{M^2}{2EI} dx \right) \\ &= \int_0^3 \frac{2M}{2EI} \cdot \frac{\partial M}{\partial M_1} dx = \int_0^3 \frac{M}{EI} \cdot \frac{\partial M}{\partial M_1} dx \end{aligned}$$

The bending moment at a distance " x " from the free end is;

$$M = M_1 - 20 \left(\frac{x^2}{2} \right) = M_1 - 10 x^2$$

$$\frac{\partial M}{\partial M_1} = 1$$

$$\theta = \int_0^3 \frac{(M_1 - 10x^2)}{EI} \cdot (1) dx$$

Putting $M_1 = 0$

$$\text{So, } \theta = \int_0^3 \frac{(-10x^2)}{EI} dx = - \frac{10}{EI} \cdot \frac{x^3}{3}$$

$$= - \frac{10}{400 \times 10^3} \times \frac{27}{3} = -0.225 \times 10^{-3} \text{ rad.}$$

The negative sign indicates that the rotation θ is opposite to the applied moment M_1 .

Joint Displacement in Trusses

Castigliano's theorem may be used to calculate the displacement of joints in trusses.

If " F " is the axial force in a truss member of length " L " and stiffness " EA ", then the strain energy stored in the member is $\frac{F^2L}{2EA}$, and the energy stored in the truss is $u = \sum \frac{F^2L}{2EA}$.

To find the displacement of a joint in a given direction, a force " P_i " is assumed at the joint, and the required displacement is;

$$\Delta_i = \frac{\partial u}{\partial P_i}$$

$$\Delta_i = \sum \frac{\partial F}{\partial P_i} \cdot \frac{FL}{EA}$$

Example (1): Calculate the vertical deflection for point (2) of the truss shown in the figure.

$$E = 200\text{kN/mm}^2$$

$$A = 500\text{mm}^2 \text{ (for bars in tension)}$$

$$A = 800\text{mm}^2 \text{ (for bars in compression)}$$

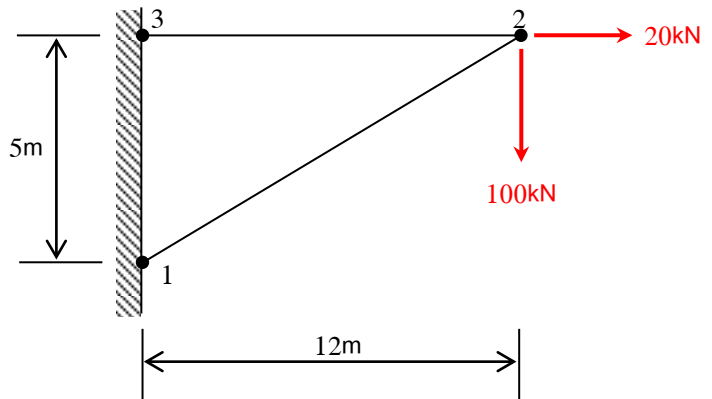

Solution

The symbol " P " is used for the vertical load (100kN) and the axial forces in the bars are calculated in terms of " P " and the other applied loads.

From equilibrium of joint (2);

$$\sum F_y = 0 \Rightarrow F_{1-2} \sin\theta + P = 0$$

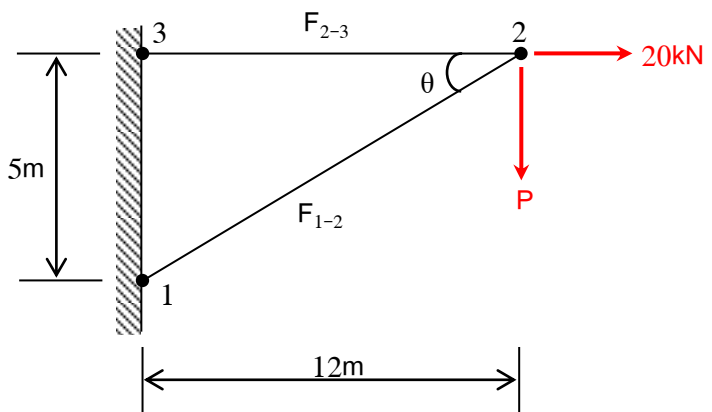

Theory of Structures

$$F_{1-2} = -\frac{P}{\sin\theta} = -\frac{13}{5} P = -2.6 P$$

$$\frac{\partial F_{1-2}}{\partial P} = -2.6$$

Also,

$$\sum F_x = 0 \Rightarrow F_{1-2} \cos\theta + F_{2-3} - 20 = 0$$

$$F_{2-3} = 20 - F_{1-2} \cos\theta = 20 - \left(-\frac{13}{5} P\right) \left(\frac{12}{13}\right)$$

$$F_{2-3} = 20 + 2.4 P$$

$$\frac{\partial F_{2-3}}{\partial P} = 2.4$$

Make a table for calculations, and substitute for $P = 100$ kN

Bar	Area (mm ²)	E (kN/mm ²)	Length (mm)	Axial load (kN)	$\frac{\partial F}{\partial P}$	$\frac{\partial F}{\partial P} \cdot \frac{FL}{EA}$
(1-2)	800	200	13000	-260	-2.6	54.93
(2-3)	500	200	12000	+260	2.4	74.88

$$\Delta_2 = \sum \frac{\partial F}{\partial P_i} \cdot \frac{FL}{EI} = 54.93 + 74.88 = 129.81 \text{ mm}$$

Applications of Castigliano's Theorem to Statically Indeterminate Structures

i- Beams:

If the number of the external unknowns is greater than the equations of equilibrium, the strain energy is calculated in terms of the redundants and given loads.

The required additional equations are then obtained from the displacement of these redundants (which are usually equal to zero).

If x_i is one of the redundants, then (usually);

$$\frac{\partial u}{\partial x_i} = \Delta_i = 0$$

Example (1): Calculate the external reactions for the beam shown in the figure.

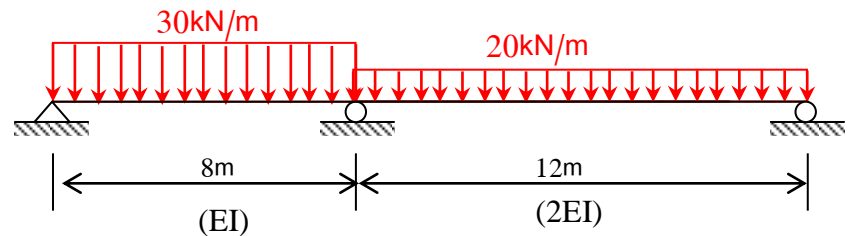

Solution

The beam is statically indeterminate to the first degree.

Taking R_1 as the redundant, the strain energy is calculated in terms of R_1 and the given loads.

The beam consists of two segments, therefore;

$$u = u_1 + u_2$$

For the left-hand segment;

$$u_1 = \int_0^8 \frac{M^2}{2EI} dx$$

$$M = R_1 \cdot x - 30 \left(\frac{x^2}{2} \right)$$

$$\frac{\partial M}{\partial R_1} = x$$

$$\frac{\partial u_1}{\partial R_1} = \int_0^8 \frac{\partial M}{\partial R_1} \cdot \frac{M}{EI} dx = \frac{1}{EI} \int_0^8 x \cdot (R_1 \cdot x - 15x^2) dx = \frac{1}{EI} \int_0^8 (R_1 \cdot x^2 - 15x^3) dx$$

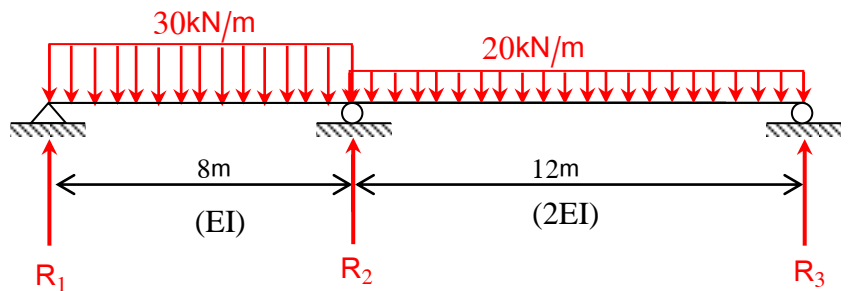

$$= \frac{1}{EI} \left[R_1 \cdot \frac{x^3}{3} - 15 \cdot \frac{x^4}{4} \right]_0^8 = \frac{1}{EI} \left[R_1 \cdot \frac{8^3}{3} - 15 \cdot \frac{8^4}{4} \right]$$

$$= \frac{512}{EI} \left(\frac{R_1}{3} - 30 \right)$$

For the right-hand segment, the bending moment at a distance " x " from R_3 is;

$$M = R_3 \cdot x - 20 \left(\frac{x^2}{2} \right)$$

From $\sum M = 0$ about R_2 for the whole beam;

$$R_1(8) - 30(8)(4) + 20(12)(6) - R_3(12) = 0 \Rightarrow 12 R_3 = 8 R_1 + 480$$

$$R_3 = \frac{2}{3} R_1 + 40$$

Writing " M " in terms of R_1 ;

$$M = \left(\frac{2}{3} R_1 + 40 \right) \cdot x - 10x^2$$

$$\frac{\partial M}{\partial R_1} = \frac{2}{3} x$$

$$u_2 = \int_0^{12} \frac{M^2}{2(2EI)} dx$$

$$\frac{\partial u_2}{\partial R_1} = \int_0^{12} \frac{\partial M}{\partial R_1} \cdot \frac{M}{2EI} dx$$

$$\frac{\partial u_2}{\partial R_1} = \frac{1}{2EI} \int_0^{12} \frac{2}{3} x \cdot \left(\frac{2}{3} R_1 \cdot x + 40 \cdot x - 10x^2 \right) dx$$

$$= \frac{1}{3EI} \int_0^{12} \left(\frac{2}{3} R_1 \cdot x^2 + 40 \cdot x^2 - 10x^3 \right) dx = \frac{1}{3EI} \left[\frac{2}{3} R_1 \cdot \frac{x^3}{3} + 40 \cdot \frac{x^3}{3} - 10 \frac{x^4}{4} \right]_0^{12}$$

$$= \frac{1}{3EI} \left[\frac{2}{3} \cdot \frac{12^3}{3} \cdot R_1 + 40 \cdot \frac{12^3}{3} - 10 \frac{12^4}{4} \right] = \frac{12^3}{3EI} \left(\frac{2}{9} R_1 + \frac{40}{3} - 30 \right)$$

$$= \frac{576}{EI} \left(\frac{2}{9} R_1 - \frac{50}{3} \right)$$

$$= \frac{192}{EI} \left(\frac{2}{3} R_1 - 50 \right)$$

$$\Delta_1 = \frac{\partial u}{\partial R_1} = \frac{\partial u_1}{\partial R_1} + \frac{\partial u_2}{\partial R_1} = 0$$

$$\frac{512}{EI} \left(\frac{R_1}{3} - 30 \right) + \frac{192}{EI} \left(\frac{2}{3} R_1 - 50 \right) = 0$$

$$\frac{R_1}{3} - 30 + \frac{R_1}{4} - 18.75 = 0$$

Theory of Structures

$$R_1 = 83.57 \text{ kN } (\uparrow)$$

$$R_3 = 95.71 \text{ kN } (\uparrow)$$

$$R_2 = 300.72 \text{ kN } (\uparrow)$$

$$\Sigma = 480 \text{ kN} = 30 \times 8 + 20 \times 12$$

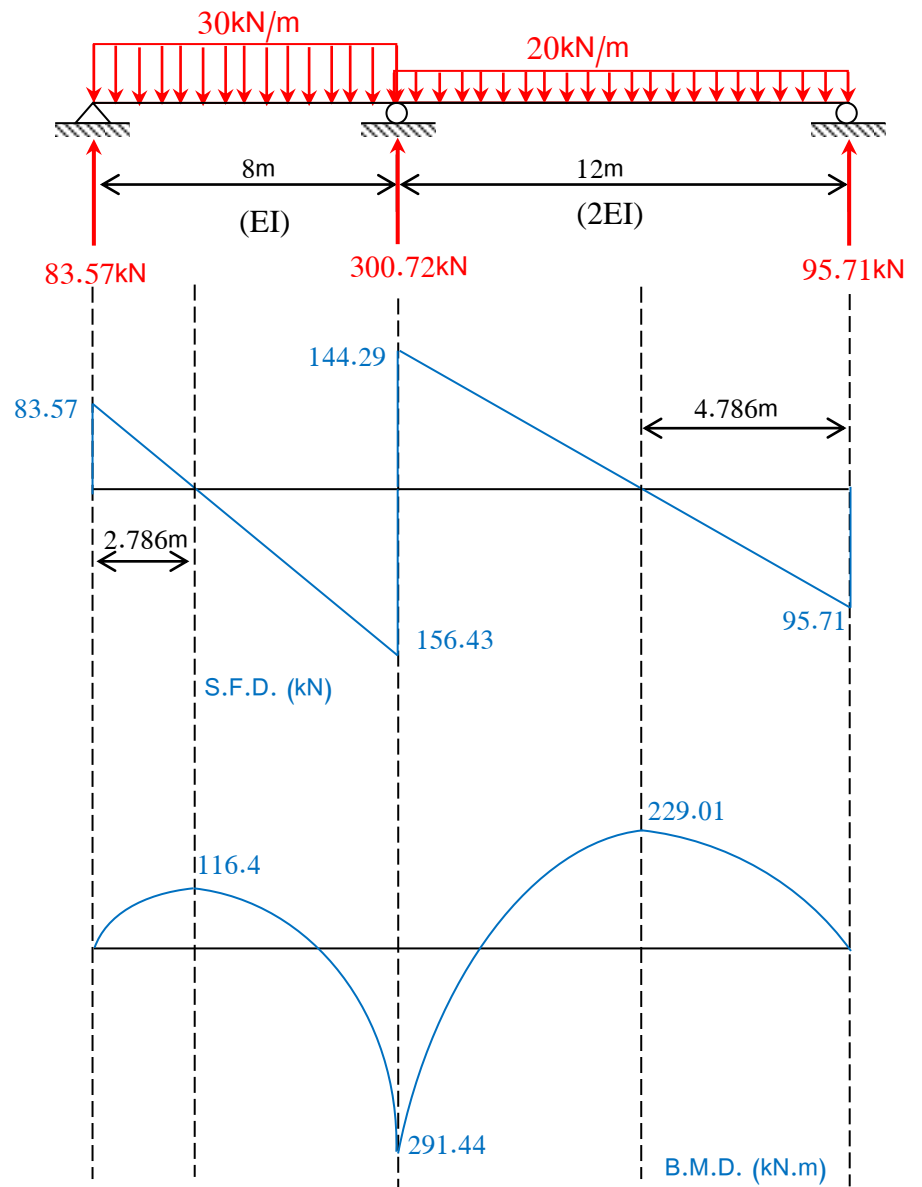

ii- Frames:

Example (2): Calculate the reactions and draw the shear force and bending moment diagrams for the frame shown in the figure. ($EI = \text{Constant}$)

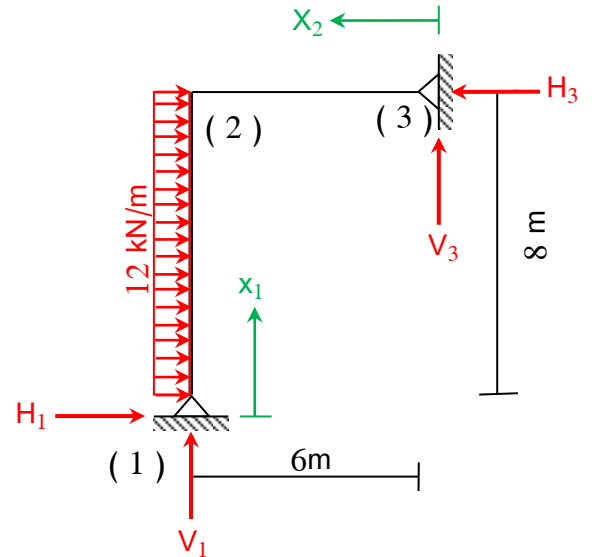

Solution

There are four unknowns and three equations of equilibrium.

Select (H_1) as a redundant,

$$u = u_{1-2} + u_{2-3}$$

$$\Delta_1 = \frac{\partial u}{\partial H_1} = \frac{\partial u_{1-2}}{\partial H_1} + \frac{\partial u_{2-3}}{\partial H_1} = 0$$

For the segment 1-2;

$$M = -H_1 \cdot x_1 - 12 \frac{x_1^2}{2} = -H_1 \cdot x_1 - 6 x_1^2$$

$$\frac{\partial M}{\partial H_1} = -x_1$$

$$u_{1-2} = \int_0^8 \frac{M^2}{2EI} dx_1$$

$$\frac{\partial u_{1-2}}{\partial H_1} = \int_0^8 \frac{\partial M}{\partial H_1} \cdot \frac{M}{EI} dx_1 = \frac{1}{EI} \int_0^8 (-x_1)(-H_1 \cdot x_1 - 6 x_1^2) dx_1$$

$$= \frac{1}{EI} \int_0^8 (H_1 \cdot x_1^2 + 6 x_1^3) dx_1 = \frac{1}{EI} \left[H_1 \cdot \frac{x_1^3}{3} + 6 \frac{x_1^4}{4} \right]_0^8 = \frac{1}{EI} \left[H_1 \cdot \frac{8^3}{3} + 6 \times \frac{8^4}{4} \right]_0^8$$

$$= \frac{1}{EI} \left(H_1 \cdot \frac{512}{3} + 6144 \right) = \frac{512}{EI} \left(\frac{H_1}{3} + 12 \right)$$

For the segment 2-3;

$$M = V_3 \cdot x_2$$

From equilibrium of the frame;

$$\sum M = 0 \text{ about (1) } \Rightarrow V_3 (6) + H_3 (8) - 12 (8)(4) = 0$$

$$V_3 = \frac{1}{6} (384 - 8H_3)$$

$$\sum H = 0 \Rightarrow H_3 = H_1 + 12 (8) = H_1 + 96$$

$$\text{So, } V_3 = \frac{1}{6} [384 - 8(H_1 + 96)] = \frac{1}{6} (-384 - 8H_1) = -64 - \frac{4}{3}H_1$$

$$M = \left(-64 - \frac{4}{3}H_1 \right) x_2$$

$$\frac{\partial M}{\partial H_1} = -\frac{4}{3}x_2$$

$$u_{2-3} = \int_0^6 \frac{M^2}{2EI} dx_2$$

$$\frac{\partial u_{2-3}}{\partial H_1} = \int_0^6 \frac{\partial M}{\partial H_1} \cdot \frac{M}{EI} dx_2 = \frac{1}{EI} \int_0^6 \left(-\frac{4}{3}x_2 \right) \left(-64 - \frac{4}{3}H_1 \right) \cdot x_2 dx_2$$

$$= \frac{1}{EI} \int_0^6 \left(\frac{256x_2^2}{3} + \frac{16x_2^2}{9}H_1 \right) dx_2 = \frac{1}{EI} \left[\frac{256x_2^3}{3(3)} + \frac{16x_2^3}{9(3)}H_1 \right]_0^6 = \frac{1}{EI} \left[\frac{256(6)^3}{3(3)} + \frac{16(6)^3}{9(3)}H_1 \right]$$

$$= \frac{384}{EI} \left[\frac{256(6)^3}{3(3)} + \frac{16(6)^3}{9(3)}H_1 \right] = \frac{384}{EI} \left(16 + \frac{H_1}{3} \right)$$

$$\frac{\partial u_{1-2}}{\partial H_1} + \frac{\partial u_{2-3}}{\partial H_1} = 0$$

$$\frac{512}{EI} \left(\frac{H_1}{3} + 12 \right) + \frac{384}{EI} \left(16 + \frac{H_1}{3} \right) = 0$$

$$\frac{4}{3} \left(\frac{H_1}{3} + 12 \right) + \left(16 + \frac{H_1}{3} \right) = 0$$

$$\frac{7}{9}H_1 + 32 = 0$$

$$H_1 = -41.14 \text{ kN (} \leftarrow \text{)}$$

$$H_3 = -41.14 + 12 (8) = 54.86 \text{ kN (} \leftarrow \text{)}$$

$$V_3 = -64 - \frac{4}{3}(-41.14) = -9.15 \text{ kN (} \downarrow \text{)}$$

$$V_1 = -V_3 = +9.15 \text{ kN (} \uparrow \text{)}$$